

UNIVERSIDAD AUTÓNOMA DE CIUDAD JUÁREZ
INSTITUTO DE INGENIERÍA Y TECNOLOGÍA
DEPARTAMENTO DE INGENIERÍA INDUSTRIAL Y DE
MANUFACTURA

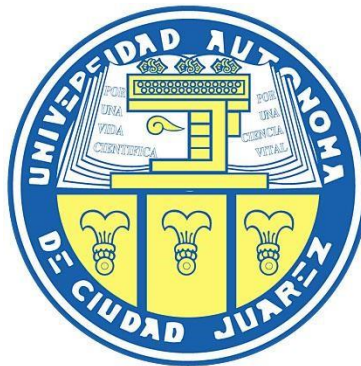

Diseño e integración de un dispositivo mecánico para un sistema palpador LVDT (transformador diferencial de variación lineal) para la medición de redondez

PROYECTO QUE PRESENTA
JOSÉ MARTÍN FÉLIX PEDREGÓN

COMO REQUISITO PARCIAL PARA OBTENER EL GRADO DE
MAESTRÍA EN INGENIERÍA EN MANUFACTURA

BECARIO CONACYT EXPEDIENTE No. 813431

ASESOR

Dr. Javier Molina Salazar

Ciudad Juárez, Chihuahua.

23 de noviembre de 2018

Dedicatoria

Este proyecto al igual que este posgrado y cada logro que he obtenido en mi vida va dedicado a mi padre el Sr. José Félix Miramontes y a mi madre la Sra. Martha Pedregón Iturralde, ya que gracias a su esfuerzo, consejos, dedicación, trabajo y sacrificio soy quien soy y he llegado hasta donde estoy.

A mi hija Giza Xenia Félix G. quien es mi mayor motivante para culminar este posgrado y por ser la inspiración para expandir mis conocimientos y continuar con este espíritu de superación.

A mi esposa la Mtra. Gizeh Gutiérrez L. por ser la autora y razón por la que me decidí a entrar a estudiar esta maestría y ser mi motor en el transcurso de esta.

A mi hermano Adrián Félix Pedregón por prestarse a ese juego de competencia y superación que llevamos desde niños, el cual nos ha permitido alcanzar nuestras metas y nos ha llevado tan lejos.

Agradecimientos

Quiero expresar mi gratitud a mi asesor el Dr. Javier Molina Salazar por brindarme la oportunidad de desarrollar este proyecto, por guiarme y asesorarme en el transcurso de este. A la empresa Kufferath Group por la oportunidad que brindaron para desarrollar el proyecto en su departamento de investigación y desarrollo, así mismo deseo agradecerle al Ing. Joel Garay Rivera por su asesoramiento y soporte en el transcurso del proyecto. A mis profesores por su dedicación, compartir sus conocimientos y por el tiempo que me otorgaron. Al Ing. Héctor Chavarría García por su disposición, ayuda y asesoramiento en el desarrollo del sistema mecánico. Por último, le agradezco a CONACyT ya que gracias a su apoyo económico me fue posible cursar y concluir este posgrado.

A todos aquellos que de alguna manera me brindaron su apoyo, tiempo, conocimiento o una razón para realizar esta maestría, muchas gracias.

ÍNDICE

1. INTRODUCCIÓN	5
1.1 Planteamiento del problema.....	8
1.2 Objetivos	8
1.3 Hipótesis.....	9
1.4 Justificación.....	10
1.5 Alcance.....	11
1.7 Cronograma de actividades	12
2. MARCO TEÓRICO.....	13
2.0 Introducción	13
2.1 Instrumentos de medición	15
2.11 Sistema de visión UACJ	30
2.12 Kufferath Group	30
3. METODOLOGÍA.....	32
4. DESARROLLO.....	37
5. RESULTADOS	59
6. BIBLIOGRAFIA	82

Capítulo 1

1. INTRODUCCIÓN

A lo largo del tiempo distintas industrias en el mercado han optado por diversos sistemas de medición de acuerdo con Rodríguez [1], dichos sistemas tienen diversas capacidades y dependiendo de la aplicación específica existe algún aparato de medición que van desde lo más simple como un flexómetro, hasta complejas máquinas capaces de obtener mediciones de formas en varios ejes al mismo tiempo como lo es la medición de redondez. La cual es una de las mediciones más importantes en la metrología de formas, ya que cualquier tipo de máquina o equipo de tipo industrial posee una serie de componentes cuya forma es redonda, en todas o algunas de sus secciones (ejes, rodamientos, engranajes, cilindros, etc.). Según Pérez [2] la cuestión importante, desde el punto de vista del movimiento a que este tipo de piezas está sometido o generando, es conocer y cuantificar la magnitud del defecto de redondez que caracteriza a dichos elementos. Esta medida puede ser un indicador de calidad del producto, del óptimo o inadecuado funcionamiento de las máquinas donde se elaboran las piezas.

La compañía Kufferath Group es una de las compañías que se dedican al negocio en la tecnología de control para las tecnologías de precisión de la industria automotriz, al igual desarrollan nuevos equipos de integración [3]. Actualmente la compañía tiene varios proyectos en los cuales es altamente competitivo sobre innovación e implementación de sistemas robustos de medición.

Kufferath Group en México posee en gran parte de su negocio la producción de los sistemas de prueba eléctrica, par de torsión, sistemas de visión, módulos de prueba, bancos de prueba eléctrica, software y desarrollo de equipos especiales bajo requerimiento de clientes sobre pruebas exclusivas del cliente final [3].

Para ello, una de las ramas que se le dificulta en cuanto a desarrollo de nuevas tecnologías, es el conocimiento sobre sistemas de medición en los cuales no se cuenta con equipos para el despliegue de información y entrenamientos debido a que estos equipos son muy exactos y precisos, utilizan componentes especiales con precios elevados; el mantenimiento general lo puede realizar el usuario, sin embargo, si este sufre algún daño tendrá que ser un técnico especializado el indicado para realizar reparaciones al equipo lo cual implica un costo, a su vez las partes no son comerciales y por lo regular tienen tiempos de entrega largos.

Para evitar esta situación la empresa Kufferath de México requiere del desarrollo de un dispositivo para conceptualizar los sistemas de medición de alta precisión para la adquisición de datos que permita la capacitación del personal sin el riesgo de daño en equipos profesionales.

Durante la realización de este proyecto se culminaron las etapas del diseño y construcción del sistema mecánico del dispositivo y el procesamiento de los datos de un sistema de medición de la circularidad de una pieza en la operación de cilindridad, tomando como base material y partes recicladas para el funcionamiento de un LVDT (transformador diferencial de variación lineal) [4] y las necesidades del proceso de medición. Este proyecto se realizó en tres etapas

principales; determinación de las características de la pieza sometida al proceso de medición de redondez, la programación del sensor LVDT basado en los requerimientos de medida de circularidad y la simulación del proceso de medición mediante un software especializado. Debido a la escasez de tiempo el desarrollo de este proyecto está limitado al diseño del sistema para medir solo la circularidad de una pieza en la operación de cilindrado y la simulación del funcionamiento del sensor de medida.

1.1 Planteamiento del problema

La empresa Kufferath de México requiere un dispositivo para conceptualizar los sistemas de medición de alta precisión para la adquisición de datos que permita la capacitación del personal sin el riesgo de daño en equipos profesionales los cuales son de alto costo tanto en refacciones como en mantenimiento.

1.2 Objetivos

Objetivo general:

Diseñar la estructura mecánica de un dispositivo que sea capaz de integrarse con una interfaz para medir la redondez de una pieza por medio de un gauge palpador LVDT (micrómetro electrónico verificador) [4] que permita la capacitación del personal de la empresa Kufferath.

Objetivos Particulares:

- Fabricar un prototipo de medición que sea capaz de medir la circularidad de piezas que tengan como dimensiones máximas una pulgada de diámetro por 2 pulgadas de altura.
- Diseñar y fabricar un dispositivo de medición de redondez que sea de bajo costo y que la manipulación, mantenimiento y reparación del sistema mecánico la puedan realizar empleados de Kufferath de México sin necesidad de un especialista o proveedor externo.
- Que el sistema sea capaz tomar lecturas circulares interpretables en diagramas polares de medición.
- Tomar las lecturas del sensor para realizar la tabla de datos y realizar su interpretación por medio de un diagrama polar.

1.3 Hipótesis

El presente proyecto propone diseñar un dispositivo (A) para medición de redondez en la operación de circularidad para la capacitación del personal de “Kufferath Group de México”, el cual debe ser de menor costo que realizar un servicio de mantenimiento al equipo Mitutoyo RA500H, También debe proporcionar una menor variación al momento de la adquisición de datos de medición con respecto a los que se obtengan mediante el uso de un sistema manual (B); lo anterior mencionado se lleva a cabo evaluando la variación de los datos obtenidos entre los métodos (A) y (B) midiendo pin gages de diferentes diámetros. Para la evaluación de la propuesta se utilizan las siguientes variables de respuesta:

H_0 = Precio igual o mayor a un servicio de mantenimiento del equipo de medición Mitutoyo RA500H.

H_1 = El dispositivo mecánico diseñado es de menor costo que la realización de un servicio de mantenimiento al equipo Mitutoyo RA500H.

$$**$H_0: \mu_{Propuesta(A)} = \mu_{RA500H}$**$$

$$**$H_1: \mu_{Propuesta(A)} < \mu_{RA500H}$**$$

Unidad de medida: \$ precio

H_0 = El dispositivo diseñado (A) tiene igual o mayor variación en la obtención de información con respecto a un sistema manual (B).

H_1 : El dispositivo diseñado (A) es capaz de proporcionar lecturas de medición de circularidad más precisas que con el sistema de medición manual (B).

$$**$H_0: \mu_{\%E(A)} = \mu_{\%E(B)}$**$$

$$**$H_1: \mu_{\%E(A)} < \mu_{\%E(B)}$**$$

Unidad de medida: % de error en la variación de las mediciones de los pin gages.

1.4 Justificación

En la Industria local actual la falta de un sistema de medición de redondez de piezas torneadas capaz de entregar información eficiente y precisa limita el aseguramiento de la calidad del proceso de las piezas manufacturadas, debido a que los instrumentos de medición convencionales, como el comparador de carátula y el vernier, micrómetro, entre otros no almacenan los datos mientras se está realizando la medición, para un análisis posterior [5].

Geng [6] plantea que si un sistema de medición que realiza de manera automatizada cálculos de medición disminuye notablemente el tiempo (eficiencia) empleado para la comprobación, los errores cometidos durante el proceso y mostrar los resultados (por medio de un software de aplicación específica) de una forma amigable y detallada.

Tomando lo anterior descrito como premisa la empresa Kufferath de México requiere el diseño de un equipo para capacitar su personal que permita conceptualizar los sistemas de medición de alta precisión para la adquisición de datos sin el riesgo de daño en equipos profesionales los cuales son de alto costo tanto en refacciones como en mantenimiento.

Los beneficios teórico-prácticos a obtener con el proyecto permiten el desarrollo de tecnologías no alcanzables por costos elevados.

1.5 Alcance

El sistema de medición será capaz de medir la circularidad en piezas cilíndricas, para posteriormente exportar los datos para su interpretación. Además, se prevé que la estructura mecánica servirá como base para futuras investigaciones que planteen realizar las operaciones de rectitud, planicidad y cilindridad.

1.6 Delimitaciones

El sistema de medición del dispositivo trabajará bajo las siguientes especificaciones:

1. La dimensión máxima en el eje Z que podrá ser medida es de 2 pulgadas.
2. La dimensión máxima diametral que permite el Chuck es de 1 pulgada.
3. Angulo máximo de sistema rotatorio del palpador LVDT es de 360 grados en X y 190 en Z.
4. debido a los altos costos en los materiales y componentes, se reciclo y retrabajo cada parte por lo que la precisión y la estética son deficientes.

1.7 Cronograma de actividades

El desarrollo del proyecto se dividió en 14 semanas tal y como muestra la figura 0.



Figura 0. Cronograma de actividades agosto-noviembre 2018.

Capítulo 2

2. MARCO TEÓRICO

2.0 Introducción

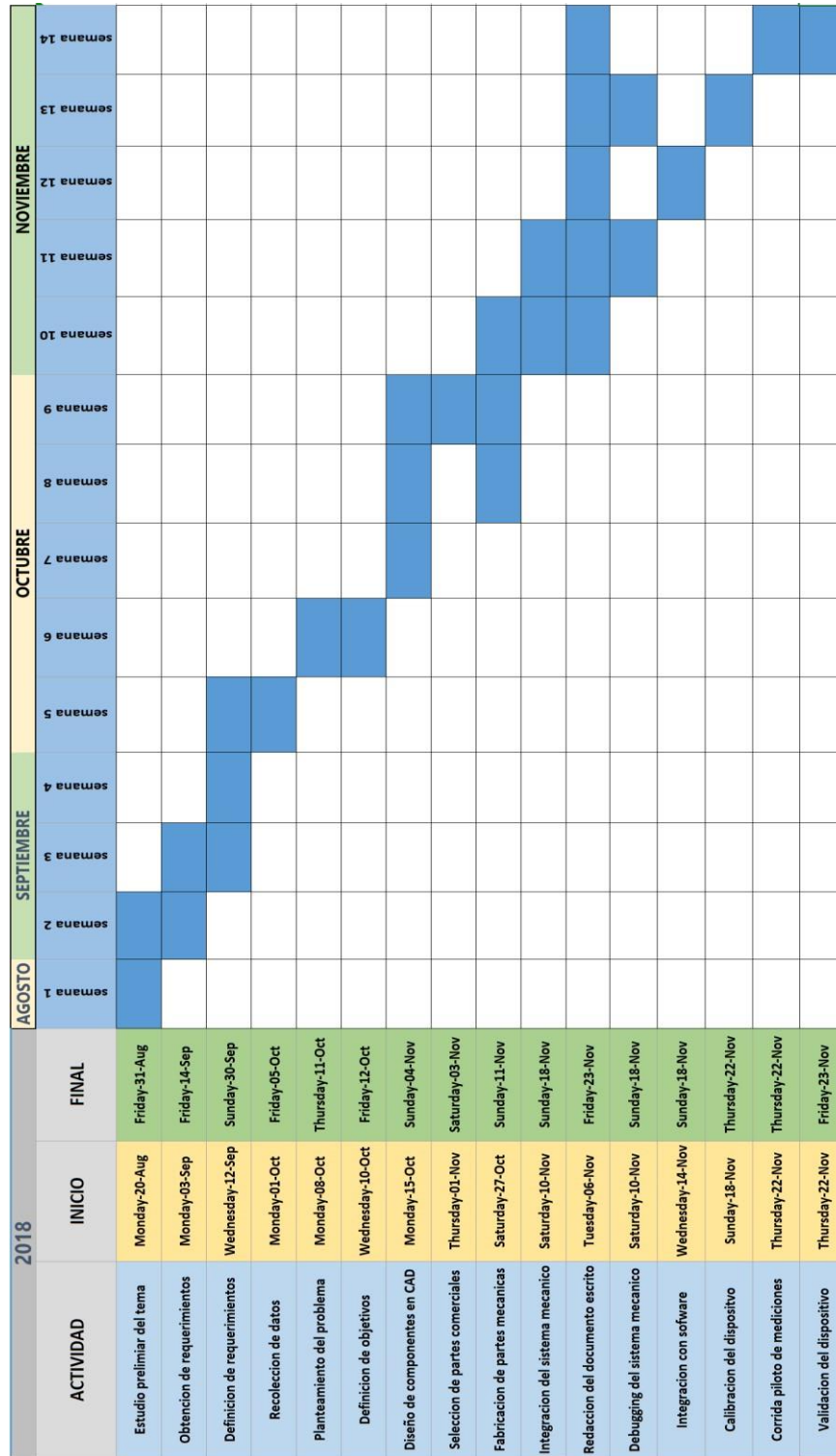
Desde el inicio de los tiempos la humanidad ha empleado unidades antropométricas para describir una determinada dimensión, de modo que pies, codos, palmos o dedos han sido utilizados, prácticamente hasta el siglo XIX, como patrones comunes de medida [7]. En la tabla 1 se observa un diagrama histográfico de los instrumentos de medición.

Tabla 1. Evolución de los instrumentos de medición.

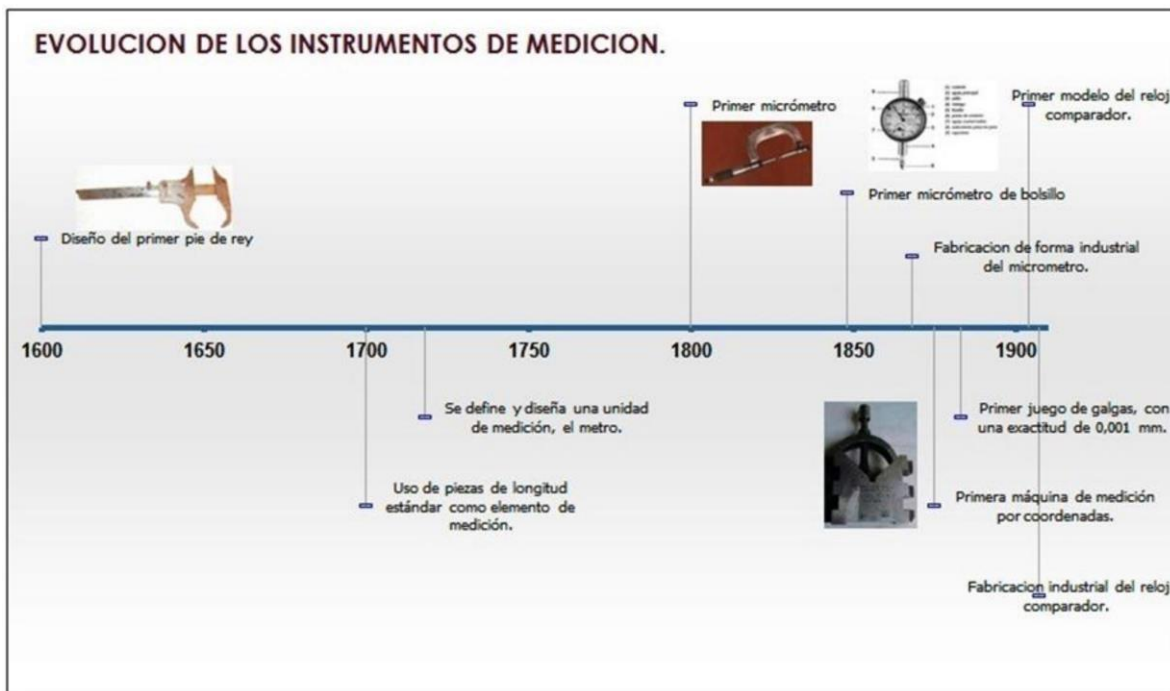

Una de las formas fundamentales más importantes para los componentes de la ingeniería de procesos de manufactura es el perfil redondo o circular. Las formas circulares surgen en muchas aplicaciones, sobre todo en las superficies de apoyo, tales como ejes de rotación y rodamientos como en baleros [4].

La tolerancia de redondez es primordial y debe estar mucho más cerca (por lo general cinco veces) que el del margen de otros perfiles [4]. Por ejemplo, un rodamiento de rotación cuyos componentes no son exactamente redondos tienden a ser ruidosos y es probable que falle prematuramente, es por lo anterior, que la medición de la redondez debe ser lo más exacta posible para asegurar el adecuado funcionamiento de las partes. Las estructuras redondas son las encargadas, en los procesos industriales de rotación, de transmitir o generar la mayoría de las oportunidades, energía, lo que lleva un desgaste de la pieza, que debe ser reemplazada por una nueva, con las medidas correctas para que pueda generar un movimiento libre y con la menor fricción posible para evitar un consumo innecesario de energía ya sea eléctrica o mecánica durante el desarrollo de las acciones productivas [5].

A diferencia de la medición de la longitud, anchura y altura, la medición de redondez requiere un conocimiento mucho más profundo de las dimensiones, características y sus relaciones con los instrumentos de medición en las tres dimensiones [1]. Por la competitividad actual del mercado de piezas redondas, los productores deben cumplir con normas que establecen unos límites de tolerancia; entre más pequeños sean, la pieza va a tener un mejor estándar de calidad, lo que la hace más apta para las exigencias del consumidor cuando se necesite realizar intercambiabilidad de piezas [6].

2.1 Instrumentos de medición.

Son aquellos que aportan las dimensiones de alguna magnitud importante, como los que permiten estimar distancias recorridas en un tramo determinado y su velocidad, y los que se usan para medir desplazamientos tan pequeños, que no son visibles a simple vista, como lo son los defectos superficiales en una pieza mecánica [8]. Un ejemplo muy claro es el comparador de carátula en el cual un pequeño movimiento del husillo se amplifica mediante un tren de engranes que mueven en forma angular una aguja indicadora sobre la carátula del dispositivo, donde dicha aguja indicadora puede dar tantas vueltas como lo permita el mecanismo de medición del aparato. Existen en el mercado una gran variedad de soportes y accesorios para diferentes comparaciones. En la figura 1 se observa el comparador de carátula y su respectivo soporte para la medición de las tolerancias dimensionales de una pieza mecanizada.



Figura 1. Comparador de carátula

2.2 Forma de medir la redondez.

La característica circular es uno de los elementos geométricos más básicos de las partes mecánicas [9]. De acuerdo con Gadelmawla [10] en entornos de fabricación, pueden producirse variaciones en las características circulares debido a la rotación imperfecta, la acción de corte errática, la lubricación inadecuada, el desgaste de la herramienta, las piezas defectuosas de la máquina, la vibración, la desalineación de las mordazas del mandril, etc. Li & Shi [9] argumentan que si el error de redondez se puede evaluar con precisión y que este influirá directamente en el rendimiento y la vida útil de los productos mecánicos. Por lo tanto, existe el requisito de desarrollar un método de inspección automática que satisfaga las necesidades de la inspección de redondez.

El estándar de tolerancia y dimensionamiento ANSI Y14.5 [11] define las tolerancias de forma de un componente con referencia a una característica geométrica ideal. Según Mu-Chen et al. [12] ya varios investigadores han desarrollado métodos para establecer la característica de referencia y evaluar el error de circularidad. Existen varias técnicas de medición de geometría disponibles para estimar la característica de referencia (círculo). En la figura 2, se aprecia que, para la medición de la redondez, cualquier línea circunferencial debe estar contenida dentro de la zona de tolerancia formada entre dos círculos coplanares con una diferencia en radio de t .



Figura 2. Medición de la redondez.

2.3 Instrumentos medidores de redondez.

Para medir la redondez es necesario realizar una rotación, bien sea de la pieza o del palpador mediante el uso de un sensor que detecta la variación de pequeñas deformaciones. La determinación de la redondez se realiza entonces a partir de la evaluación de irregularidades características (ondulaciones y distancias pico-valle) y surgen en la pieza o patrón como consecuencia de las operaciones de mecanizado [9]. Los instrumentos medidores de redondez son de dos tipos básicos, (ver figura 3); de mesa giratoria, en los que gira la pieza, mientras el palpador permanece estacionario en contacto con ella, y de palpador giratorio, en el cual la pieza permanece estacionaria, mientras el palpador gira en torno a ella, contactándola en su superficie.

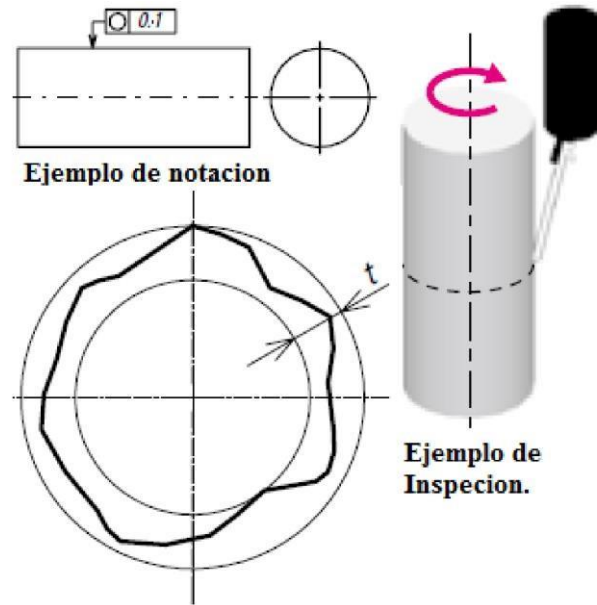

Figura 3. Formas de medición de redondez: con mesa giratoria o con palpador giratorio.

Para el desarrollo de este proyecto se va a emplear la medición de redondez de pieza o mesa giratoria, este método se seleccionó por la facilidad que presenta al momento de realizar la evaluación de la circularidad de una pieza, ya que el LVDT estaría fijo evitando así el movimiento de los cables ligados a este (alimentación. salida al computador).

2.4 Ajuste antes de la medición de redondez.

En la figura 4 se observa una compensación del desplazamiento (excentricidad), entre el eje de la mesa giratoria de la prueba de redondez y el de la pieza de trabajo que produce como resultado una distorsión de la forma de medición y en consecuencia produce un error en el cálculo del valor de redondez. Cuanto mayor es la excentricidad, mayor es el error en la redondez calculada [9]. Por lo tanto, la pieza de trabajo debe estar centrado (ejes coincidentes) antes de la medición.

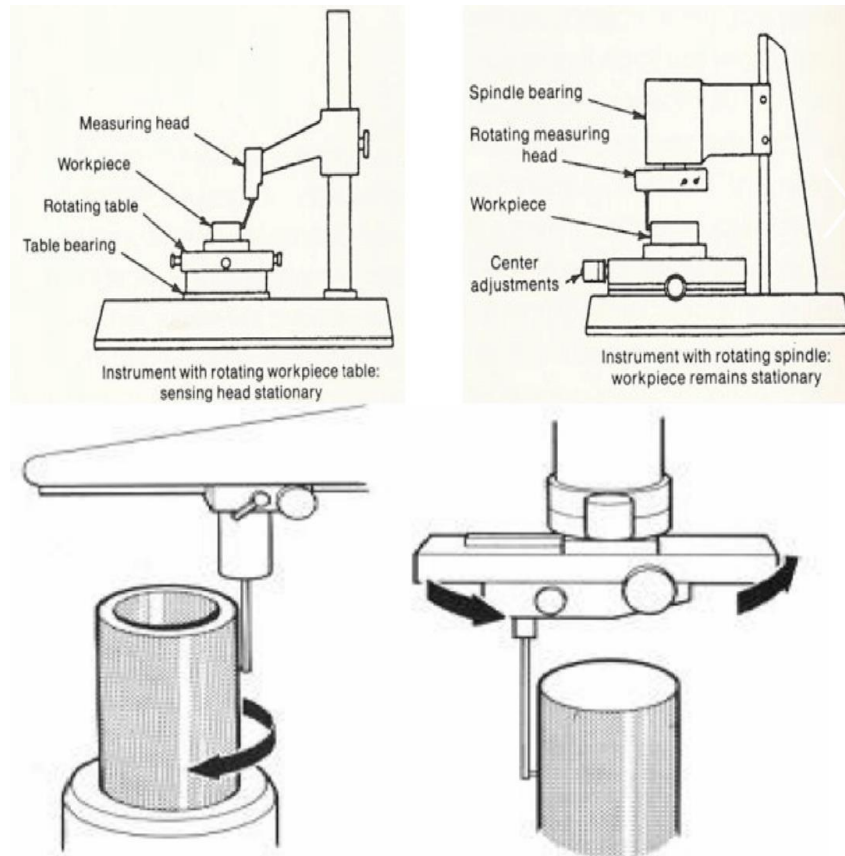
Algunos verificadores de la redondez apoyan la medida exacta con una corrección en la función del error de limitación. La eficacia de esta función se puede ver en el gráfico siguiente.



Figura 4. Efecto de la función de compensación de excentricidad.

2.5 Efecto de la configuración del filtro en el perfil medido.

En la figura 5 se observa que los valores de redondez medida se ven muy afectados por la variación del valor de corte del filtro. Es necesario configurar el filtro adecuado para la evaluación requerida.

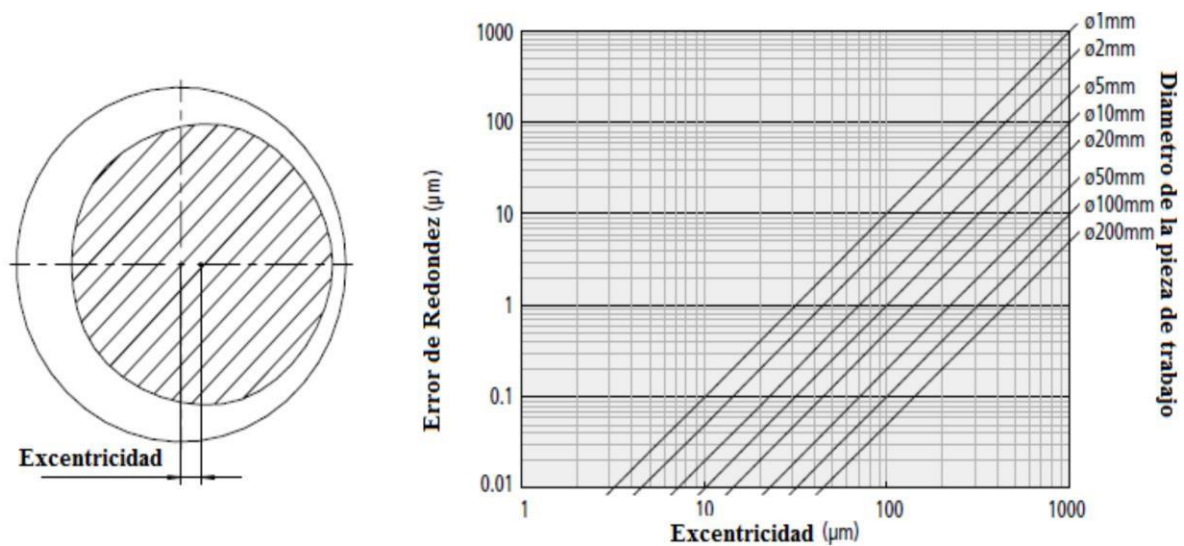

Figura 5. Efecto de la configuración del filtro en el perfil.

Cualquier inclinación del eje de un objeto con respecto al eje rotatorio del instrumento de medida causará un error elíptico (Ver figura 6). La nivelación debe ser realizada de modo que estos ejes sean suficientemente paralelos [2].

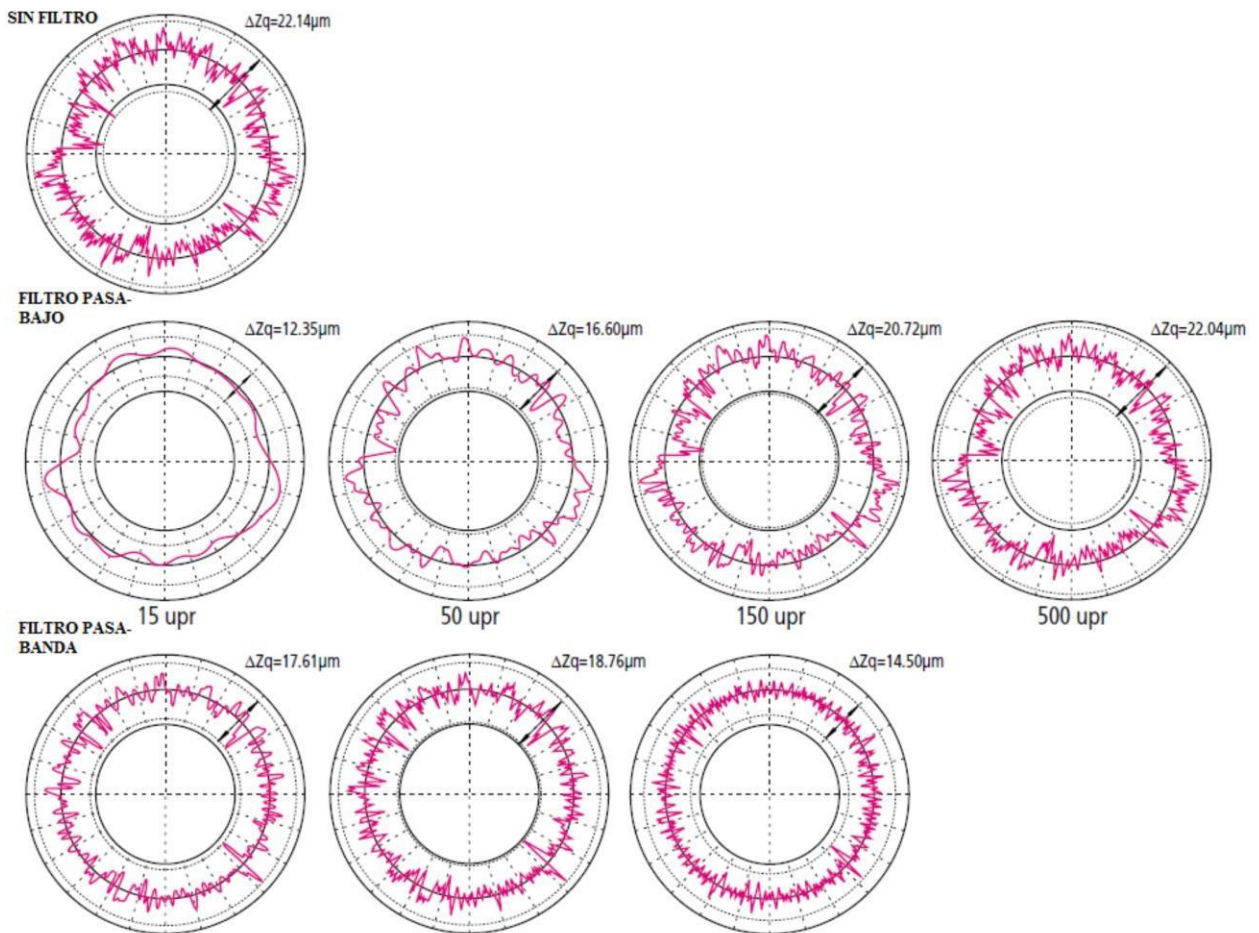

Figura 6. Inclínación contra error elíptico

2.6 Evaluación de redondez perfil medido.

Los medidores de redondez usan los datos de medición para generar círculos de referencia, cuyas dimensiones definen el valor de redondez. De acuerdo con Wentao & Dan [13] existen cuatro métodos para generar estos círculos, como es ilustrado en la tabla 2; y cada método tiene características individuales, así que, el método escogido es el que mejor se acopla a la funcionalidad de la pieza.

Tabla 2. Evaluación de redondez perfil medido.

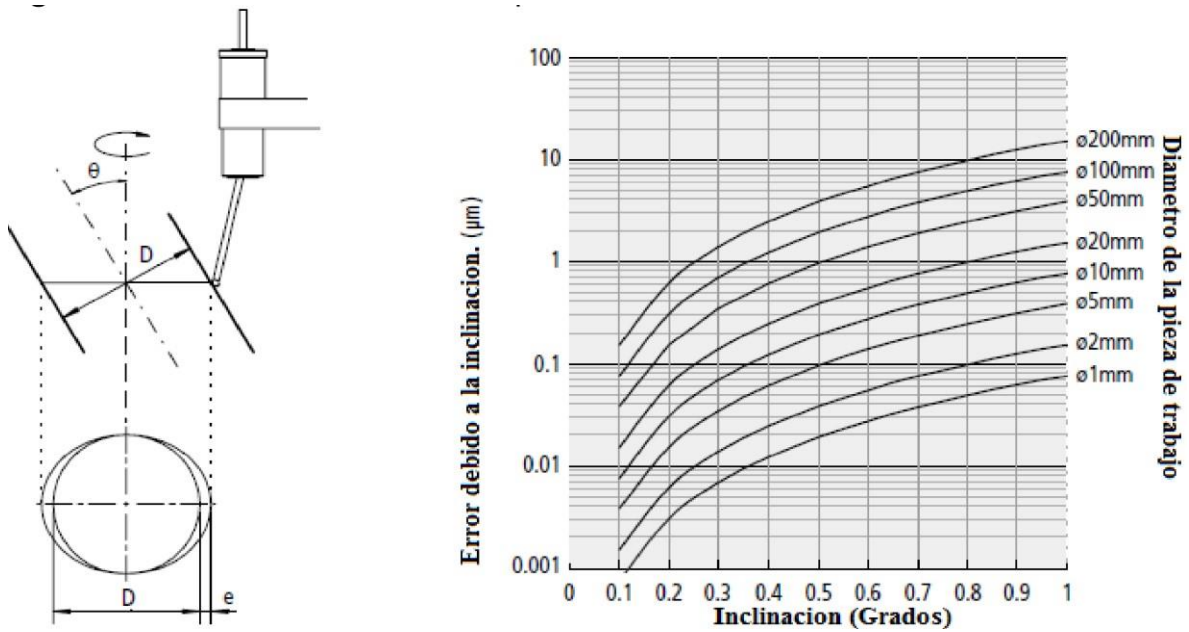
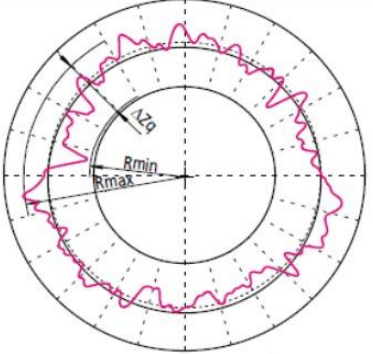
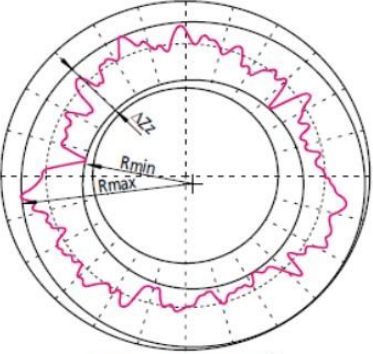
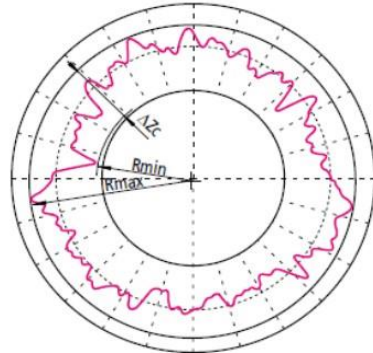
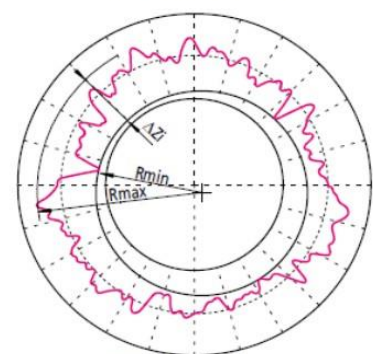
METODO.	GRAFICA.	CARACTERISTICAS.
<p>Círculo de mínimos cuadrados (LSC: Least Square Circle)</p>	 <p style="text-align: center;">$\Delta Zq = Rmax - Rmin$</p>	<p>Un círculo es ajustado al perfil medido, de modo que la suma de los cuadrados de los alejamientos de los datos del perfil desde este círculo es un mínimo. El valor de redondez es entonces definido, como la diferencia entre los máximos alejamientos del perfil desde este círculo (pico más alto a valle más bajo).</p>
<p>Círculo de zona mínima (MZC: Minimum Zone Circles)</p>	 <p style="text-align: center;">$\Delta Zz = Rmax - Rmin$</p>	<p>Dos círculos concéntricos son posicionados para encerrar el perfil medido tal que su diferencia radial es un mínimo. El valor de redondez es entonces definido como la separación radial de estos dos círculos</p>
<p>Mínimo círculo circunscrito (MCC: Minimum Circumscribed Circle)</p>	 <p style="text-align: center;">$\Delta Zc = Rmax - Rmin$</p>	<p>El círculo más pequeño que puede encerrar el perfil medido es creado. El valor de redondez es entonces definido como el máximo alejamiento del perfil desde este círculo. Este círculo es referido algunas veces como el círculo del anillo patrón.</p>
<p>Máximo círculo inscrito (MIC: Maximum inscribed Circle)</p>	 <p style="text-align: center;">$\Delta Zi = Rmax - Rmin$</p>	<p>El mayor círculo que puede ser encerrado por los datos del perfil es creado. El valor de redondez es entonces definido como el máximo alejamiento del perfil desde este círculo. Este círculo es referido algunas veces como el círculo del perno patrón.</p>

2.7 Principio de operación de un LVDT.

El LVDT es un transductor electromecánico, que produce una salida eléctrica proporcional al desplazamiento del núcleo móvil separado [4]. La figura 7. muestra el diagrama físico de un LVDT, donde se observa que cuenta con tres bobinas equidistantes sobre un cuerpo cilíndrico. Hay un núcleo magnético en forma de varilla que está ubicado en forma axial dentro del ensamble de las bobinas y proporciona una trayectoria para enlazar las bobinas mediante el flujo de magnetización. Al excitar la bobina central o primaria con una fuente de corriente alterna, se inducen voltajes en las dos bobinas externas (secundarios) [14].

En la configuración del transformador LVDT, las bobinas externas o secundarias se conectan en serie y opuestas, de tal forma que los dos voltajes inducidos tengan fases contrarias.



Figura 7. Transformador Diferencial De Variación Lineal (LVDT).

La salida del LVDT es proporcional al desplazamiento, la salida consiste en la diferencia de tensión entre los secundarios del sensor [14].

$$v_o = k (v_1 - v_2) \quad (1)$$

$$v_o = |k_f x| \quad (2)$$

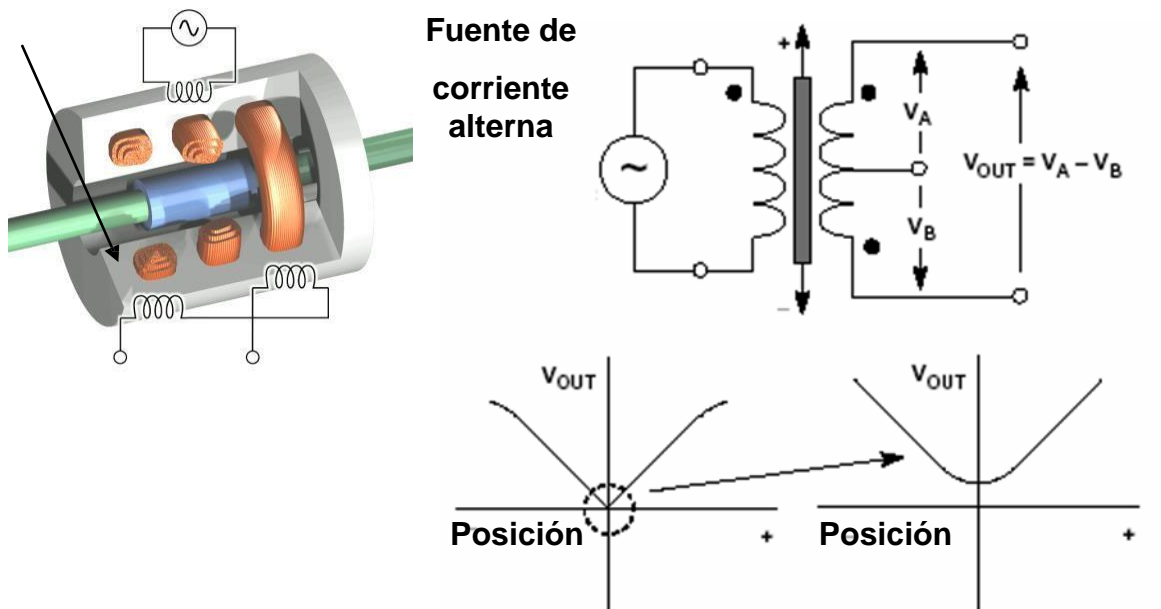
El voltaje de salida v_o (ecuación 2) es un voltaje efectivo (RMS), esto quiere decir que no es posible determinar la dirección del desplazamiento con respecto a la posición cero, en la cual el voltaje de salida no es exactamente cero. Por esta razón es necesario el acondicionamiento de señal. Una de las técnicas más utilizadas es sustraer los valores absolutos de los dos voltajes de salida [9].

Usando esta técnica, pueden medirse ambas variaciones positivas y negativas relativas al desplazamiento del núcleo. Mientras un rectificador tipo diodo/capacitor puede usarse (ver figura 8) como un circuito de valor absoluto, el rectificador de precisión mostrado en la figura 9 es más exacto y lineal. La entrada se aplica a un conversor de Voltaje/corriente que a su vez maneja un multiplicador analógico. La señal de entrada diferencial es detectada por el comparador el cual cambia el signo de la señal (en el caso negativo) del multiplicador analógico [9].



Figura 8. Acondicionamiento de señal para mejorar la salida.



Figura 9. Circuito de valor absoluto de precisión (rectificador de onda completa)

Las variables principales para medir son las irregularidades superficiales las que se definen como: cualquier elevación o depresión encontrada en una superficie a partir de la línea media; la amplitud de cada una de las irregularidades está dada por el valor absoluto de su altura o profundidad [2].

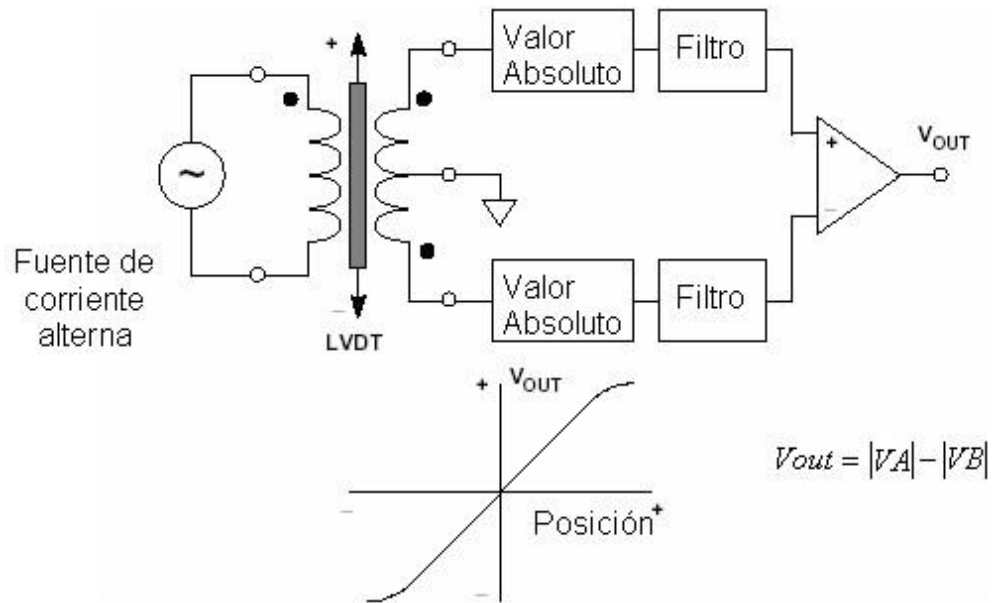
2.8 Software de simulación del sistema para medir la circularidad de piezas

Para realizar la simulación de este sistema se va a emplear un software especializado en la interpretación de datos de forma gráfica en este caso LabVIEW [15].

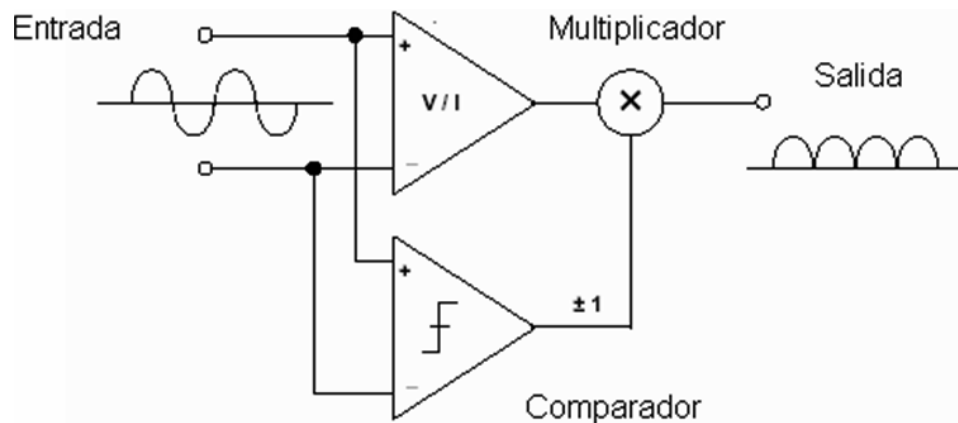
2.9 Sistema de Adquisición de datos.

El software de herramientas de adquisición de datos, junto con el entorno de LabVIEW, proporciona la capacidad de medir y analizar los fenómenos físicos. El propósito de cualquier sistema de adquisición de datos es proporcionar las herramientas y recursos necesarios para realizar este proceso matemático. Se puede considerar un sistema de adquisición de datos como un conjunto de software y hardware que se conectan con el mundo físico [15]. Un sistema de adquisición de datos típico consta de estos componentes.

- Hardware de adquisición de datos. En el interior de cualquier sistema de adquisición de datos está el hardware de adquisición de datos. La función principal de este hardware es la de convertir las señales analógicas en señales digitales, y convertir las señales digitales a señales análogas [16].
- Sensores y actuadores (transductores). Sensores y actuadores pueden ser transductores. Un transductor es un dispositivo que convierte una forma de energía de entrada en otra de salida diferente [17]. Por ejemplo, un micrófono es un sensor que convierte la energía de sonido (en forma de presión) en energía eléctrica,

mientras un altavoz es un actuador que convierte la energía eléctrica en energía de sonido.

- Hardware de acondicionamiento de señal. Las señales del sensor son a menudo incompatibles con hardware de adquisición de datos. Para superar esta incompatibilidad, la señal debe estar condicionada. Por ejemplo, puede que deba condicionar una señal de entrada amplificando o quitando componentes de frecuencia no deseados. Las señales de salida podrían necesitar el acondicionamiento también [16].
- Ordenador. El ordenador proporciona un procesador, un reloj de sistema, un autobús para transferir datos, y espacio de memoria y espacio de disco para almacenar datos [18].
- Software. El software de adquisición de datos permite que se intercambien la información entre el ordenador y el hardware. Por ejemplo, un software típico permite que configure la velocidad de muestreo de su tabla, y adquiera una cantidad predefinida de datos [19].

2.10 Sistemas de Medición de Redondez

Existen sistemas profesionales de medición de redondez los cuales son muy precisos, pero también muy delicados, a continuación, se describe uno de los más relevantes debido a sus capacidades y que en el mercado de los existentes su precio es menor a los demás.

2.10.1 LaborSM Metrological Laboratory

SM s.r.l. Fue fundada en 1984 y es una de las empresas líderes en Italia en la producción de instrumentos de medición electrónicos para la industria, centrada en la innovación y el futuro [20].

La empresa esta especializada en el diseño y producción de instrumentos altamente tecnológicos, fabrica dentro de su planta una amplia gama de instrumentos para la caracterización de superficies, errores dimensionales y para la garantía de calidad: probadores de rugosidad, probadores de redondez, perfilómetros, adquisición de datos y dispositivos de elaboración.



Figura 10: Probador de redondez R100 marca SM.

Un departamento de I + D equipado con sistemas electrónicos y micro-mecánicos de última generación ayuda a SM, también en colaboración con Universidades, a diseñar y desarrollar productos tecnológicamente avanzados [20].

2.10.2 Probador de Redondez Todo en Uno R100

R100, basado en una lógica "todo en uno", es inmediatamente operativo con sólo unas pocas operaciones, y permite caracterizar todas las geometrías circulares, también complejas, presentes en una pieza [21].



Figura 11: Sistema R100 tomando medición de circularidad.

Para superficies complejas donde hay huecos, Circom es capaz de eliminarlos automáticamente o el operador puede intervenir manualmente, eliminando secciones de perfil inconsistentes. Existen múltiples accesorios para la facilitación de medición de cada característica.

ACCESSORIES			
EXPANSION PLATFORM Code: 4.400		6 JAW AUTO-CENTERING CHUCK Code: 4.406	
Allows to expand the table to a diameter of 250 mm when there are very big pieces to be measured.		Fittable directly on the table, external grip diameter 1-35mm, internal grip diameter 25-95mm.	
		3 JAW AUTO-CENTERING CHUCK Code: 4.408	
		Fittable directly on the table, internal/external reversible jaws, external grip diameter 1-32mm, internal grip diameter 18-80mm.	
		CALIBRATION SAMPLE CUTZTO Code: 6.201	
			Allows the calibration and verification of pickup and electronic board sensitivity, 17 µm nominal step.
ROUNDNESS SAMPLE Code: 6.200		SAMPLE CYLINDER Code: 6.203	
Sample hemisphere made of optical glass, typical error <math><0.05 \mu\text{m}</math>, allows control of the table oscillation.		High precision steel cylinder, allows the alignment and verification of parallelism and straightness of the Z axis. Diameter 80 mm, height 300 mm, typical deviation 1 µm.	
		EXTENSION TERMINALS	
		Extension terminals can be easily interchanged thanks to their threaded coupling. <ul style="list-style-type: none"> • Terminal L= 32 mm Code 4.300 • Terminal L= 77 mm Code 4.301 • Terminal L= 112 mm Code 4.302 • T like Terminal L= 72 mm Code 4.303 	

Figura 12: Accesorios para el R100.

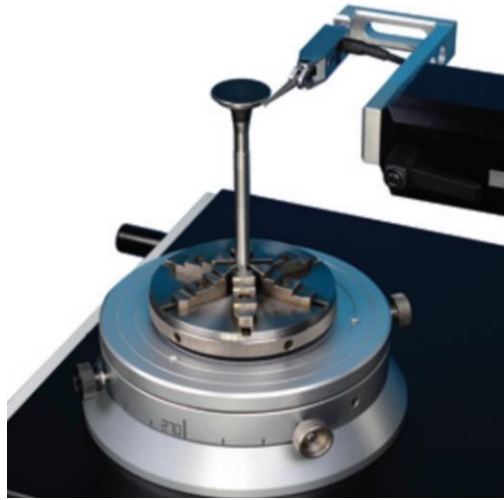
El sistema R100 es uno de los más completos de su segmento, debido a que es hasta cierto punto portátil. El dispositivo se adapta al software de Circom que fue concebido para ser extremadamente fácil de usar y fácil de usar, lo que permite capacitar a un operador en un corto período de tiempo, reduciendo los costos de capacitación y pruebas [21].

El software permite el análisis de las siguientes tolerancias geométricas: redondez, linealidad, cilindridad, conicidad, forma cónica, concentricidad, paralelismo, coaxialidad, agotamiento, agotamiento total, variación de espesor.

2.11 Sistema de visión UACJ

En el presente proyecto se usan en gran parte los componentes de un sistema de visión [1] no funcional desarrollado por ex alumnos de la UACJ, esto debido a que se deben reducir los costos en materia prima para entregar un dispositivo de bajo costo.

2.12 Kufferath Group

La compañía Kufferath Group es una de las compañías que se dedican al negocio en la tecnología de control para las tecnologías de precisión de la industria automotriz, al igual desarrollan nuevos equipos de integración. Actualmente la compañía se encuentra en 17 países por el gran impacto en innovación en diferentes ramas de la industria.

Actualmente la compañía tiene varios proyectos en los cuales es altamente competitivo sobre innovación e implementación de sistemas robustos de medición y prueba de alto y bajo voltaje en la industria automotriz en la rama de arneses y

circuitos electrónicos debido a los múltiples cambios que se han ido desarrollando en las diferentes compañías automotrices por la variante de los modelos de vehículos en el mundo.

2.12.1 Kufferath de México

Kufferath Group en México posee en gran parte de su negocio la producción de los sistemas de prueba eléctrica, par de torsión, sistemas de visión, módulos de prueba, bancos de prueba eléctrica, software y desarrollo de equipos especiales bajo requerimiento de clientes sobre pruebas exclusivas del cliente final [3].



Figura 13. Línea de prueba eléctrica en Kufferath de México.

Para ello, una de las ramas que se le dificulta en cuanto a desarrollo de nuevas tecnologías, es el conocimiento sobre sistemas de medición en los cuales no se cuenta con equipos para el despliegue de información y entrenamientos debido a los altos costos que implica la reparación de algún equipo si este se utiliza de modo didáctico o para manipulación sin experiencia por el riesgo que conlleva.

Capítulo 3

3. METODOLOGÍA

Este proyecto se lleva a cabo por medio de una investigación de tipo aplicada, dentro del contexto de los sistemas de medición por palpación, la ejecución del proyecto se realizará en cuatro etapas. Primero se determinan las características de las piezas que están sometidas al proceso de medición, segundo se diseña e integra el dispositivo mecánico que mueve el sensor palpador LVDT basado en los requerimientos de medida y del acondicionamiento de señal del sensor fundamentado en técnicas actuales, tercero se simula el proceso de medición mediante un software especializado y finalmente se valida el sistema, realizando el mismo tipo y cantidad de mediciones que con otro sistema de medición.

3.0 Situación actual

La empresa Kufferath de México requiere equipo para conceptualizar los sistemas de medición de alta precisión para la adquisición de datos sin el riesgo de daño en equipos profesionales los cuales son de alto costo tanto en refacciones como en mantenimiento. Debido a lo anterior se desarrolla un equipo de medición de redondez de bajo costo y fácil mantenimiento que permita la capacitación del personal.

Para dar seguimiento al desarrollo del proyecto se seguirá la metodología que a continuación se describe:



Figura 14: Diagrama de metodología general.

La Figura 14. muestra en forma general la metodología del proyecto la cual consta del diseño mecánico, la integración del sistema físico, verificación del sistema físico,

integración del sistema físico con el software de simulación de medición y por último la validación del dispositivo.

3.1 Diseño del prototipo mecánico

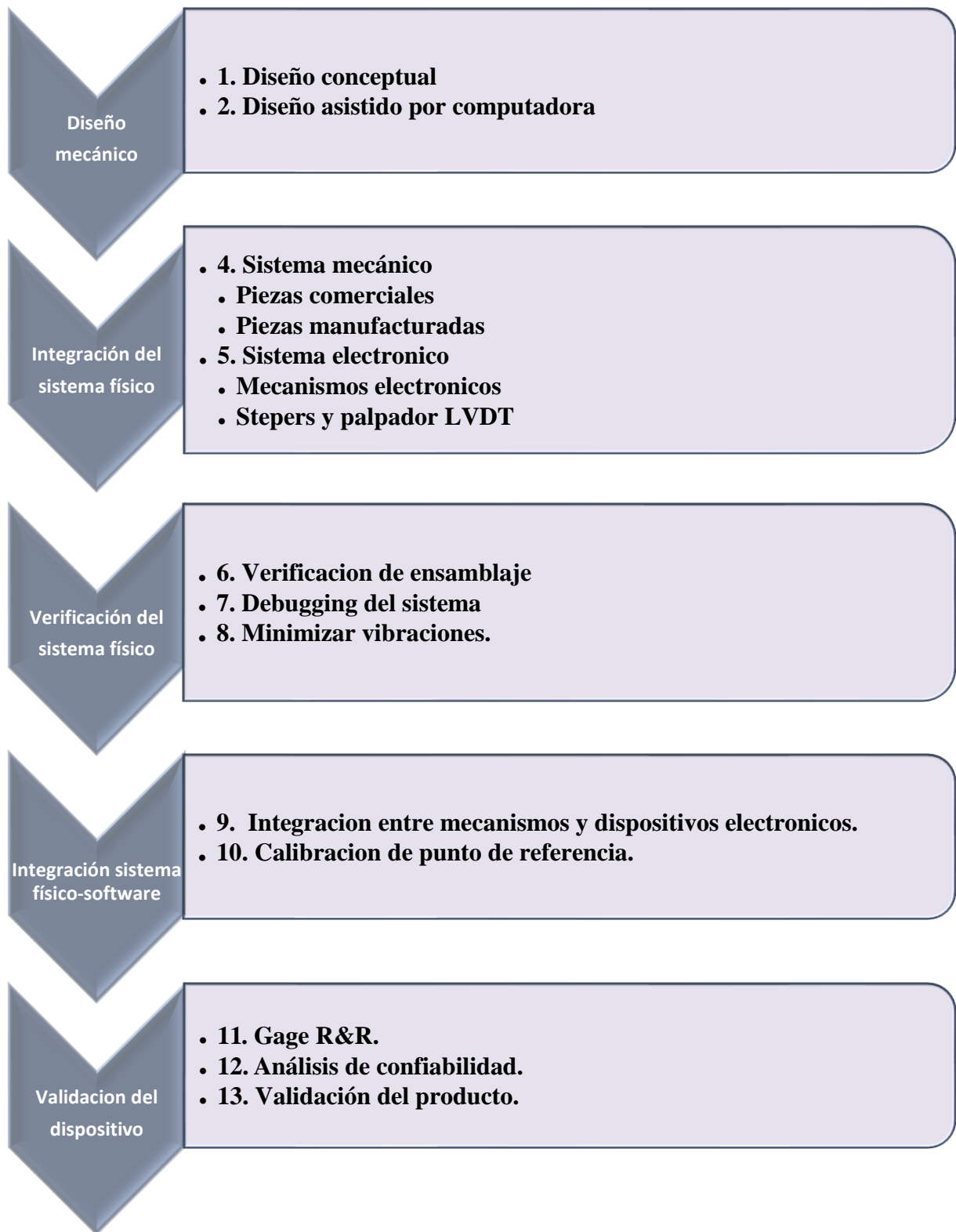
En el presente proyecto se usan en gran parte los componentes de un sistema de visión no funcional desarrollado por ex alumnos de la UACJ, esto debido a que se debe entregar un dispositivo de bajo costo. Tomando lo anterior en cuenta, se realiza el diseño morfológico respecto al reciclado de las piezas y componentes que se rescataron del sistema de visión de la UACJ.



Figura 15: Diagrama del diseño mecánico.

3.2 Integración del sistema físico

La integración del sistema físico comprende el ensamblado de las piezas manufacturadas, las comerciales y los mecanismos electrónicos (stepers y palpador) figura 16.

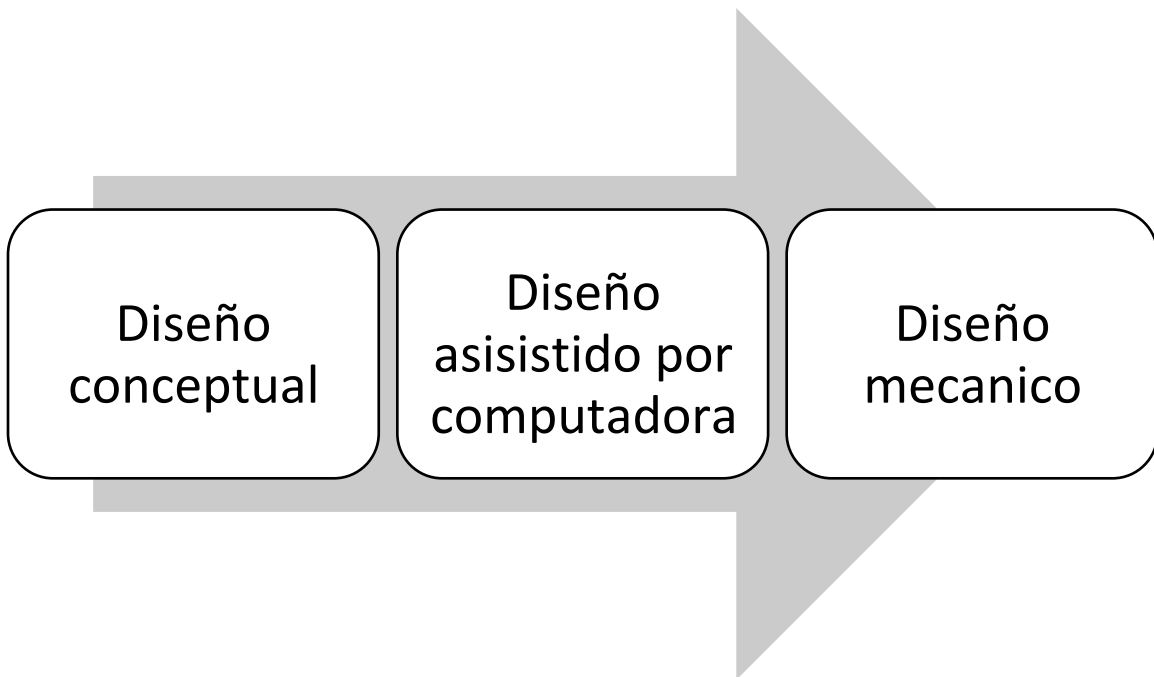

Figura 16: Diagrama de integración de sistema físico.

3.3. Verificación de sistema físico

La verificación del sistema físico comprende la revisión del funcionamiento del sistema físico con el sistema de mecanismos electrónico, es decir comprobar que el sistema se comporte de acuerdo con lo esperado por los requerimientos que se plantearon en el diseño, figura 17.

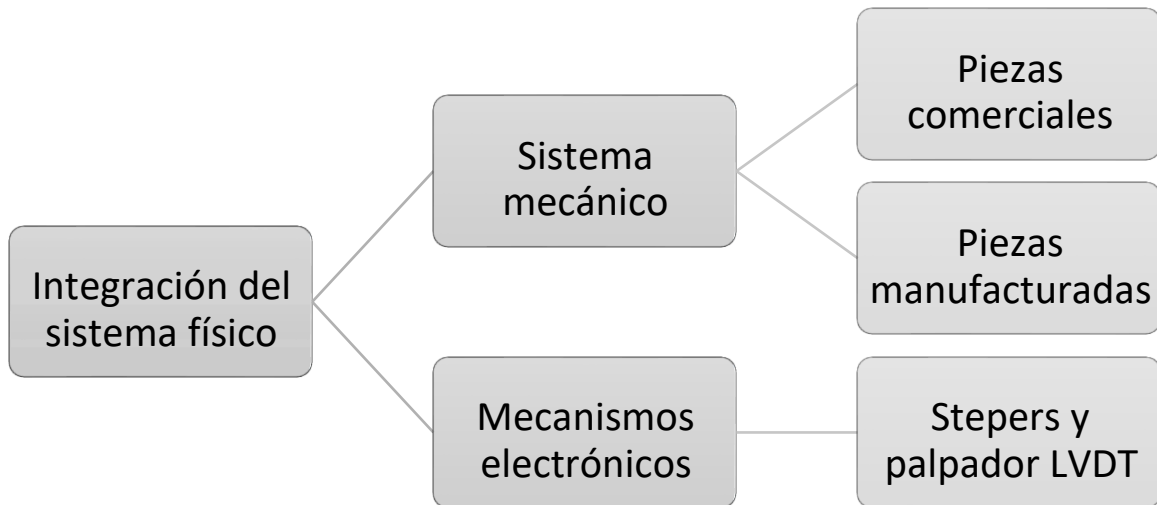

Figura 17: Diagrama de verificación del sistema físico.

Capítulo 4

4. DESARROLLO

En este capítulo se explicará de forma detallada el desarrollo del proyecto, los pasos que se siguieron tomando como base la metodología propuesta.

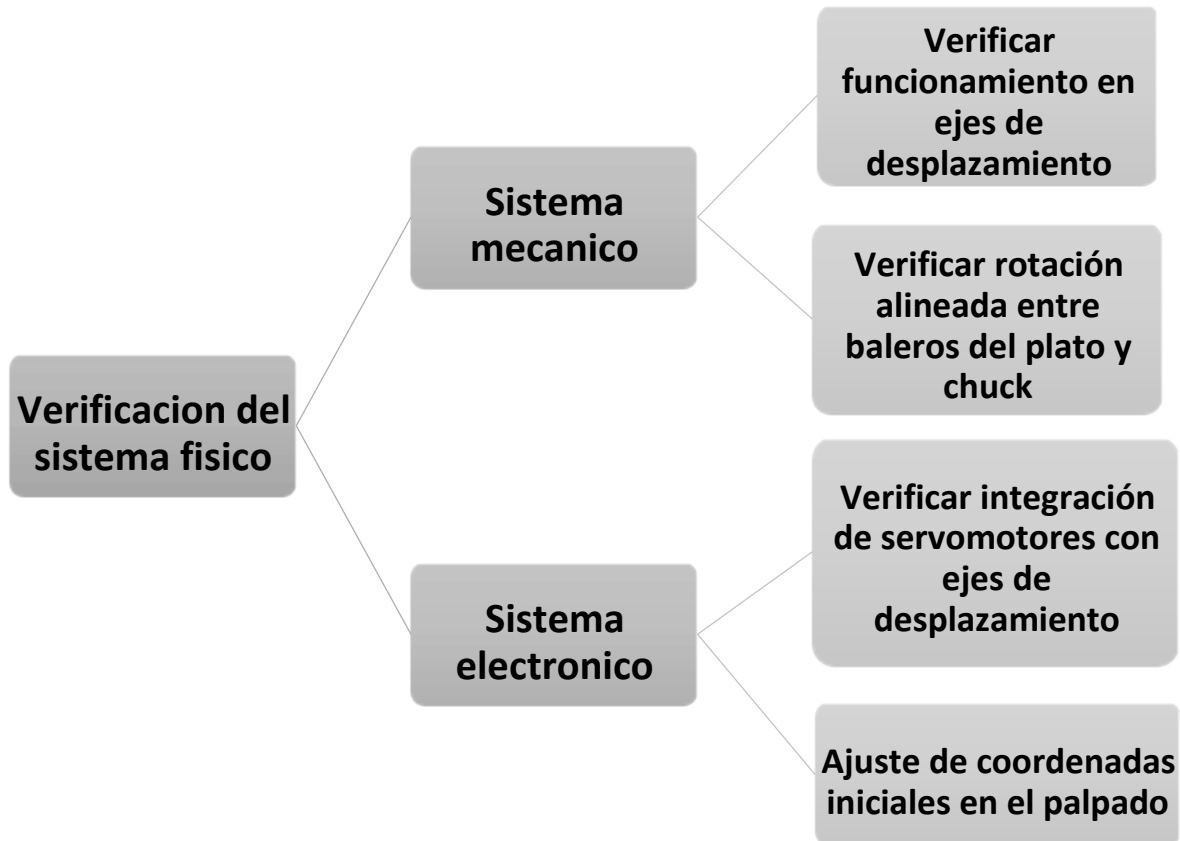
4.1 Diseño mecánico

4.1.1 Desarrollo del concepto

Teniendo en cuenta las observaciones hechas del prototipo inicial y los principales problemas identificados, se realiza una hoja de verificación, para tomar en cuenta todos los puntos relevantes en cuanto al diseño se refiere.

Tabla 3. Hoja de verificación para factores en el diseño.

FACTORES IMPORTANTES	SE CUMPLE	NO SE CUMPLE
Sistema de avance (Varillas)	X	
Alineación	X	
Dimensiones críticas (Holguras)	X	
Materiales	X	
Fricción	X	
Deslizamiento (Guías)	X	
Superficies	X	
Método de fabricación (Maquinado)	X	
Arquitectura	X	

4.1.2 Selección del sistema de deslizamiento

Hay diversos sistemas y componentes existentes en el mercado que en un solo mecanismo de guía-riel ofrecen una solución para aplicaciones donde se presentan estos problemas, algunos de los más conocidos y accesibles son los sistemas

Thomson y los THK; la ventaja de estos radica en la capacidad de entregar un movimiento sin holgura dadas las tolerancias y ajustes entre ellos (del orden de .0005 in), Así mismo el deslizamiento que estos generan, siempre y cuando la aplicación y la instalación sea la correcta es de un movimiento fluido y suave y la fricción es ampliamente reducida. A continuación, se utiliza un análisis FODA para evaluarlos y de esta manera determinar qué sistema cumple mejor con nuestras expectativas.

Tabla 4. Aspectos de sistema Thomson.

SISTEMAS DE LA MARCA THOMSON	
FORTALEZAS	<ul style="list-style-type: none"> • Permiten mayor desalineación • Costo relativamente bajo • Tolerancias de planicidad en las superficies montaje de hasta 150µm (No necesita superficies rectificadas)
OPORTUNIDADES	<ul style="list-style-type: none"> • Poseen un sistema de auto alineación que absorben tolerancias de hasta ½ grado. • Permiten una diferencia de alturas entre 2 ejes de hasta 2mm si están a una distancia de 300mm o mas retirados • Coeficientes de fricción de .001 a .004
DEBILIDADES	<ul style="list-style-type: none"> • Vida útil relativamente reducida • Generan mucho ruido • La precisión se pierde con el desgaste de la guía.
AMENAZAS	<ul style="list-style-type: none"> • El desempeño merma a altas velocidades

Tabla 5. Aspectos del sistema THK.

SISTEMAS DE LA MARCA THK	
FORTALEZAS	<ul style="list-style-type: none"> • Soportan cargas por el rango de los 20Kn • Necesitan poco mantenimiento • Generan poco ruido
OPORTUNIDADES	<ul style="list-style-type: none"> • Rango de precarga de 3% a 13% bajo cargas dinámicas • Se puede usar un solo riel para solucionar problemas de alineación • Altas velocidades de operación
DEBILIDADES	<ul style="list-style-type: none"> • Costo elevado • El deslizamiento se vuelve más rígido mientras esta bajo carga
AMENAZAS	<ul style="list-style-type: none"> • Necesita una tolerancia de paralelismo entre sus componentes de 3 a 10 micrones/m para deslizarse sin problemas • Requiere rectificado en sus superficies de montaje y maquinado más preciso

Ya establecidas sus características se realiza una matriz FODA para cada uno de los sistemas y así identificar las correspondientes estrategias de acción.

De las diferentes estrategias de acción del análisis FODA podemos observar que el sistema Thomson nos ofrece la ventaja de tener desalineación entre los componentes conservando los coeficientes de fricción bajos y esto con la posibilidad de fabricar las piezas con maquinado convencional ya que las tolerancias que este

requiere no son cerradas y en cualquier fresadora se pueden alcanzar, esto a diferencia del sistema THK que requiere superficies rectificadas con tolerancias de hasta 10 μm lo que a su vez aumenta el costo. También se observa que los sistemas THK son más estables a altas velocidades lo cual tampoco nos interesa para nuestra aplicación. Evaluando esta información y tomando en cuenta que para nuestra aplicación en específico los sistemas Thomson nos ofrecen una solución a los problemas de fricción, superficies rectificadas, holguras, deslizamiento, método de maquinado y alineación, todo esto a menor costo, se decide utilizar un sistema de guías y baleros tipo Thomson.

4.1.3 Selección de materiales

Para la selección de materiales se consideran tres grupos de acuerdo con las funciones que las piezas realizaran dentro del diseño, segregándolos como:

- Piezas con desgaste y/o movimiento
- Piezas en contacto
- Piezas de soporte

Realizando estos tres grupos se consideran los diferentes factores de los materiales en el diseño, y se toman los diversos grupos de materiales a evaluar:

Tabla 6. Materiales y sus aspectos a evaluar.

Aspectos a evaluar	Aceros/Hierros	Aleaciones de Aluminio	Aleaciones de Cobre	Ceramicos	Polimeros
Costo	100	300	400	7000	200
Resistencia a la Fatiga	165 Mpa	131 Mpa	96Mpa	400	50
Maquinabilidad	4	5	5	1	5
Disponibilidad	5	5	4	1	3
Resistencia a la corrosion	1	2	3	5	5
Dureza	5	3	4	5	1
Resistencia a la tension	200Mpa	260Mpa	241Mpa	3000Mpa	69Mpa
Coefficiente de exp. Termica	1.2exp-5	2.4exp-5	1.7exp-5	1exp-5	
Peso	5	3	3	4	2

Como siguiente paso se utiliza el método pugh para la selección de materiales, ponderando cada uno de acuerdo con la función que va a realizar y se realiza la matriz de selección para cada uno de los tres grupos:

Materiales para fricción/movimiento

Tabla 7. Matriz de Pugh para materiales con fricción/movimiento.

MATERIALES CON FRICCIÓN / MOVIMIENTO						
	Ponderación	Aceros/Hierros	Aleaciones de Aluminio	Aleaciones de Cobre	Ceramicos	Polimeros
Costo	3	5	4	4	1	5
Resistencia a la Fatiga	2	5	4	4	5	1
Maquinabilidad	2	3	5	5	1	5
Disponibilidad	2	5	5	5	1	4
Resistencia a la corrosión	1	1	3	4	5	5
Coefficiente de Exp. Termica	3	3	4	4	4	1
	Total	51	55	56	34	43

Los resultados para el grupo de materiales que serán sometidos a fricción y/o movimiento nos arrojan que los materiales más adecuados a utilizarse son las aleaciones de cobre, por esta razón se decide utilizar un bronce comercial para este tipo de piezas.

Materiales en contacto

Tabla 8. Matriz de Pugh para materiales en contacto.

MATERIALES CON CONTACTO						
	Ponderación	Aceros/Hierros	Aleaciones de Aluminio	Aleaciones de Cobre	Ceramicos	Polimeros
Costo	3	5	4	4	1	5
Resistencia a la Fatiga	1	5	3	2	5	1
Maquinabilidad	2	3	5	5	1	5
Disponibilidad	2	5	5	5	1	4
Resistencia a la corrosión	2	3	3	3	5	5
Dureza	3	5	4	4	5	1
	Total	57	53	52	37	47

Los criterios de selección tomados en cuenta para este grupo son los mismos que en el anterior a diferencia de la dureza del material, esto debido a que se pretende evitar ralladuras o desgastes. Los resultados entonces nos indican que los

materiales más adecuados para este grupo son los hierros y/o aceros; para su selección se toma en cuenta el precio de acero para herramientas (A2, 01) contra aceros al bajo carbono (acero rolado en frío AISI 1018), dado que el precio del último es más bajo se opta por usar este.

Tabla 9. Matriz de Pugh para materiales de soporte.

	MATERIALES DE SOPORTE					
	Ponderacion	Aceros/Hierros	Aleaciones de Aluminio	Aleaciones de Cobre	Ceramicos	Polimeros
Costo	3	5	4	4	1	5
Resistencia a la Fatiga	1	5	3	2	5	1
Maquinabilidad	2	3	5	5	1	5
Disponibilidad	2	5	5	5	1	4
Resistencia a la corrosion	2	3	3	3	5	5
Peso	3	2	5	5	4	5
	Total	50	56	54	34	55

Ya que el tercer grupo de piezas solo serán de soporte, y con el objetivo de reducir en lo posible el peso se toma en cuenta este como factor de interés, por lo que sustituyéndolo en la matriz de pugh nos indica que el mejor material son las aleaciones de aluminio, por lo tanto, se opta por una aleación de aluminio 6061-T6 ya que es la de mayor uso comercial, además se opta por utilizar polímeros en piezas que fueron recicladas las cuales son de Delrin negro.

4.1.4 Mecanismo de avance

Para el mecanismo de avance se evalúa la información existente acerca de los diferentes tipos de roscas y sus aplicaciones, dentro de estas se plantean como opciones a tomar en cuenta una rosca cilíndrica unificada americana contra una rosca de perfil cuadrado (ACME) para aplicaciones de desplazamientos. Para su selección se realiza una matriz de ponderación con el método de pugh y se toman en cuenta los factores de interés en la tabla indicados:

Tabla 10. Matriz de Pugh para la selección del sistema de avance.

SISTEMA DE AVANCE			
	Ponderacion	ROSCA ACME	ROSCA AMERICANA
Costo	5	1	5
Desgaste	3	4	3
Mantenimiento	2	2	2
Disponibilidad	4	2	4
Precision	5	3	3
Transmision de potencia	1	5	2
	Total	49	48

De acuerdo con los resultados el sistema con mayores ventajas es un sistema ACME, por lo que se optó por un sistema de tornillo sin fin con este tipo de rosca.

4.1.5 Diseño conceptual

El diseño del proyecto se basó a partir del sistema mecánico en eje “Z” de una máquina de medición con sistemas de visión del laboratorio de metrología de la UACJ; como se ha mencionado anteriormente uno de los objetivos del proyecto es un bajo costo por lo que se optó el reutilizar piezas recicladas, el Dr. Javier Molina sugirió la opción de utilizar partes y componentes de proyectos ya obsoletos o no funcionales.



Figura 18. Imagen de la máquina sistema de visión.

El primer paso fue ir al laboratorio y revisar los equipos obsoletos, en donde se pudo rescatar 2 mecanismos importantes; el sistema de elevación en el eje “Z”, al hacerlo se pudo observar que contaba con piezas que provocan inestabilidad por lo que se prosiguió a la comprobación; se realizó un análisis a varias piezas donde se observó que al momento de mover el elevador en “Z” se atora y el movimiento no es uniforme, debido a que este cuenta con una varilla roscada (fig.19) la cual debía estar muy lubricada para su desplazamiento, además los orificios de las piezas de sujeción en pernos no son concéntricas y además un balero está dañado.

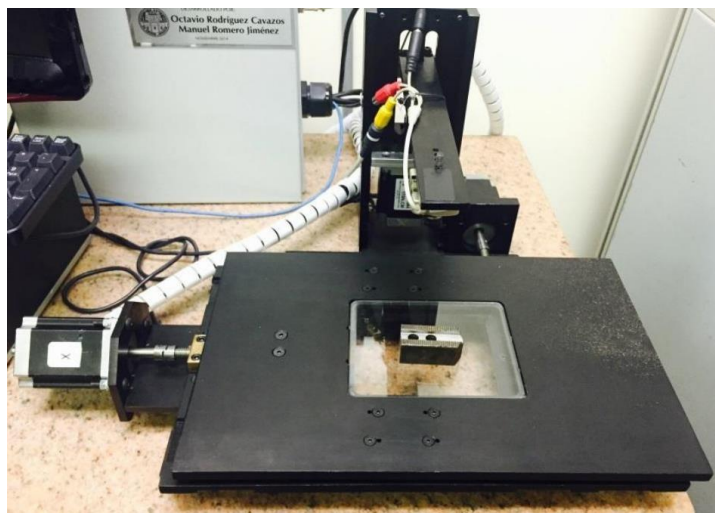

Figura 19. Sistema de desplazamiento en el eje “Z”.

también se desmontó el eje “Y” de otro proyecto el cual tenía el mismo detalle de varilla roscada en lugar de un sinfín, el cual si se utilizaba provocaría más variación en la toma de mediciones (fig. 20).



Figura 20. Varilla roscada del sistema obsoleto.

Una vez tomadas estas piezas o subensambles, se diseñó tomándolas como base para integrar el sistema de medición propuesto.

4.1.6 Diseño asistido por computadora

Para el desarrollo del concepto y la creación del diseño mecánico del mismo, se utilizó el software de diseño asistido por computadora SolidWorks [13] tomando como punto de inicio la medición de las piezas de los subensambles reciclados antes mencionados, para posteriormente integrarlos en un ambiente de ensamble (en SolidWorks) y diseñar la estructura base del dispositivo. Luego, se diseñaron piezas de sujeción tipo bracket para sostener el sistema palpador y el Chuck.



Figura 21. Interfaz SolidWorks, sub-ensamble eje “Y”.

Ya teniendo el diseño en CAD se optó por empezar a armar en lo cual se encontró con problemáticas de desplazamiento, debido a esto se requirió reemplazar algunos componentes y modificar otros, para ello se volvió al entorno de SolidWorks para analizar las partes involucradas y la integración con partes comerciales nuevas como un sistema de desplazamiento Thompson y un tornillo sinfín, tal y como muestra la figura 22.

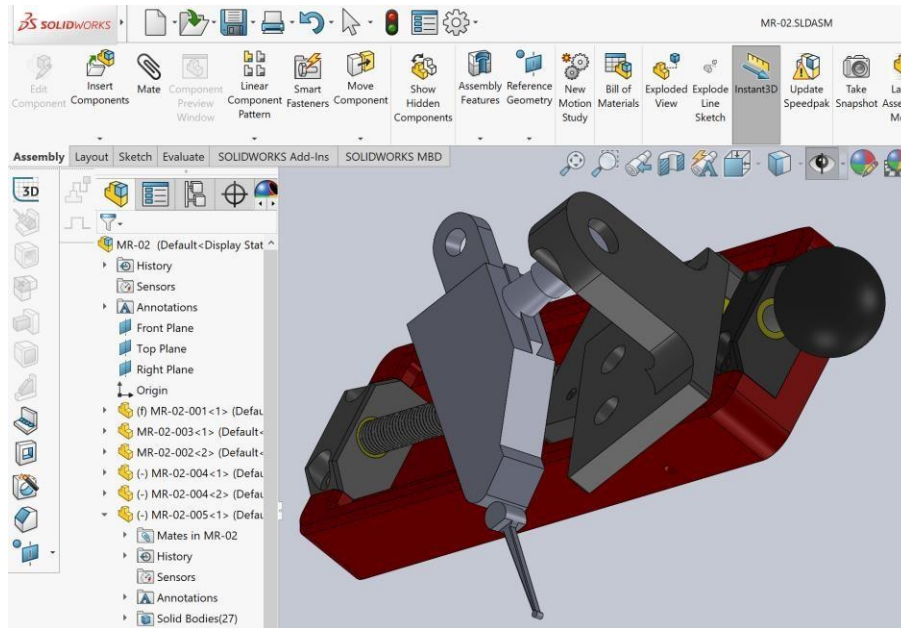

Figura 22. Imagen en 3D del sistema de desplazamiento.

4.2 Integración del sistema físico.

4.2.1 Sistema mecánico.

Las piezas manufacturadas, junto con las recicladas se integraron mediante tornillería milimétrica y estándar debido a que los sistemas de sujeción de cada subensamble reciclado eran diferentes, sin embargo, en la propuesta mostrada en CAD se maneja únicamente un tipo de tornillería.

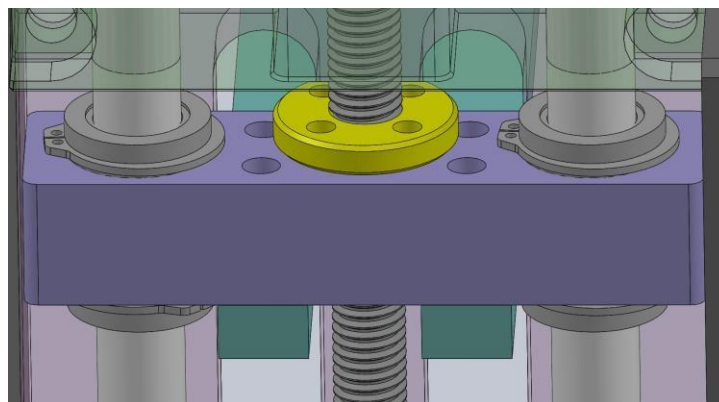
4.2.1.1 Piezas comerciales

Las piezas comerciales pueden ser localizadas en el catálogo en línea de McMastercarr [14], mismas que fueron referenciadas con su número de parte en los planos constructivos del dispositivo. A continuación, un listado de las piezas comerciales utilizadas:

-Tornillería

- Milimétrica
- Estándar

-Sistemas de desplazamiento:

- Baleros
- Pernos guía
- Manivelas giratorias
- Ball plungers

-Sistemas de ajuste:

- Chuck de 3 mordazas
- Patas con ajuste

- Nivel circular de gota
- Coples de seguridad

4.2.1.2 Piezas manufacturadas

Las piezas manufacturadas, la mayoría fueron fabricadas o retrabajadas mediante el uso de fresadora vertical convencional.



Figura 23. Maquinado de placa base.

Algunas fueron fabricadas manualmente con herramientas comunes como tornillo de banco, taladro, machuelos, entre otros, debido a la poca disponibilidad en las fresadoras se optó por realizar las piezas de características simples de esta forma.



Figura 24. Placa de aluminio fabricada manualmente.

También se retrabajaron piezas para poder tener un buen ensamblaje con componentes que minimizan la variación por vibración. Como el fijador de barras guía Thompson con el sinfín (fig. 23.) el cual tenía la rosca barrida y un balero estaba dañado, por lo que se remplazo todo el sistema de deslizamiento, con baleros y pernos guía marca Thompson.



Figura 25. Sistema de fijación de barras Thompson.

Además, en este sistema de desplazamiento en el eje "Z" se tenía el problema de desplazamiento debido a que los baleros estaban ensamblados press-fit y esto

hacia que se apretara la barra o perno Thompson y se amarrara haciéndole marcas estriadas, tal y como se muestra en la figura



Figura 26. Barra estriada y oxidada con baleros rotos.

Una vez ensamblada la torre de elevación del eje “z” se prosiguió por hacer el ensamblado del sistema de rotación, que integran: chuck de 3 mordazas, disco con balero, y el stepper.



Figura 27. Componentes del sistema de rotación.

Luego de ello, se fabrico la placa base en la que descansaran los subensambles del sistema de desplazamiento del sistema en el eje "Z" y el sistema de rotación del Chuck.



Figura 28. Ensamble del sistema de elevación en "Z" y base principal.

Se utilizaron barras de 5/8" por 7" de la marca Thompson para proporcionar la altura con unas patas ajustables de la marca Misumi. La altura se asigno en base a la dimensión del stepper que hace girar el Chuck.

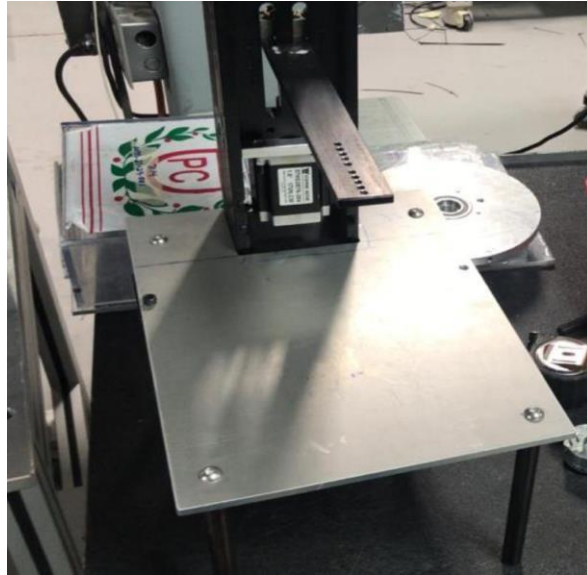

Figura 29. Patas de elevación Thompson con sistema de ajuste.

Después, se prosiguió con la fabricación de piezas y la integración del sistema de desplazamiento en eje “Y” el cual es el encargado de mover el dispositivo palpador



Figura 30. Sistema de desplazamiento en eje “Y”

En este sistema se remplazo la varilla roscada por un tornillo sinfín, ya que se barría o brincaba el bloque sin necesidad de girar la manija.



Figura 31. Subensambles principales.

Ya teniendo listos todos los subensambles se prosiguió con la integración de ellos, para luego integrar los mecanismos electrónicos.

4.2.2 Mecanismos electrónicos

Los sistemas electrónicos empleados en el desplazamiento y movimiento del sistema mecánico son 2 stepers marca Longway y un palpador LVDT marca Mitutoyo.



Figura 32. Steper Longway (izq.) Palpador Mitutoyo (der.)

Los stepers como anteriormente se menciona fueron montados en el eje de elevación del sistema de desplazamiento en “Z” y el otro en el eje de rotación del Chuck. En cuanto el sensor palpador se monto en su bracket y se analizo su movilidad y grados de libertad.

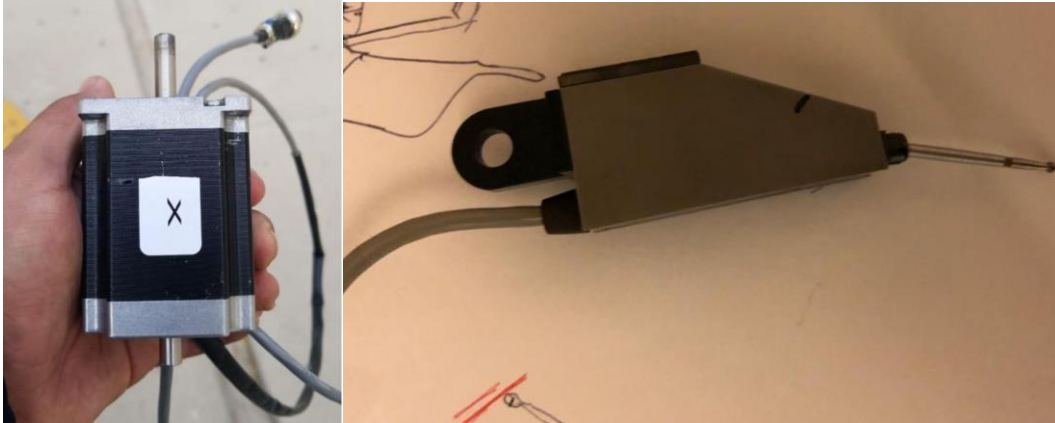

Figura 33. Dispositivo ensamblado.

4.3 Verificación del sistema físico

4.3.1 Verificación de ensamblaje del sistema mecánico

Para la verificación del sistema mecánico se verificaron los funcionamientos de:

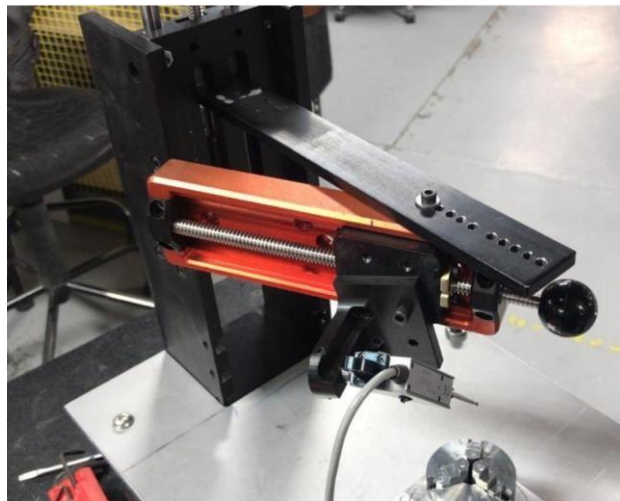
- Ejes de desplazamientos
- Rotación del balero con el plato y chuck

4.3.1.1 Verificar funcionamiento en ejes de desplazamiento



Figura 34. Barras Thompson dañadas y baleros rotos.

4.3.1.2 Verificar rotación alineada entre balero del plato y chuck

Al tener el ensamble de rotación del chuck se notó que este no giraba uniformemente, por lo que se evaluó el problema y se encontró que era debido a que el chuck descansaba en el balero el cual está ensamblado a “press fit” dentro del disco giratorio por lo que puede que las dimensiones de inserción tengan bastante variación, se decidió trabajar en una pieza en la cual descansara el chuck y además permitiera el libre movimiento del disco giratorio y del chuck.



Figura 35. Pieza diseñada para disminuir variación de giro del chuck.

Luego de integrar la pieza, el sistema de rotación con la placa tomo una nueva altura por lo que se redujo el rango de altura de medición del sistema por aproximadamente media pulgada.



Figura 36. Ensemble de pieza diseñada con placa y chuck.

Además, se retrabajo la rosca de la parte inferior del chuck debido que el cople con el que se contaba no alcanza la medida entre el stepper y el chuck y no hay otro

método de ensamblaje por lo que se optó por hacerlo mediante un tornillo de media pulgada.

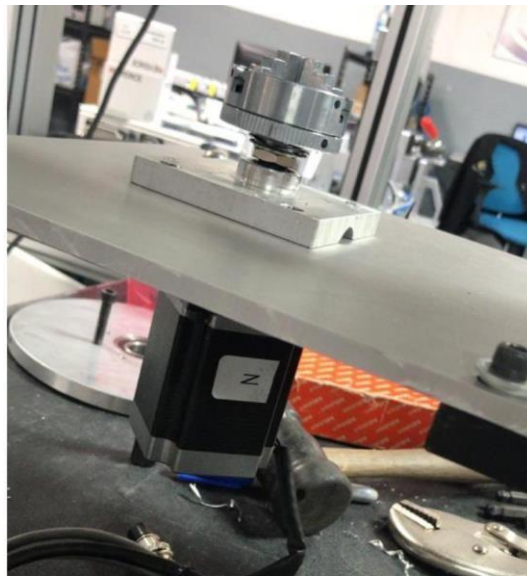
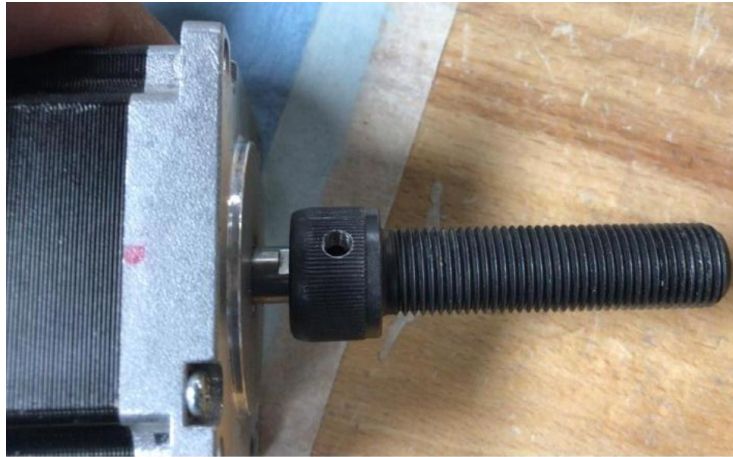

37. Cople stepper-chuck

4.3.2 Debugging del Sistema

4.3.2.1 Verificar integración de servomotores con ejes de desplazamiento

Al hacer la verificación del desplazamiento del sistema mecánico, con una aplicación de fuerza mínima los coples de seguridad se rompieron (fig. 38)



Figura 38. Cople de seguridad quebrado.

por lo que se optó por crear una pieza para el ensamble entre el sinfín y el stepper que permita el movimiento manual y eléctrico y tenga más resistencia, al momento

de las pruebas manuales, debido a esto se requirió perforar el sinfín para insertar una chaveta.



Figura 39. Sin fin de elevación del eje "Z" con cople a steper.

4.3.3 Ajuste de coordenadas iniciales en el palpado

Para el ajuste de coordenadas de inicio se determinó que el movimiento en el eje "Y" tiene que ser de una pulgada, debido a que el chuck tiene la capacidad de tomar piezas de máximo 1 pulgada de diámetro, ver figura 40.

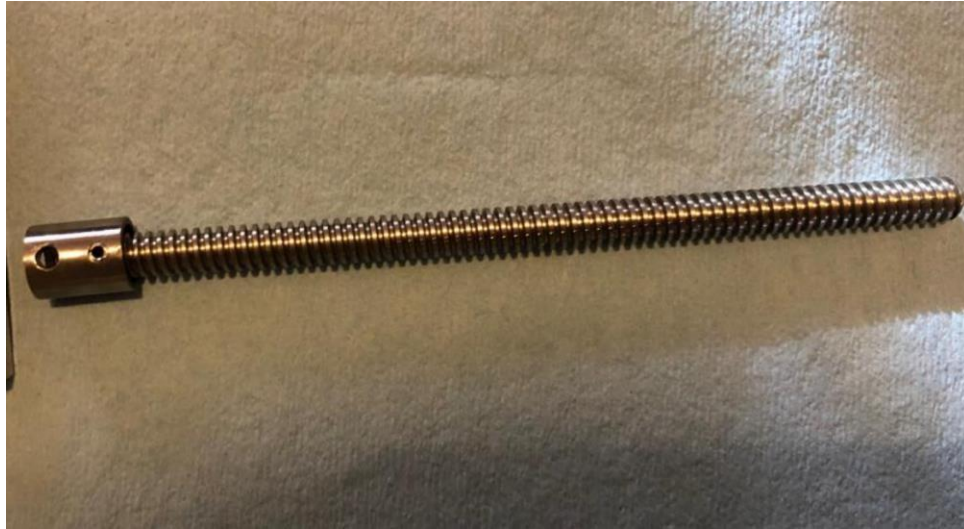

Figura 40. Chuck abierto a su máxima capacidad.

Debido a lo anterior se puso un tope que se pueda remover en un futuro cuando se cuente con un chuck que tenga la capacidad de tomar piezas de mayores dimensiones. Para el ajuste o calibración del punto inicial, se utilizó el pin gage #100 y se restó el radio de este para así obtener la alineación de la punta del palpador con el centro del chuck.



Figura 41. Palpador alineado con chuck.

Capítulo 5

5. RESULTADOS

5.1 Validación de hipótesis de precio

Como se planteó al inicio del proyecto en los objetivos se requiere que el dispositivo propuesto tenga un menor valor que la realización de un mantenimiento,

H_0 = Precio igual o mayor a un servicio de mantenimiento del equipo de medición Mitutoyo RA500H.

H_1 = El dispositivo mecánico diseñado es de menor costo que la realización de un servicio de mantenimiento al equipo Mitutoyo RA500H.

$$\begin{aligned} H_0: \mu_{Propuesta(A)} &= \mu_{RA500H} & H_1: \\ \mu_{Propuesta(A)} &< \mu_{RA500H} \end{aligned}$$

Unidad de medida: \$ precio

5.1.1 Costo de servicio de mantenimiento para RA500H

A continuación, se presenta una hoja de costos de los precios de lista o precios solicitados por Kufferath Group a su proveedor de mantenimiento de la máquina de medición de redondez, que considera entre sus puntos el coeficiente de mantenimiento, precio estimado, valor de la máquina, depreciación entre otros.

Máquina De Medicion de Redondez

Marca y modelo: MITUTOYO RA500H

Referencias Generales

Referencia	Descripción	Valor
Vm	Valor de la máquina o equipo	\$ 500,000.00
Vr	Valor de rescate de la máquina o equipo	\$ 55,000.00
Ve	Vida económica (horas efectivas de trabajo)	\$ 15,000.00
Hea	Número de horas efectivas de trabajo durante el año	\$ 30,000.00
i	Tasa de interés anual	15.00%
s	Prima anual promedio de seguros	4.00%
Ko	Coefficiente por mantenimiento tanto mayor como menor	125.00

Determinación de Costo Horario

Costos	Fórmula	Cálculo	1 al 4	4 al 8	8 al 12
			Costos por cuatrimestre		
Costos fijos					
Costo por Depreciación mensual	$D = \frac{Vm - Vr}{Ve}$	$D = \frac{445,000.00}{15,000.00}$	\$ 29.667	\$ 23.733	\$ 23.733
Costo por Inversión	$Im = \frac{(Vm + Vr) * i}{2Hea}$	$Im = \frac{83250}{60,000.00}$	\$ 1,388.000	\$ 1,388.000	\$ 1,388.000
Costo por Seguros	$Sm = \frac{(Vm + Vr) * s}{2Hea}$	$Sm = \frac{22,200.00}{60,000.00}$	\$ 840.000	\$ 840.000	\$ 840.000
Costo por Mantenimiento	$Mn = Ko * D$	$Mn = 3708.333333$	\$ 3,708.333	\$ 3,708.333	\$ 2,966.667
Suma de costos fijos=Cfi			\$ 5,966.000	\$ 5,960.067	\$ 5,218.400

Figura 42. Hoja de costeo de equipo de medición de redondez Mitutoyo RA500H.

El costo por mantenimiento se maneja por cuatrimestre por lo que son 3 anuales, dando un total de \$3,708 USD por los primeros 2 cuatrimestres y \$2,966 USD por el ultimo, como se necesita tomar en cuenta un mantenimiento para poder comprobar la primera hipótesis alterna, se decidió tomar la media de la sumatoria del costo anual, lo cual dio la cantidad de **\$3,460 USD**, para la obtención de este valor se implicó la siguiente fórmula matemática:

$$\mu = \frac{\sum X_i}{N} \quad (3)$$

5.1.2 Costeo y estimación de precios para la fabricación del dispositivo propuesto.

A continuación, se muestran las tablas de precios estimados para la fabricación del prototipo del dispositivo de medición de redondez, dividido en 2 secciones:

- Partes fabricadas y/o retrabajadas.
- Componentes comerciales.

Para la cotización de las partes se hizo una estimación de los precios con la herramienta de Dassault Systemes integrada a SolidWorks, la cual considera el precio tomando en cuenta material, método de manufactura y grado de tolerancias y las características que se le hacen a cada pieza. A continuación, en la figura 43 se puede observar un ejemplo el cual se realizó la evaluación a la pieza P/N MR03-002 “Base para Chuck”.



Figura 43. Interfaz del módulo de evaluación del Add-in a SolidWorks en el campo de costeo.

Check Active Document | SimulationXpress Analysis Wizard | FloXpress Analysis Wizard | DFMXpress Analysis Wizard | DriveWorksXpress Wizard | Costing | Sustainability | Part Reviewer

Costing

Method
Machining

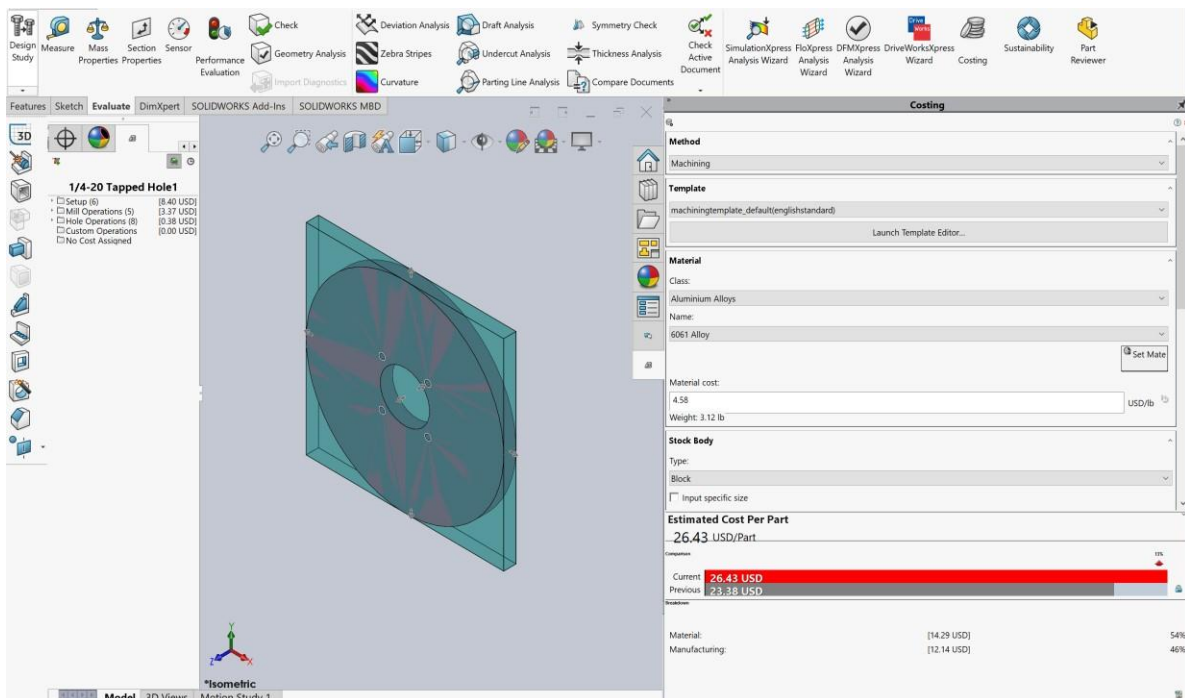
Template
machiningtemplate_default(englishstandard)
Launch Template Editor...

Material
Class: Aluminium Alloys
Name: 6061 Alloy
Material cost: 4.58 USD/lb
Weight: 3.12 lb
Set Mate

Stock Body
Type: Block
 Input specific size

Estimated Cost Per Part
26.43 USD/Part

Comparison

Current	26.43 USD	13% ↑
Previous	23.38 USD	

breakdown

Material:	[14.29 USD]	54%
Manufacturing:	[12.14 USD]	46%

Figura 44. Ejemplo de evaluación para la realización de estimación de precio.

A continuación, se muestra la tabla de las piezas fabricadas y de las comerciales que llevaron algún retrabajo ya sea un corte o cualquier proceso extra.

Tabla 11. Hoja de cálculo de los números de parte.

NEMERO DE PLANO	DESCRIPCION	REV	QTY	PRECIO	SUBTOTAL
MR-01-001	BASE INFERIOR	0	1	35	35
MR-01-002	REFUERZO LATERAL	0	2	45	90
MR-01-003	REFEUERZO LATERAL DERECHO	0	1	25	25
MR-01-004	BASE DE STEPPER	0	1	25	25
MR-01-005	PLACA GUIA EJE Z	0	1	35	35
MR-01-006	SOPORTE DE FLECHAS	0	2	20	40
MR-01-007	FLECHAS GUIAS	0	2	50	100
MR-01-008	GUIAS DE BALEROS	0	1	35	35
MR-01-009	UNION STEPPER/LEAD SCREW	0	1	30	30
MR-01-012	PLACA SOPORTE EJE Z PARA LVDT	0	1	35	35
MR-01-015	BASE PRINCIPAL	0	1	85	85
MR-01-016	FELCHAS DE SOPORTE	0	4	25	100
MR-01-017	TAPA LATERAL	0	1	20	20
MR-01-018	TAPA FRONTAL	0	1	15	15
MR-02-001	RETENEDOR LEAD SCREW	0	1	20	20
MR-02-002	SOPORTE DE LEAD Y BUJE	0	1	40	40
MR-02-003	SOPORTE PARA BUJE	0	1	35	35
MR-02-004	BUJE PARA LEAD SCREW	0	2	25	50
MR-02-005	LEAD SCREW M8 X 200MM	0	1	N/A	N/A
MR-02-006	PLACA GUIA LEAD SCREW	0	1	65	65
MR-02-007	BRACKET PARA PALPADOR	0	1	45	45
MR-03-002	BASE DE CHUCK	0	1	25	25
MR-03-003	ESPACIADOR PARA STEPPER	0	1	15	15
MR-03-004	TORNILLO SHCS 1/20-20	0	1	5	5
					970
					TOTAL

La tabla siguiente muestra las piezas comerciales empleadas en la integración del dispositivo propuesto.

Tabla 12. Hoja de cálculo de los componentes y partes comerciales.

PART NUMBER	DESCRIPTION	SUPPLIER	QTY	PRICE PER UNIT	SUB-TOTAL
LVBM8-20	LEVELING BOLTS-STANDARD TYPE	MISUMI	4	\$15	\$60
57HS2B76-384	HYBRID STEPPING MOTOR WITH ENCODER	LONG WAY MOTORS	2	\$55	\$110
LEAD SCREW NUT	LEAD SCREW NUT THREAD M8	MISUMI	2	\$15	\$30
97633A230	EXTERNAL BALL BEARING	MCMaster-CARR	4	\$25	\$100
6630K12	LINEAR BALL BEARING	MCMaster-CARR	2	\$45	\$90
MTSBR8-160	LEAD SCREW THREAD M8 X 160MM	MISUMI	1	\$60	\$60
519-331	PLAIN TYPE CARTRIDGE HEAD PROBE	MITUTOYO	1	\$465	\$465
519-331-1	BRACKET FOR PLAIN TYPE CARTRIDGE HEAD PROBE	MITUTOYO	1	\$35	\$35
MTR8-200	LEAD SCREW THREAD M8 X 200MM	MISUMI	1	\$85	\$85
61095K32	BALCK PLASTIC BALL KNOB	MCMaster-CARR	1	\$35	\$35
91078A225	STEEL HEX NUT 1/2-20	MCMaster-CARR	1	\$5	\$5
9714K1	WAVE WASHER	MCMaster-CARR	1	\$3	\$3
					1078
					TOTAL

Tomando en cuenta las piezas fabricadas o retrabajadas, componentes y partes comerciales se sumaron sus precios y se obtuvo el total de \$2,048 USD mediante la siguiente formula:

$$\Sigma = (X_1 + X_2 + \dots + X_n) \quad (4) \quad \mathbf{5.1.3 \text{ Comprobación de hipótesis alterna}}$$

H_1 = El dispositivo mecánico diseñado es de menor costo que la realización de un servicio de mantenimiento al equipo Mitutoyo RA500H.

$$\mathbf{H_1: \mu_{Propuesta (A)}(\$2,048) < \mu_{RA500H}(\$3,460)}$$

Se puede notar que la diferencia es significativa, ya que la propuesta (A) es \$1,412 USD más económica que el realizar un mantenimiento al equipo de medición de redondez de la marca Mitutoyo modelo RA500H el cual es empleado por la empresa Kufferath para realizar las mediciones correspondientes actualmente.

5.2 Validación de hipótesis de menor porcentaje de error en mediciones

Como se planteó al inicio del proyecto en los objetivos se requiere que el dispositivo propuesto debe proporcionar una menor variación al momento de la adquisición de datos de medición con respecto a los que se obtengan mediante el uso de un sistema manual (B); lo anterior mencionado se lleva a cabo evaluando la variación de los datos obtenidos entre los métodos (A) y (B) midiendo pin gages de diferentes diámetros.

H_1 : El dispositivo diseñado (A) es capaz de proporcionar lecturas de medición de circularidad más precisas que con el sistema de medición manual (B).

$$H_0: \mu\%E(A) \Rightarrow \mu\%E(B)$$

$$H_1: \mu\%E(A) < \mu\%E(B)$$

5.2.1 Entorno y características técnicas para la realización del muestreo

Las corridas para efectuar la validación se realizan en las instalaciones del laboratorio de electrónica del edificio Y4 del instituto de IIT de la UACJ, en ciudad Juárez, Chihuahua, México. Las corridas se llevaron a cabo bajo una temperatura artificial de 26 grados centígrados, las piezas o probetas sujetas a medición son 3 pin gage de la marca Mitutoyo fabricados en acero 1045, sus números son #60, #80, #100. para efectuar las mediciones se tomaron 20 muestras de cada pieza por 2 operadores.

5.2.1.1 Determinación de las características de las piezas sometidas al proceso de medición.

Las piezas que están sometidas al ejercicio de medición son de forma cilíndrica.

5.2.1.2 Determinar las medidas nominales de la probeta (pieza).

Para la determinación de las medidas nominales de la pieza se tomó como probeta de referencia los pin gage #100 (.250 in), #80 (.213 in), #20 (.100 in) de la marca Mitutoyo mostrado en la figura 45.

Figura 45. Pin gage #100 de la marca Mitutoyo.



- Dimensiones de la pieza en cuestión: el diámetro de la probeta es de 6.36 mm (.250 in), y su longitud de 50.80 mm (2.00 in).
- Material de la pieza: Los materiales más asequibles que presentan buenas propiedades de mecanizado, como lo son buen acabado y la maquinabilidad son el bronce, acero y el aluminio. En este ejercicio se emplea una pieza fabricada en acero.

5.2.1.3 Descripción del método del círculo de mínimos cuadrados para realizar la medición de la redondez.

Se dibuja un círculo circunscrito y un inscrito en el perfil polar, (ver figura 46) y el valor de salida de la redondez es la separación radial de estos dos círculos. El centro

de estas dos variables es el mismo, y su exactitud depende del número de puntos adoptados en la medición del perfil. El cálculo manual de este método es arduo y consume mucho tiempo, pero los nuevos instrumentos digitales simplifican el proceso considerablemente.



Figura 46. Diagrama polar de círculo de mínimos cuadrados

5.2.2 Simulación del proceso de medición

5.2.2.1 Descripción del proceso de medición

Para determinar los parámetros y las variables que se requieren para la simulación de la medición de la redondez de una pieza cilíndrica, los pasos propuestos se exponen a continuación.

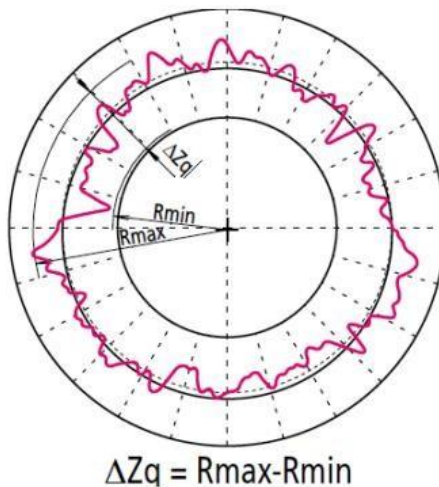
- Paso 1. Se ubica la pieza como se muestra la figura 47, de tal manera que el LVDT o palpador análogo este paralelo a ésta.



Figura 47. Centrado de pieza con palpador.

- Paso 2. El LVDT debe estar en contacto con la pieza, (cuya longitud es 50.8 mm, y el diámetro de 6.36 mm).
- Paso 3. Para la sujeción de la probeta se usa un chuck o mandril, en donde se sostiene la pieza por la presión generada a partir de 3 mordazas; que es movido en movimiento rotacional por medio de un motor a pasos “steper”, es importante mencionar que dicho movimiento debe ser lento para evitar rebotes.

Parámetros.

- Diámetro nominal de la pieza. (D_n): 6.36 mm
- Radio nominal de la pieza. (R_n) $R_n = \frac{D_n}{2} = \frac{6.36}{2} = 3.18$ mm
- Longitud de la pieza. (L) 50.8 mm

Variables

- Paralelismo entre pieza y palpador LVDT.

-Velocidad angular del motor. (W_m). Se define como el cociente entre el ángulo central descrito por el motor y el tiempo empleado en recorrerlo.

- Velocidad angular transmitida a la probeta (W_o)

Tiempo (T_o) - θ_0 y θ_m Angulo recorrido, si el caso fuera un motor paso a paso para conocer la posición angular de la pieza.

Tabla 13. Variables y parámetros del proceso.

Variable	Indicadores
Diámetro nominal (D_n)	mm
Radio nominal (R_n)	mm
Resistencia (R)	Ω
Frecuencia (f)	Hz
Desplazamiento (δ)	mm
Velocidad Angular (W)	RPM ó rad/s
Angulo Recorrido (θ)	$^\circ$ ó rad
Periodo (T)	s
Relación de Transmisión Poleas (n)	Adimensional
Variación Radial (r_y)	mm
Valor Medido Redondez (R)	mm

5.2.2 Validación estadística

Para su validación estadística se toman muestras de los datos obtenidos en mini volts (mV) por el sensor palpador (ver figura 48) en cada una de las mediciones y se almacenan en una hoja de datos, mediante una hoja de cálculo se hace la conversión de los datos obtenidos a datos de medición en unidades del sistema internacional (SI).

Fecha	N. lecturas	Medicion	Mv	N. Lectura	mm.
11/26/2018 06:16:11.766 PM	0	110			
11/26/2018 06:16:11.811 PM	1	120	0	0	
11/26/2018 06:16:11.812 PM	2	250	10	1	0.060571
11/26/2018 06:16:11.813 PM	3	360	20	2	0.121142
11/26/2018 06:16:11.814 PM	4	440	30	3	0.181713
11/26/2018 06:16:11.816 PM	5	480	40	4	0.242284
11/26/2018 06:16:11.818 PM	6	520	50	5	0.302855
11/26/2018 06:16:11.820 PM	7	620	60	6	0.363426
11/26/2018 06:16:11.821 PM	8	580	70	7	0.423997
11/26/2018 06:16:11.822 PM	9	630	80	8	0.484568
11/26/2018 06:16:11.824 PM	10	1050	90	9	0.545139
11/26/2018 06:16:11.825 PM	11	1000	100	10	0.60571
11/26/2018 06:16:11.826 PM	12	940	110	11	0.666281
11/26/2018 06:16:11.827 PM	13	890	120	12	0.726852
11/26/2018 06:16:11.829 PM	14	850	130	13	0.787423
11/26/2018 06:16:11.831 PM	15	810	140	14	0.847994
11/26/2018 06:16:11.833 PM	16	760	150	15	0.908565
11/26/2018 06:16:11.834 PM	17	720	160	16	0.969136
11/26/2018 06:16:11.835 PM	18	680	170	17	1.029707
11/26/2018 06:16:11.836 PM	19	650	180	18	1.090278
11/26/2018 06:16:11.838 PM	20	620	190	19	1.150849
11/26/2018 06:16:11.839 PM	21	580	200	20	1.21142
11/26/2018 06:16:11.840 PM	22	550	210	21	1.271991
11/26/2018 06:16:11.841 PM	23	520	220	22	1.332562
11/26/2018 06:16:11.843 PM	24	490	230	23	1.393133
11/26/2018 06:16:11.844 PM	25	470	240	24	1.453704
11/26/2018 06:16:11.845 PM	26	440	250	25	1.514275
11/26/2018 06:16:11.846 PM	27	420	260	26	1.574846
11/26/2018 06:16:11.847 PM	28	400	270	27	1.635417
11/26/2018 06:16:11.848 PM	29	380	280	28	1.695988
11/26/2018 06:16:11.849 PM	30	360	290	29	1.756559
11/26/2018 06:16:11.853 PM	31	330	300	30	1.81713
11/26/2018 06:16:11.855 PM	32	310	310	31	1.877701
11/26/2018 06:16:11.856 PM	33	300	320	32	1.938272
11/26/2018 06:16:11.857 PM	34	280	330	33	1.998843
11/26/2018 06:16:11.859 PM	35	260	340	34	2.059414
11/26/2018 06:16:11.860 PM	36	250	350	35	2.119985
11/26/2018 06:16:11.862 PM	37	230	360	36	2.180556
11/26/2018 06:16:11.863 PM	38	220	370	37	2.241127
11/26/2018 06:16:11.864 PM	39	210	380	38	2.301698

Figura 48. Fragmento de hoja de calculo de lecturas del palpador.

Una vez ya obtenidos estos datos de medición en milímetros, mediante la herramienta minitab se interpreta el comportamiento de los datos y se identifica el tipo de distribución que siguen cada uno de ellos utilizando una prueba de normalidad; para conocer su variación y visualizar de mejor manera el comportamiento de estos datos se origina un resumen como otro proceso de

validación se realiza un estudio MSA de gage R&R cruzado para conocer el comportamiento del equipo de medición.

Para conocer los parámetros de operación del dispositivo (A) se le montan unas piezas probeta de la marca Mitutoyo #100 la cual tiene .250 in (6.36 mm) (+/-2µin) y #80 la cual tiene 5.41 mm y mismas tolerancias que la anterior, las mediciones obtenidas se observan los siguientes graficas:



Figura 49. Histograma de pin gage #100.

Se realizaron 20 lecturas del pin gage #100, 10 por operador, como se puede observar en el histograma los datos de medición tienden a estar cargados a la derecha por lo que su media es 6.38 mm, 2 mm arriba de la dimensión nominal del pin gage sometido a medición (6.36 mm) la cual esta marcada en rojo.

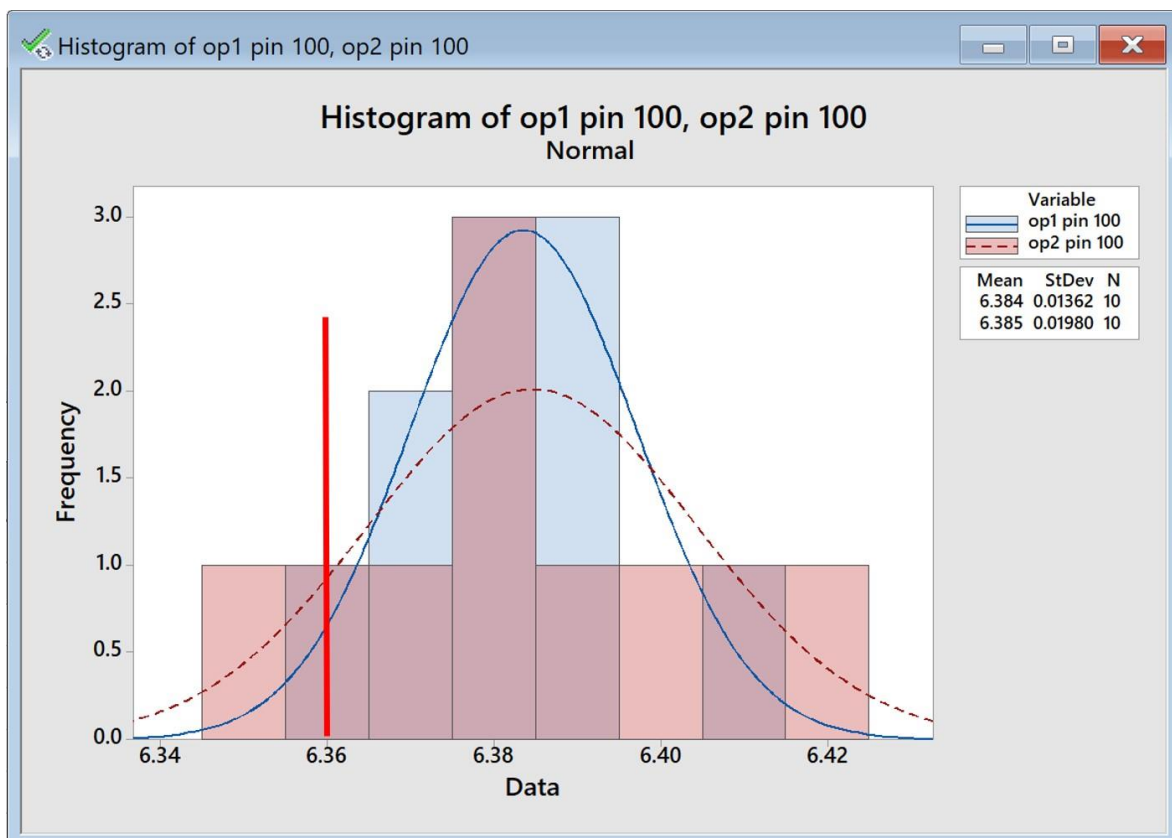

Figura 50. Histograma de pin gage #80.

Para el caso del pin gage #80 se sometio al mismo tipo y cantidad de pruebas, de las cuales se puede observar que la distribución de las lecturas estan cargadas a la derecha y significativamente alejadas de la medida nominal 5.41 mm, la media de las 20 mediciones es 5.456 mm, lo cual es aproximadamente 0.05 mm de error, significativo para este tipo de dispositivos de medicion.

5.2.2.1 Determinación de distribución de los datos.

Se realizo una prueba de normalidad para conocer la distribución de los datos obtenidos, esta se realizó con el método de Ryan-Joyner; de acuerdo con el valor P de esta prueba se deduce que el comportamiento de los datos es normal.

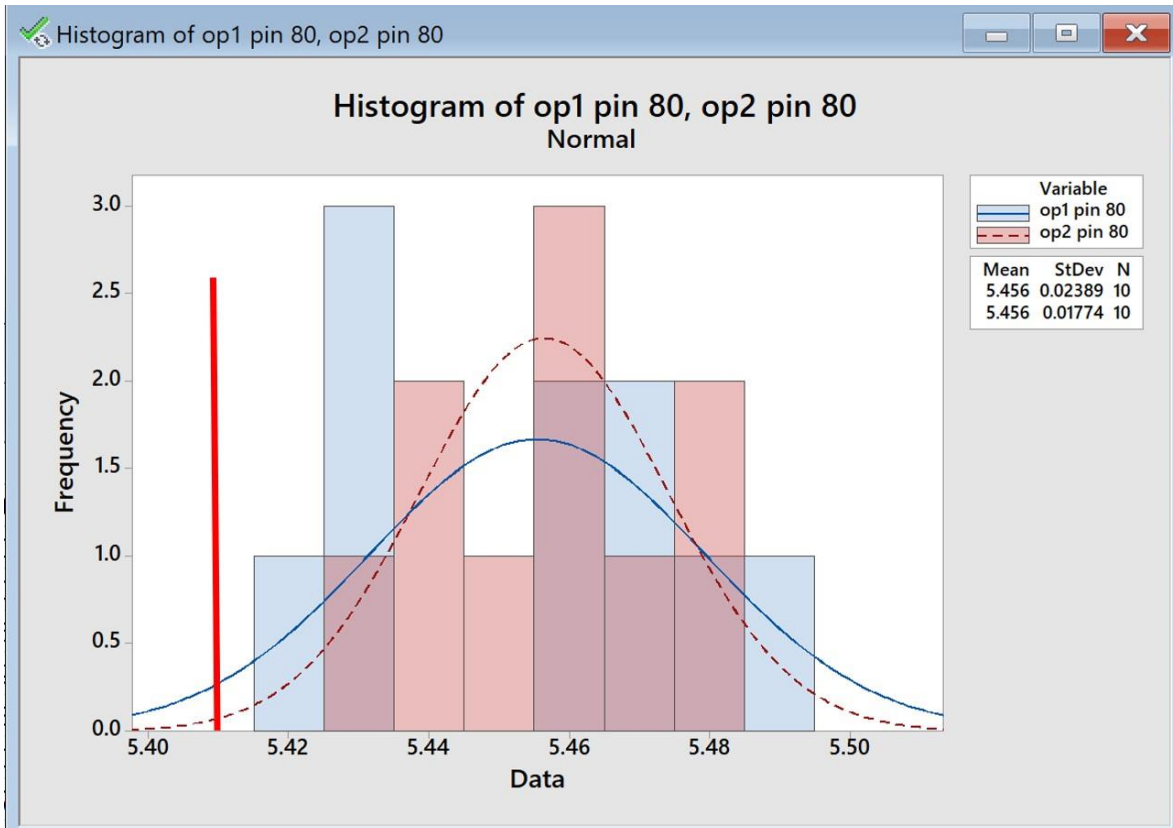

Figura 51. Gráficos de distribución del muestreo del pin gage #100.

Así mismo la gráfica para el pin gage #80 nos muestra mediante el valor de P que es una distribución normal.

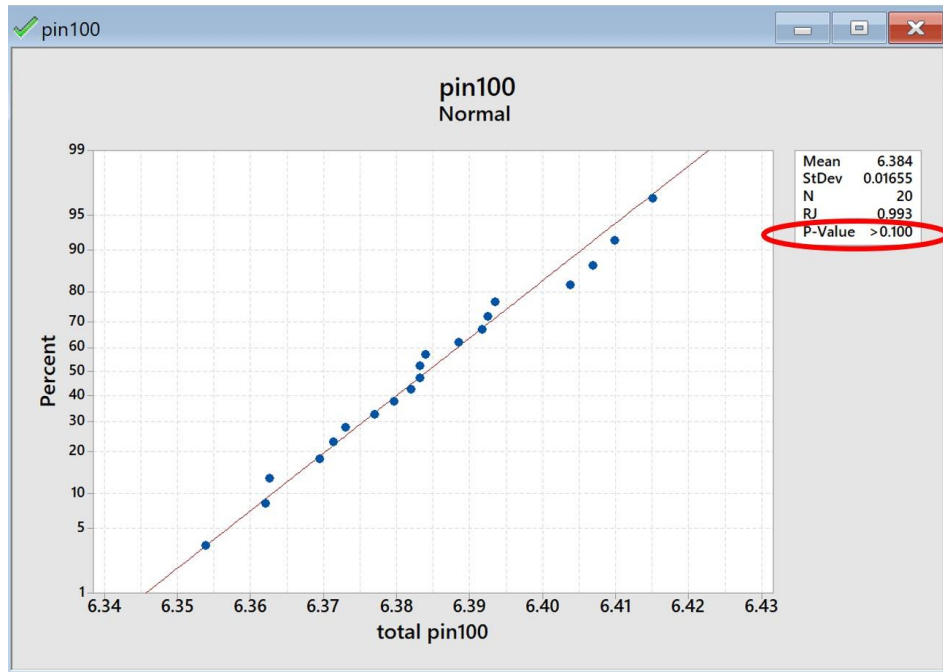

Figura 52. Gráficos de distribución del muestreo del pin gage #80.

5.2.2.2 Estudio de estabilidad

Para determinar si el nuevo instrumento de medición es aceptable se realiza un estudio de estabilidad:

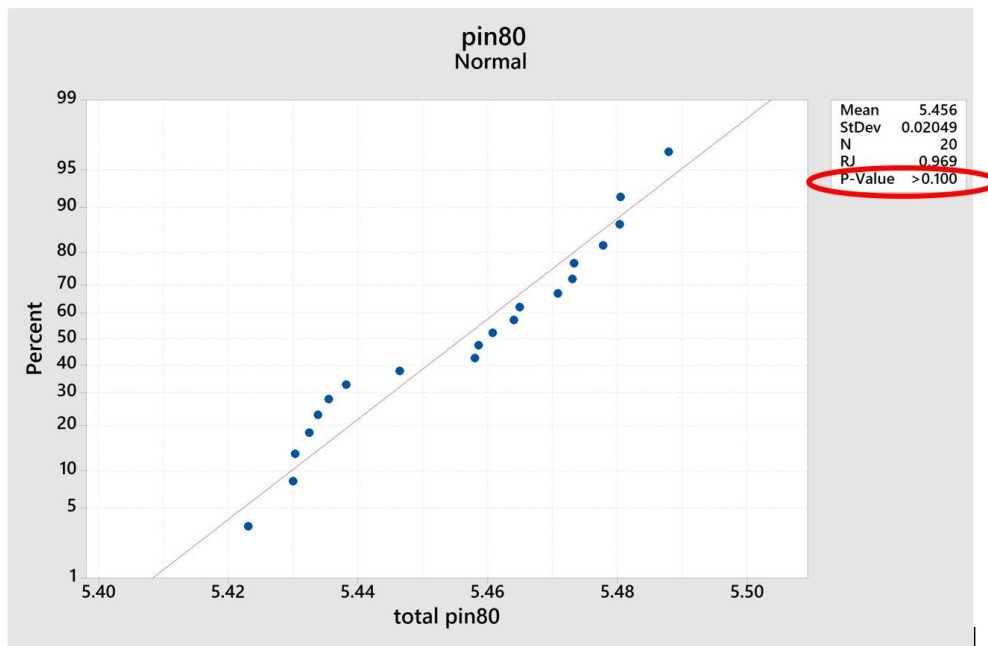

Figura 53. Gráficos de estudio de estabilidad de las mediciones en pin gage #100.



Figura 54. Gráficos de estudio de estabilidad de las mediciones en pin gage #80.

se determina que el equipo es exacto mas no preciso debido a que a pesar de que no muestra variación considerable en la adquisición de datos, estos no se encuentran concentrados en su nominal.

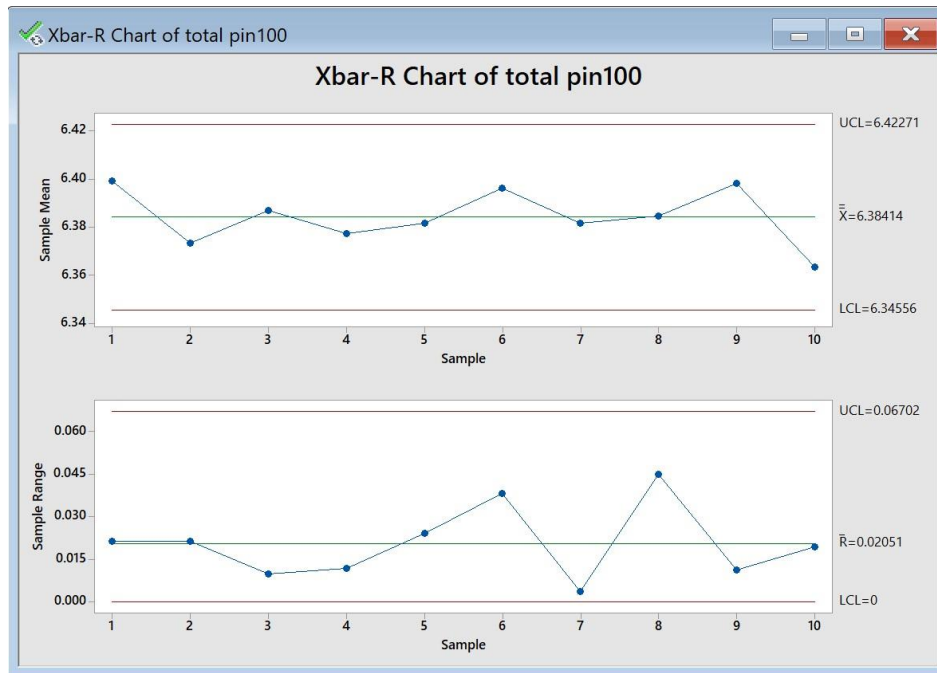
5.2.2.3 Estudio de linealidad y sesgo

Con el tamaño de muestra previamente calculado se realiza un estudio de linealidad para determinar la exactitud del instrumento a lo largo de su rango de trabajo. Tal y como se muestra en la figura 55:

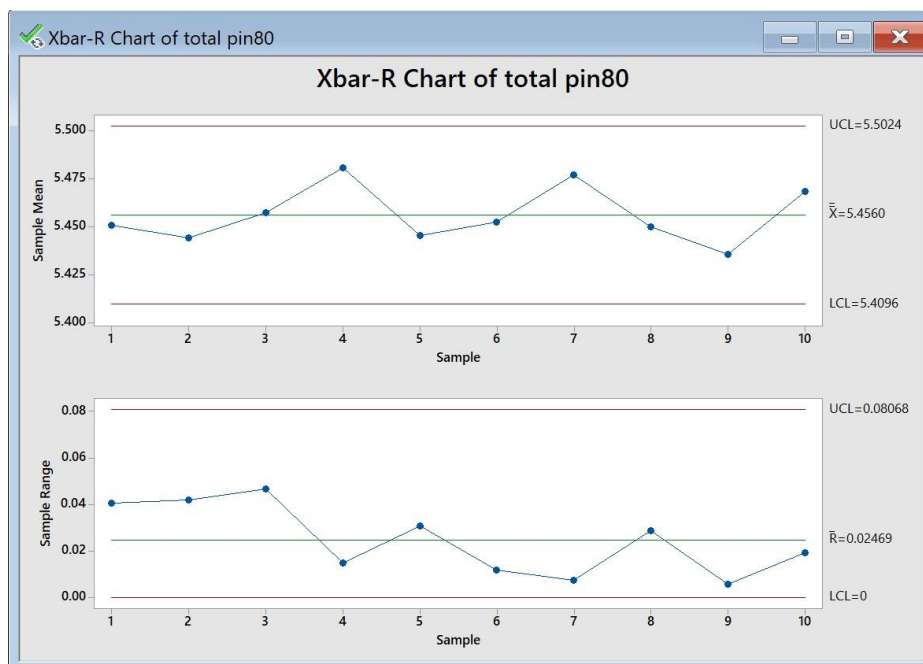

Figura 55. Grafico de linealidad y sesgo.

De la gráfica se observa que la linealidad es responsable del 2.2 % de la variación total, así mismo se aprecia un .2% en promedio para el sesgo y basados en el estadístico P, el sesgo promedio en el sistema no es significativo.

5.2.2.4 Estudio de Reproducción y Repetibilidad.

Puesto que el estudio de linealidad y sesgo evalúa la variación en el equipo, se realiza un gage R&R el cual identifica si todo el sistema de medición es aceptable; para esto se evalúan 2 piezas diferentes y de cada una se toman 10 mediciones, esto lo realiza una vez cada operador (2), se registran los datos y se obtiene la siguiente información.

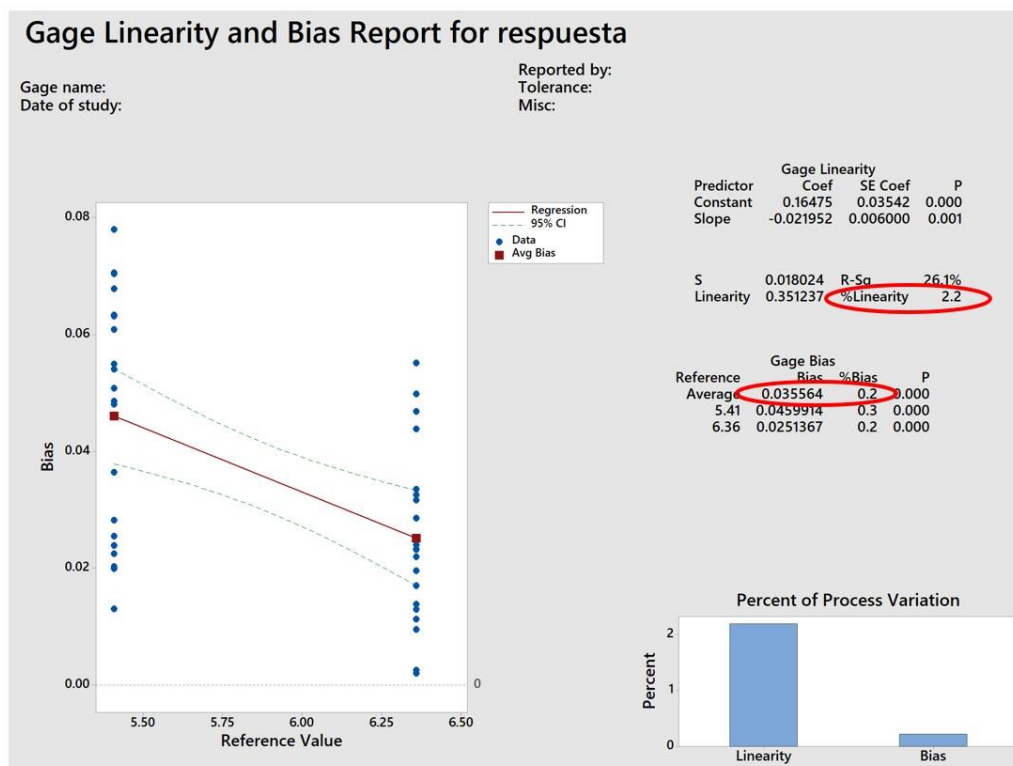

Figura 56. Six pack de gage R&R para las mediciones.

De acuerdo con los datos, el porcentaje de variación se debe a los siguientes factores:

- Sistema de medición (repetibilidad). 94.37%
- Parte a parte. 5.63 %

Hoja de sesión de Minitab

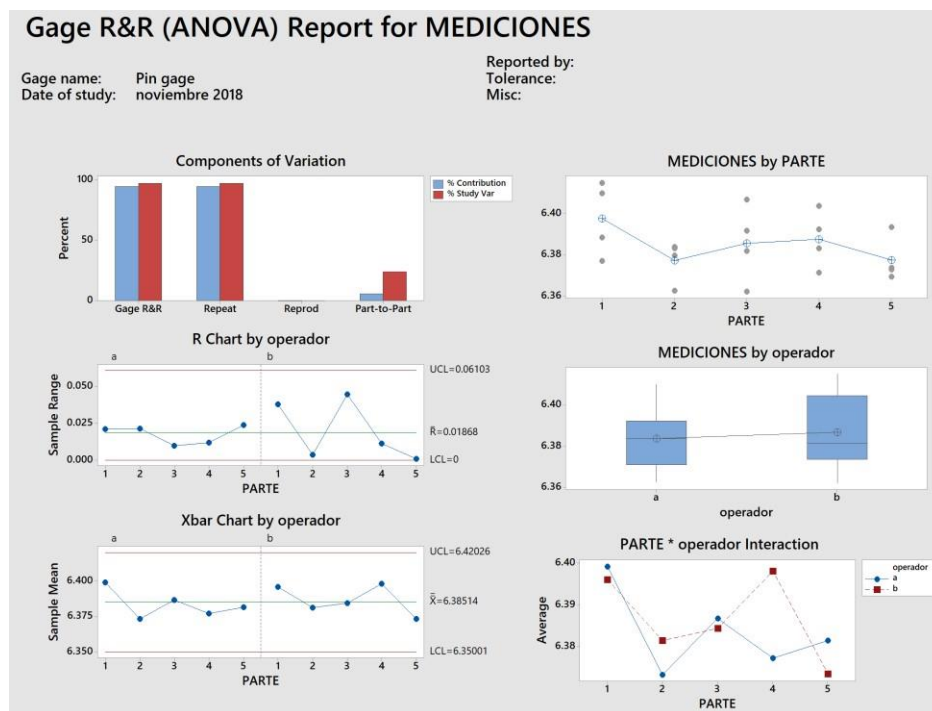
Gage R&R

%Contribution		
Source	VarComp	(of VarComp)
Total Gage R&R	0.0002281	94.37
Repeatability	0.0002281	94.37
Reproducibility	0.0000000	0.00
operador	0.0000000	0.00
Part-To-Part	0.0000136	5.63
Total Variation	0.0002417	100.00

Study Var	%Study Var		
Source	StdDev (SD)	(6 × SD)	(%SV)
Total Gage R&R	0.0151023	0.0906137	97.15
Repeatability	0.0151023	0.0906137	97.15
Reproducibility	0.0000000	0.0000000	0.00
operador	0.0000000	0.0000000	0.00
Part-To-Part	0.0036871	0.0221227	23.72
Total Variation	0.0155459	0.0932751	100.00

Number of Distinct Categories = 68

En la gráfica de barras se muestra que la gran parte de la variación se debe a la repetibilidad de las mediciones, ya que en la gráfica de puntos no se ve influencia en la reproducibilidad, además en la gráfica de cajas se aprecia que no existe diferencia entre cada operador y en la gráfica parte-operador se corrobora que los operadores siguen un mismo patrón en sus mediciones.

5.2.3 Evaluación del prototipo

De los datos incluidos en el estudio inicial del prototipo actual se determina que su error oscila en el 1.5 % esto debido a la alineación del motor a pasos con el chuck lo que nos indica una elevada variación para este tipo de dispositivos que deben ser muy precisos exactos, por lo tanto, se analiza el prototipo y sus características con un diagrama de Ishikawa.



Figura 57. Diagrama de pescado/Ishikawa para la variación en el equipo.

Como se observó en el diagrama de pescado el problema de la precisión viene dado a raíz de varios factores, dentro de ellos se encuentra como principal el chuck de 3 mordazas el cual tiene varias características simuladas y no es un componente fabricado con precisión, la alineación de la flecha del stepper al chuck, el stepper amarrado, la fricción en los componentes, el sistema de desplazamiento y las

imprecisiones que existen entre los componentes maquinados que están en movimiento e interactúan entre ellos al momento de estar en operación.

5.2.4 Error Elíptico

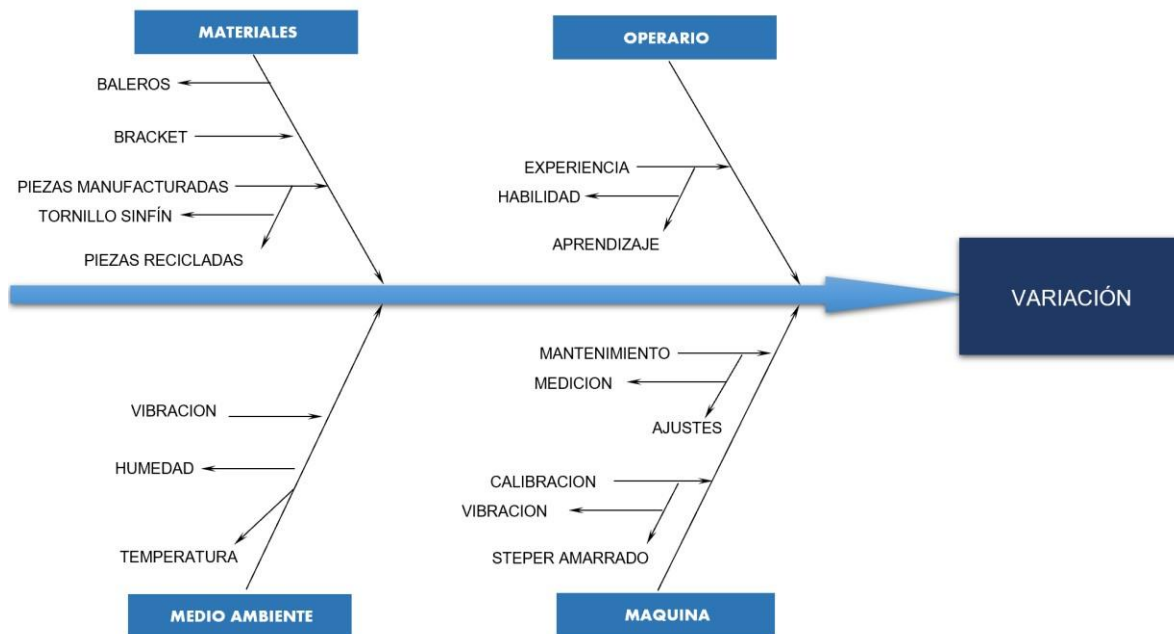
Como ya se mencionó el factor determinante para la variación en la toma de datos es la deficiente alineación en el chuck, el cual no es paralelo a la punta del sensor palpador LVDT y da como resultado la lectura de elipses en vez de círculos (ver figura 58), por lo que se decidió eliminar las lecturas que dieran el diámetro nominal, las cuales están presentes al momento que el sensor no palpa la probeta, a pesar que hay secciones donde el palpador tiene un contacto más fuerte con la pieza este no influye en la toma de la medición ya que la resolución que maneja el sensor esta acotada.



Figura 58. Inclinación contra error elíptico

Capítulo 6

6. CONCLUSIONES

1. Para poder obtener datos de medición con la misma resolución con la que cuenta el sistema palpador LVDT los componentes del sistema mecánico deben ser manufacturados con herramientas que proporcionen al menos el mismo grado de precisión que tienen en sus especificaciones técnicas.

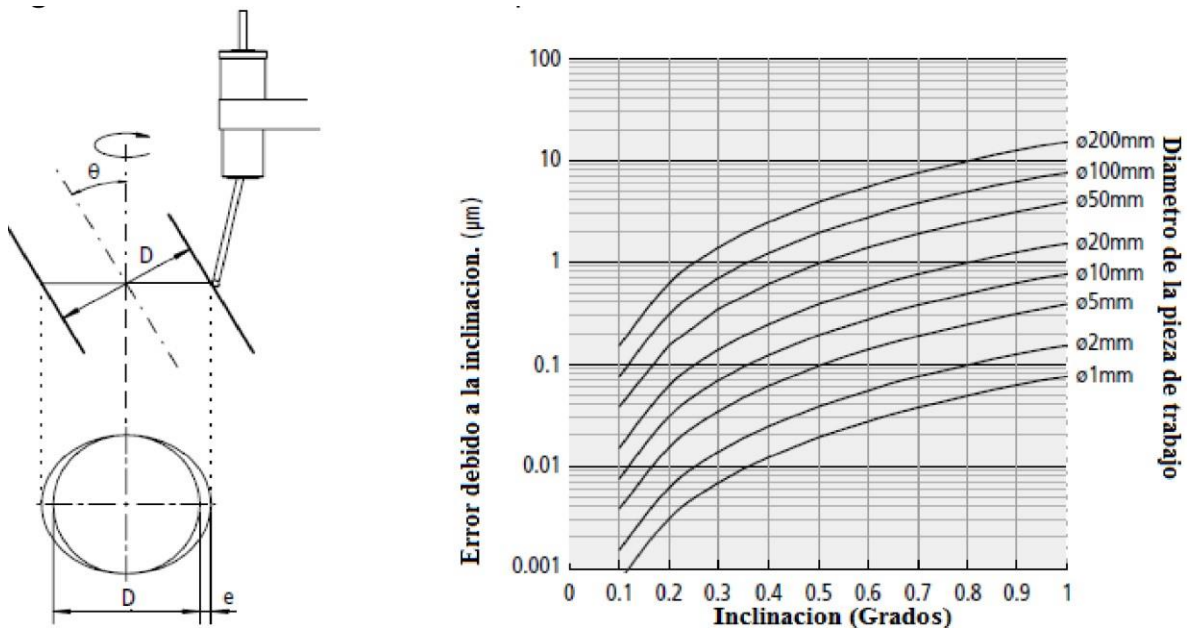
2. Otro de los factores puramente mecánicos se observa que algunas de las causas principales por las cuales el prototipo presenta amplio rango de variación son la holgura y la alineación en los mecanismos utilizados, esto ocasionado por los ajustes deficientes (juego entre piezas) o por la calidad de los componentes comprados como el chuck, motores a pasos, tornillos sin fin; además de la disposición de los mecanismos utilizados.

3. Al evaluar la forma en que se realiza la medición de la redondez, se observó que es necesario un procedimiento más sofisticado para la adquisición de los datos de medición de la pieza, y que estos se puedan interpretar de forma más simple.

4. La operación de cilindrado es el proceso de mecanizado más empleado en la fabricación de piezas de forma circular, para lograr obtener los datos de una pieza

bajo esta característica es necesario realizar cálculos matemáticos elevados para la obtención de las espirales.

5. Se observó que mediante el uso de programas especializados se puede realizar una interfaz hombre máquina que permite una simulación de un proceso físico como es la medición de la redondez mediante el uso de un sensor palpador LVDT.

7. BIBLIOGRAFIA



- [1] Rodríguez Cavazos Octavio, *rediseño e integración mecánica de un sistema de medición por coordenadas para dos dimensiones, universidad autónoma de ciudad Juárez, México*. Pp. 1-2.
- [2] Pérez Castro, Wilson, *Diseño de un Rugosímetro digital por palpación Tecnólogo en Mecánica*. Pereira, Risaralda. *Escuela de Tecnología Mecánica* 2.005, pp. 112-120.
- [3] Kufferath Group de Mexico, <http://es.kufferath-group.com/empresa.html>
- [4] Mitutoyo, sistema palpador LVDT 519-031, [https://shop.mitutoyo.eu/web/mitutoyo/en_AT/mitutoyo/\\$catalogue/mitutoyoData/PR/519-331/datasheet.xhtml;jsessionid=B8CDE829476BED05DF3788E610410B78](https://shop.mitutoyo.eu/web/mitutoyo/en_AT/mitutoyo/$catalogue/mitutoyoData/PR/519-331/datasheet.xhtml;jsessionid=B8CDE829476BED05DF3788E610410B78)
- [5] J. Ferguson, "Circularity tolerance evaluation considering roundness error," *Precision Engineering*, vol. 38, No.5, (2012) pp. 154-161.
- [6] H. Geng, *Manufacturing Engineering Handbook*, Estados Unidos de América: McGraw-Hill, 2004.
- [7] Disponible en internet: https://www.ecured.cu/Historia_de_la_medici%C3%B3n (consultado en noviembre de 2018).
- [8] H. Chang, T.V. Lim, "Evaluation of circularity tolerance using Monte Carlo simulation for coordinate measuring machine," *International Journal of Production Research* 31 (1993) 2079-2086.
- [9] X.M. Li., Z.Y Shi, " The relationship between the minimum zone circle and the maximum inscribed circle and the minimum circumscribed circle," *Precision Engineering*, vol. 33, No.3, pp. 284-290.
- [10] E.S. Gadelmawla, "Simple and efficient algorithms for roundness evaluation from the coordinate measurement data," *Measurement*, Vol. 43, No.2, pp. 223-235, February 2010
- [11] ANSI/ASME Y14.5M, *Dimensioning and Tolerancing*, American Society of Mechanical Engineers, New York, 1982.

- [12] C. Mu-Chen, T. Du-Ming, T. Hsien-Yu, "A stochastic optimization approach for roundness measurements", *Pattern Recognition Letters* 20 (1999) 707-719
- [13] Wentao Sui, Dan Zhang, "Four Methods for Roundness Evaluation", *International Conference on Applied Physics and Industrial Engineering* (2012) 20 2160-2164.
- [14] Disponible en internet: https://www.mitutoyo.com/wp-content/uploads/2016/03/MuChecker_2215-1.pdf (consultado en noviembre de 2018).
- [15] Disponible en internet: <http://www.ni.com/en-us/shop/labview/labview-details.html> (consultado en noviembre de 2018).
- [16] Disponible en internet: <https://www.ni.com/data-acquisition/what-is/> (consultado en noviembre de 2018).
- [17] Disponible en internet: <https://ceti-y-las-comunicaciones.webnode.mx/parcial-2/sensorestransductores-y-actuadores/> (consultado en noviembre de 2018).
- [18] Disponible en internet: <https://sites.google.com/site/infoalmadraba/el-ordenador> (consultado en noviembre de 2018).
- [19] Disponible en internet: <http://www.areatecnologia.com/informatica/que-es-software.html> (consultado en noviembre de 2018).
- [20] Disponible en internet: <https://www.nist.gov/pml/weights-and-measures/laboratory-metrology> (consultado en noviembre de 2018).
- [21] Disponible en internet: CIENTEC, sistemas de medición de redondez R100, <http://www.cientec.com.mx/es/sistemas-de-medicion-de-redondez-2> (consultado en noviembre de 2018).
- [22] Disponible en internet: <http://www.ciens.ucv.ve:8080/generador/sites/martinezma/archivos/Calibracion.pdf> (consultado en noviembre de 2018).

8. ANEXOS

MATERIAL		STOCK SIZE			CYLINDER STOCK SIZE		DESIGNED BY:	DRAWN BY:	APPROVED BY:	REVIEWED BY:
N/A		THK	W	L	Ø	L	JOSÉ FÉLIX	JOSÉ FÉLIX	JAVIER MOLINA	JAVIER MOLINA
N/A		N/A	N/A	N/A	N/A	N/A	JOSÉ FÉLIX	JOSÉ FÉLIX	JAVIER MOLINA	JAVIER MOLINA

PART NUMBER	H&T	TREATMENT	FINISH
	N/A	N/A	ASSEMBLY

RELEASED		JOSÉ FÉLIX	
REV. No.	REVISIONS	DATE	BY
		 <p>THIS DRAWING AND INFORMATION CONTAINED HERE ARE EXCLUSIVE PROPERTY OF KUFFERATH AND SHALL BE RETURNED UPON DEMAND AND SHALL NOT BE REPRODUCED IN WHOLE OR IN PARTS.</p>	
		<p>UNLESS OTHERWISE SPECIFIED DIMENSIONS ARE INCH OR [MM]. TOLERANCE: 0.0 = ± .1 0.00 = ± .01 0.000 = ± .001 0.0000 = ± .0005 FRACTIONAL = ± .002 ANGULAR = ± 1° ◆ CRITICAL CHARACTERISTIC</p>	

QT

QTY

1

ITEM NO.	PART NUMBER	DESCRIPTION	QTY.	ITEM NO.	PART NUMBER	DESCRIPTION	QTY.
1	MR-01	BASE Y SISTEMA EJE Z	1	2.2	MR-02-003	SOPORTE PARA BUJE	1
1.1	MR-01-001	BASE INFERIOR	1	2.3	MR-02-002	SOPORTE DE LEAD Y BUJE	1
1.2	MR-01-002	REFUERZO LATERAL	1	2.4	MR-02-004	BUJE PARA LEAD SCREW	2
1.3	MR-01-003	REFUERZO LATERAL DER.	1	2.5	MR-02-005	PURCHASED PART MISUMI PN: MTSR8-200	1
1.4	MR-01-004	BASE DE STEPPER	1	2.6	MR-02-006	PLACA GUIA LEAD SCREW	1
1.5	MR-01-005	PLACA GUIA EJE Z	1	2.7	MR-02-007	BRACKET PARA PALPADOR	1
1.6	MR-01-006	SOPORTE DE FLECHAS	2	2.8	61095K32	BLACK POLYPROPYLENE BALL KNOB	1
1.7	MR-01-007	FLECHAS GUIAS	2	2.9	MR-02-LEAD SCREW NUT	LEAD SCREW NUT	1
1.8	MR-01-008	GUIA DE BALEROS	1	2.10	519-331	MITUTOYO READER	1
1.9	MR-01-009	UNION STEPPER/ LEAD SCREW	1	2.11	519-331-1	-MITUTOYO READER BRACKET	1
1.10	MR-01-012	PLACA SOPORTE EJE Z PARA LVDT	1	2.12	HX-SHCS 0.19-32x0.625x0.625-N	SOCKET HEAD CAP SCREW 10-32	4
1.11	MR-01-015	BASE PRINCIPAL	1	2.13	B18.3.1M - 3 x 0.5 x 8 Hex SHCS -- 8NHX	SOCKET HEAD CAP SCREW M3	2
1.12	MR-01-016	FLECHAS DE SOPORTE	4	2.14	B18.3.1M - 4 x 0.7 x 8 Hex SHCS -- 8NHX	SOCKET HEAD CAP SCREW M4	1
1.13	MR-01-017	TAPA LATERAL	2	3	MR-03	SISTEMA DE CHUCK	1
1.14	MR-01-018	TAPA FRONTAL	1	3.1	MR-03-001	BASE DE CHUCK	1
1.15	57HS2B76-384	STEPPER	1	3.2	MR-03-002	BASE PARA CHUCK	1
1.16	6630K12	Linear Ball Bearings	2	3.3	HX-SHCS 0.5-20x2x2-S	SOCKET HEAD CAP SCREW 1/2-20	1
1.17	97633A230	External Retaining Rings	4	3.4	MR-03-003	ESPACIADOR PARA STEPPER	1
1.18	LEAD SCREW NUT	LEAD SCREW NUT	1	3.5	57HS2B76-384	STEPPER	1
1.19	MTSBR8-160	Lead Screw	1	3.6	self-centering-chuck	CHUCK	1
1.20	LVBM8-20	Leveling Bolts-Standard Type	4	3.6.1	GÖVDE	CHUCK	1
1.21	HX-SHCS 0.25-20x0.5x0.5-C	SOCKET HEAD CAP SCREW 1/4-20	8	3.6.2	konik dişli	CHUCK	1
1.22	B18.3.1M - 5 x 0.8 x 20 Hex SHCS -- 20NHX	SOCKET HEAD CAP SCREW M5	4	3.6.3	arka kapak	CHUCK	1
1.23	B18.3.1M - 5 x 0.8 x 16 Hex SHCS -- 16NHX	SOCKET HEAD CAP SCREW M5	4	3.6.4	okiöo	CHUCK	3
1.24	B18.3.4M - 5 x 0.8 x 16 SBHCS --N	SOCKET HEAD CAP SCREW M5	4	3.6.5	ayak 1	CHUCK	1
1.25	93600A533	dowel pin 5mm x 12mm	4	3.6.6	ayak 2	CHUCK	1
1.26	B18.3.5M - 8 x 1.25 x 16 Socket FCHS -- 16N	flat CAP head SCREW M8	4	3.6.7	ayak 3	CHUCK	1
1.27	SBHCSREW 0.25-20x0.4375-HX-N	SOCKET HEAD CAP SCREW 1/4-20	2	3.7	60355K708	Ball Bearing, Sealed, Trade Number R16-2RS, for 1" Shaft Diameter	1
1.28	B18.3.1M - 3 x 0.5 x 6 Hex SHCS -- 6NHX	SOCKET HEAD CAP SCREW M3	4	3.8	9714K1	WAVE WASHER	1
1.29	HX-SHCS 0.25-20x0.5x0.5-N	SOCKET HEAD CAP SCREW 1/4-20	4	3.9	91078A225	TUERCA DE ACERO	1
1.30	ASME B18.8.2 - 0.2502x0.5	DOWEL PIN Ø1/4X 1/2	4	3.10	HX-SHCS 0.19-32x0.5x0.5-N	SOCKET HEAD CAP SCREW 10-32	4
1.31	90710A037	THIN HEX NUT	4	4	B18.3.1M - 4 x 0.7 x 12 Hex SHCS -- 12NHX	SOCKET HEAD CAP SCREW M4	8
1.32	B18.3.4M - 4 x 0.7 x 8 SBHCS --N	SOCKET HEAD CAP SCREW M4	6				
2	MR-02	SISTEMA DE LVDT	1				
2.1	MR-02-001	RETENEDOR LEAD SCREW	1				

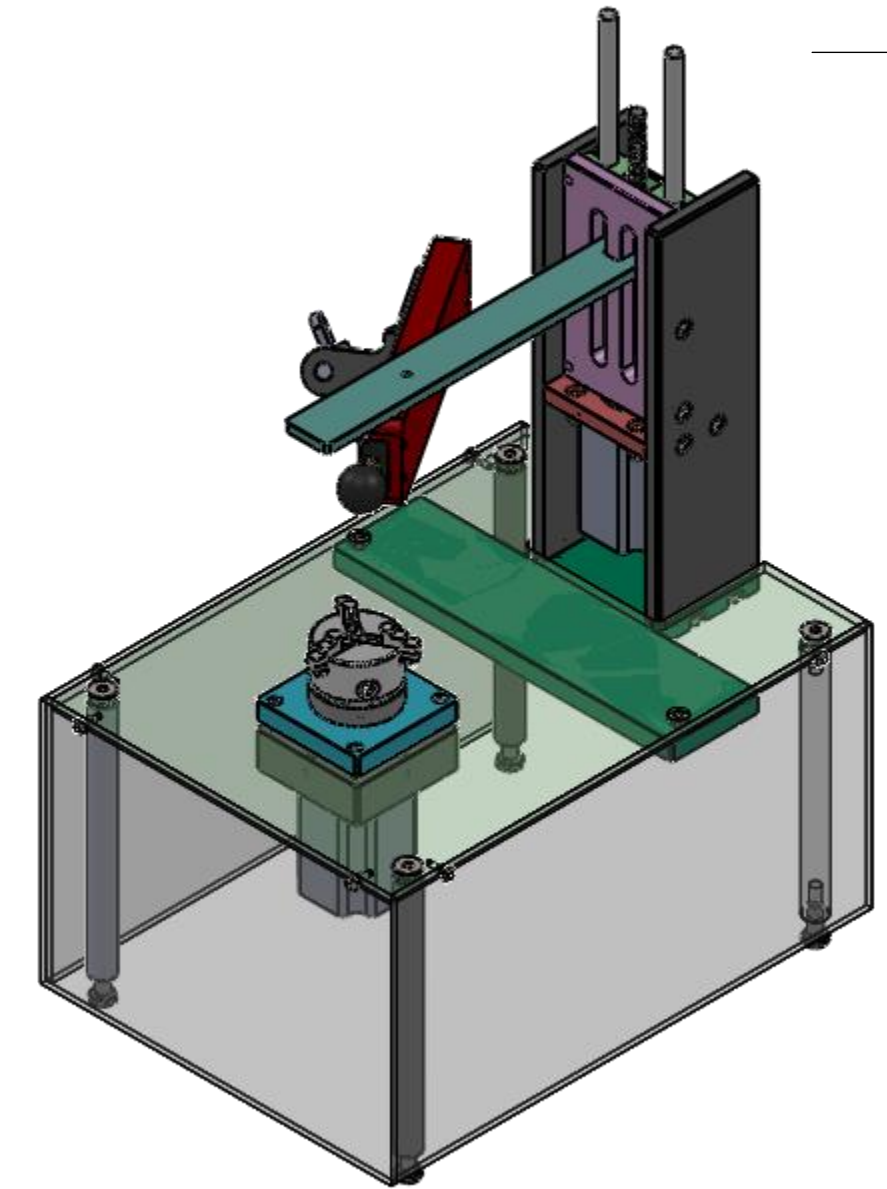



PROJECT	PART NUMBER	H&T	TREATMENT	FINISH					
MR-01		N/A	N/A	ASSEMBLY					
MATERIAL	STOCK SIZE	CYLINDER STOCK SIZE	DESIGNED BY:	DRAWN BY:	APPROVED BY:	REVIEWED BY:			
N/A	THK N/A	W N/A	L N/A	Ø N/A	L N/A	JOSÉ FÉLIX	JOSÉ FÉLIX	JAVIER MOLINA	JAVIER MOLINA

REV. No.	REVISIONS	DATE	BY
			JOSÉ FÉLIX

UNLESS OTHERWISE SPECIFIED DIMENSIONS ARE INCH OR [MM].
 TOLERANCE:
 0.0 = ± .1
 0.00 = ± .01
 0.000 = ± .001
 0.0000 = ± .0005
 FRACTIONAL = ± 1/1000
 ANGULAR = ± 1/4
 ◆ CRITICAL CHARACTERISTIC

QTY

MATERIAL	STOCK SIZE			CYLINDER STOCK SIZE		DESIGNED BY:	DRAWN BY:	APPROVED BY:	REVIEWED BY:
	W	L	Ø	L					
N/A	N/A	N/A	N/A	N/A	N/A	JOSÉ FÉLIX	JOSÉ FÉLIX	JAVIER MOLINA	JAVIER MOLINA

RELEASED		JOSÉ FÉLIX	
REV. No.	REVISIONS	DATE	BY
			
<small>THIS DRAWING AND INFORMATION CONTAINED HERE ARE EXCLUSIVE PROPERTY OF KUFFERATH AND SHALL BE RETURNED UPON DEMAND AND SHALL NOT BE REPRODUCED IN WHOLE OR IN PARTS.</small>			
<small>UNLESS OTHERWISE SPECIFIED DIMENSIONS ARE INCH OR [MM].</small>			
<small>TOLERANCE:</small> 0.0 = ± .1 0.00 = ± .01 0.000 = ± .001 0.0000 = ± .0005 FRACTIONAL = ± .002 ANGULAR = ± 1° ◆ CRITICAL CHARACTERISTIC			
			

19
2

QTY

F

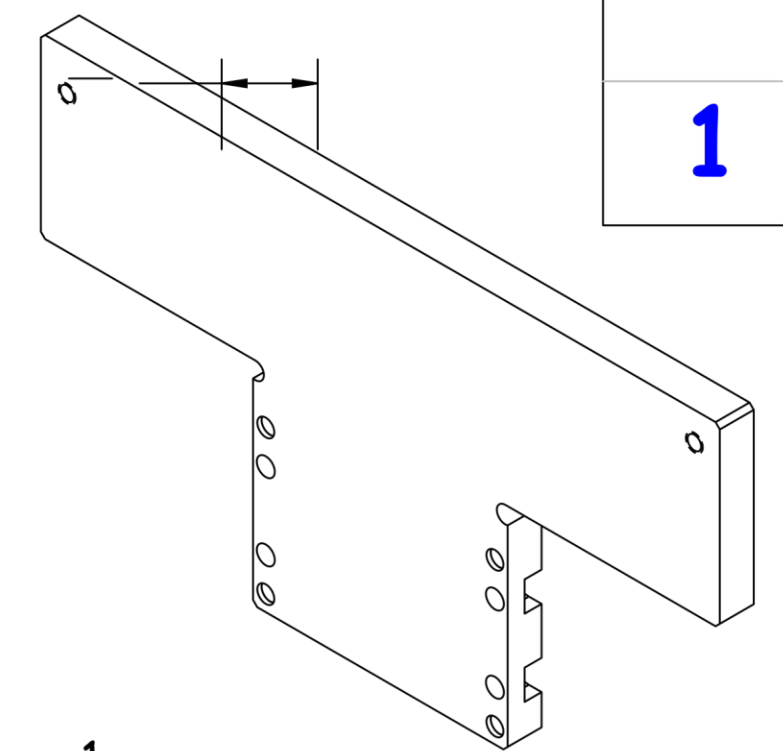
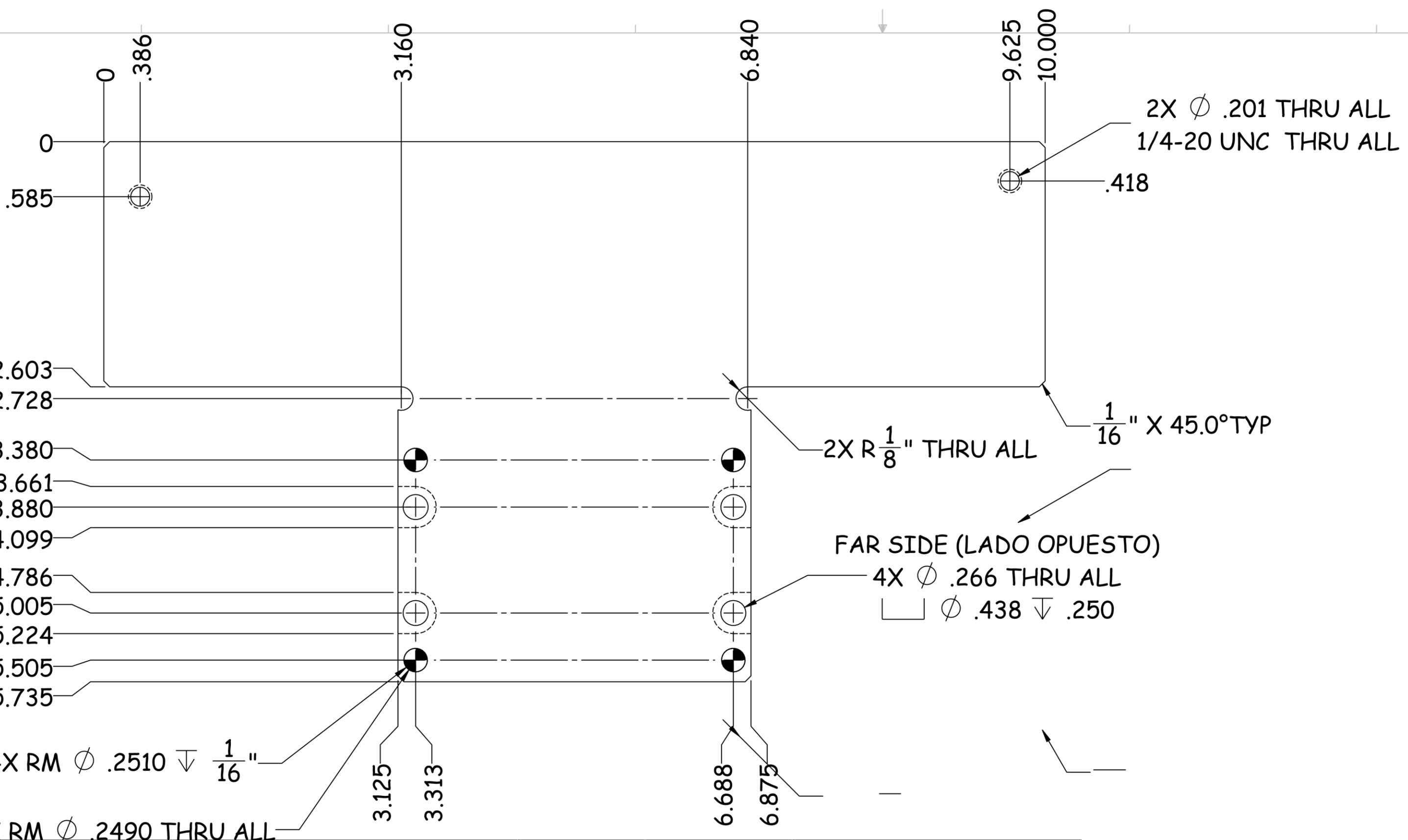

1

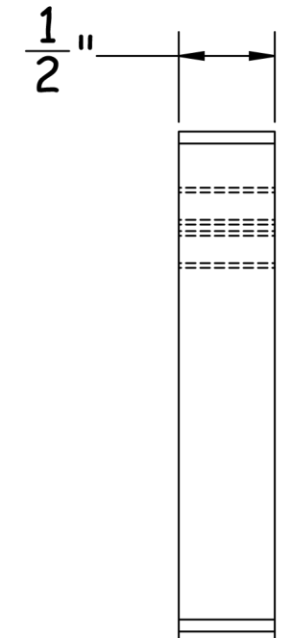

PROJECT	WORK TYPE	H&T	TREATMENT	FINISH		
MR-01	NEW PART	N/A	ANODIZED BLACK	MILLING		
MATERIAL	STOCK SIZE	CYLINDER STOCK SIZE	DESIGNED BY:	DRAWN BY:	APPROVED BY:	REVIEWED BY:
ALUMINUM TOOLING PLATE	10"	N/A N/A	JOSÉ FÉLIX	JOSÉ FÉLIX	JAVIER MOLINA	JAVIER MOLINA
DESCRIPTION		PART NUMBER				

REV. No.		RELEASED	DATE	BY
				JOSÉ FÉLIX
REVISIONS		THIS DRAWING AND INFORMATION CONTAINED HERE ARE EXCLUSIVE PROPERTY OF KUFFERATH AND SHALL BE RETURNED UPON DEMAND AND SHALL NOT BE REPRODUCED IN WHOLE OR IN PARTS.		
		UNLESS OTHERWISE SPECIFIED DIMENSIONS ARE INCH OR [MM]. TOLERANCE: 0.0 = ±.1 0.00 = ±.01 0.000 = ±.001 0.0000 = ±.0005 FRACTIONAL = ±.002 ANGULAR = ± 1° ♦ CRITICAL CHARACTERISTIC		

F

E

D

A

C

8

7

6

5

4

3

2

1

6

5

7

4

6

3

5

3

2

4

1

3

2

4

2

1

QTY

1



PROJECT		WORK TYPE		H&T	TREATMENT	FINISH			
MR-01		NEW PART		N/A	ANODIZED BLACK	MILLING			
MATERIAL	STOCK SIZE		CYLINDER STOCK SIZE		DESIGNED BY:	DRAWN BY:	APPROVED BY:	REVIEWED BY:	
ALUMINUM TOOLING PLATE	THK	L	Ø	L	JOSÉ FÉLIX	JOSÉ FÉLIX	JAVIER MOLINA	JAVIER MOLINA	
	3/8"	10"	N/A	N/A					
6 BASE INFERIOR	5	7	4	6	3	5	2	4	
								1	3

6 BASE INFERIOR

5 7
3/8" 10" N/A N/A
MR-01-001

4 6
JOSÉ FÉLIX JOSÉ FÉLIX JAVIER MOLINA JAVIER MOLINA

3 5
2 4
1 3

	RELEASED		JOSÉ FÉLIX
REV. No.	REVISIONS	DATE	BY
			<small>THIS DRAWING AND INFORMATION CONTAINED HERE ARE EXCLUSIVE PROPERTY OF KUFFERATH AND SHALL BE RETURNED UPON DEMAND AND SHALL NOT BE REPRODUCED IN WHOLE OR IN PARTS.</small>
			



THIS DRAWING AND INFORMATION CONTAINED HERE ARE EXCLUSIVE PROPERTY OF KUFFERATH AND SHALL BE RETURNED UPON DEMAND AND SHALL NOT BE REPRODUCED IN WHOLE OR IN PARTS.



UNLESS OTHERWISE SPECIFIED DIMENSIONS ARE INCH OR [MM]. TOLERANCE:
 0.0 = ± .1
 0.00 = ± .01
 0.000 = ± .001
 0.0000 = ± .0005
 FRACTIONAL = ± .002
 ANGULAR = ± 1°
 ◆ CRITICAL CHARACTERISTIC

2 1

QTY

1

PROJECT		WORK TYPE		H&T	TREATMENT	FINISH		
MR-01		NEW PART		N/A	ANODIZED BLACK	MILLING		
MATERIAL	STOCK SIZE		CYLINDER STOCK SIZE		DESIGNED BY:	DRAWN BY:	APPROVED BY:	REVIEWED BY:
ALUMINUM TOOLING PLATE	THK	L	Ø	L	JOSÉ FÉLIX	JOSÉ FÉLIX	JAVIER MOLINA	JAVIER MOLINA
	3/8"	10"	N/A	N/A				

	RELEASED	JOSÉ FÉLIX
REV. No.	REVISIONS	DATE BY
	 THIRD ANGLE PROJECTION	<small>THIS DRAWING AND INFORMATION CONTAINED HERE ARE EXCLUSIVE PROPERTY OF KUFFERATH AND SHALL BE RETURNED UPON DEMAND AND SHALL NOT BE REPRODUCED IN WHOLE OR IN PARTS.</small>
		<small>UNLESS OTHERWISE SPECIFIED DIMENSIONS ARE INCH OR [MM]. TOLERANCE: 0.0 = ±.1 0.00 = ±.01 0.000 = ±.001 0.0000 = ±.0005 FRACTIONAL = ±.002 ANGULAR = ± 1° ◆ CRITICAL CHARACTERISTIC</small>
		

TITLE 1 3

2

1

8

7

6

5

4

3

2

1

F

F

E

D

C



B

A

QTY

1

PROJECT		WORK TYPE		H&T	TREATMENT	FINISH		
MR-01		NEW PART		N/A	ANODIZED BLACK	MILLING		
MATERIAL	STOCK SIZE		CYLINDER STOCK SIZE		DESIGNED BY:	DRAWN BY:	APPROVED BY:	REVIEWED BY:
ALUMINUM TOOLING PLATE	THK	L	Ø	L	JOSÉ FÉLIX	JOSÉ FÉLIX	JAVIER MOLINA	JAVIER MOLINA
	3/8" THK	10"	N/A	N/A				



	RELEASED		JOSÉ FÉLIX
REV. No.	REVISIONS	DATE	BY
		 THIRD ANGLE PROJECTION	<small>THIS DRAWING AND INFORMATION CONTAINED HERE ARE EXCLUSIVE PROPERTY OF KUFFERATH AND SHALL BE RETURNED UPON DEMAND AND SHALL NOT BE REPRODUCED IN WHOLE OR IN PARTS.</small>
			

QTY

1

PROJECT	WORK TYPE			H&T		TREATMENT	FINISH	
MR-01	NEW PART			N/A		ANODIZED BLACK	MILLING	
MATERIAL	STOCK SIZE		CYLINDER STOCK SIZE		DESIGNED BY:	DRAWN BY:	APPROVED BY:	REVIEWED BY:
ALUMINUM TOOLING PLATE	THK	L	Ø	L	JOSÉ FÉLIX	JOSÉ FÉLIX	JAVIER MOLINA	JAVIER MOLINA
	3/8"	10"	N/A	N/A				



BASE INFERIOR

REV. No.		RELEASED	DATE	BY
				JOSÉ FÉLIX
		 THIRD ANGLE PROJECTION	THIS DRAWING AND INFORMATION CONTAINED HERE ARE EXCLUSIVE PROPERTY OF KUFFERATH AND SHALL BE RETURNED UPON DEMAND AND SHALL NOT BE REPRODUCED IN WHOLE OR IN PARTS.	
		UNLESS OTHERWISE SPECIFIED DIMENSIONS ARE INCH OR [MM]. TOLERANCE: 0.0 = ± .1 0.00 = ± .01 0.000 = ± .001 0.0000 = ± .0005 FRACTIONAL = ± .002 ANGULAR = ± 1° ◆ CRITICAL CHARACTERISTIC		

QTY

1

PROJECT		WORK TYPE		H&T	TREATMENT	FINISH		
MR-01		NEW PART		N/A	ANODIZED BLACK	MILLING		
MATERIAL	STOCK SIZE		CYLINDER STOCK SIZE		DESIGNED BY:	DRAWN BY:	APPROVED BY:	REVIEWED BY:
ALUMINUM TOOLING PLATE	THK	L	Ø	L	JOSÉ FÉLIX	JOSÉ FÉLIX	JAVIER MOLINA	JAVIER MOLINA
	3/8"	10"	N/A	N/A				
	1/2"	5 3/4"						

RELEASED		JOSÉ FÉLIX
REV. No.	REVISIONS	DATE BY
		 <p>THIS DRAWING AND INFORMATION CONTAINED HERE ARE EXCLUSIVE PROPERTY OF KUFFERATH AND SHALL BE RETURNED UPON DEMAND AND SHALL NOT BE REPRODUCED IN WHOLE OR IN PARTS.</p> <p>UNLESS OTHERWISE SPECIFIED DIMENSIONS ARE INCH OR [MM]. TOLERANCE: 0.0 = ± .1 0.00 = ± .01 0.000 = ± .001 0.0000 = ± .0005 FRACTIONAL = ± .002 ANGULAR = ± 1° ◆ CRITICAL CHARACTERISTIC</p>
		

QTY

1

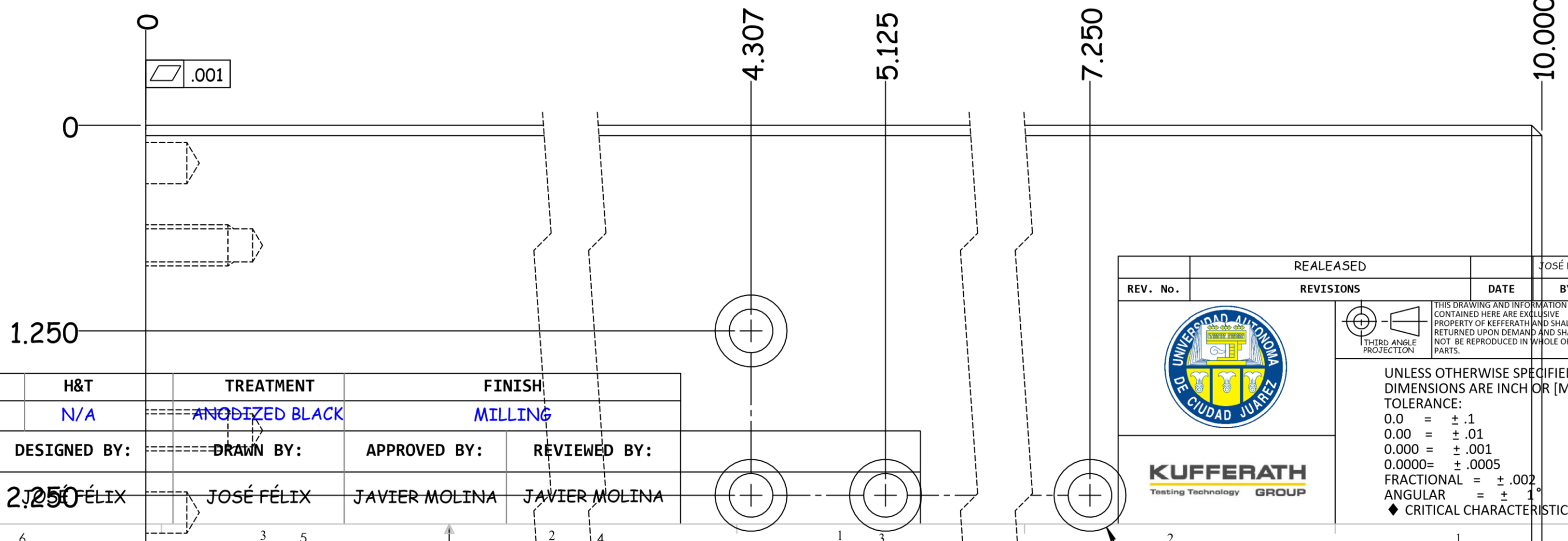
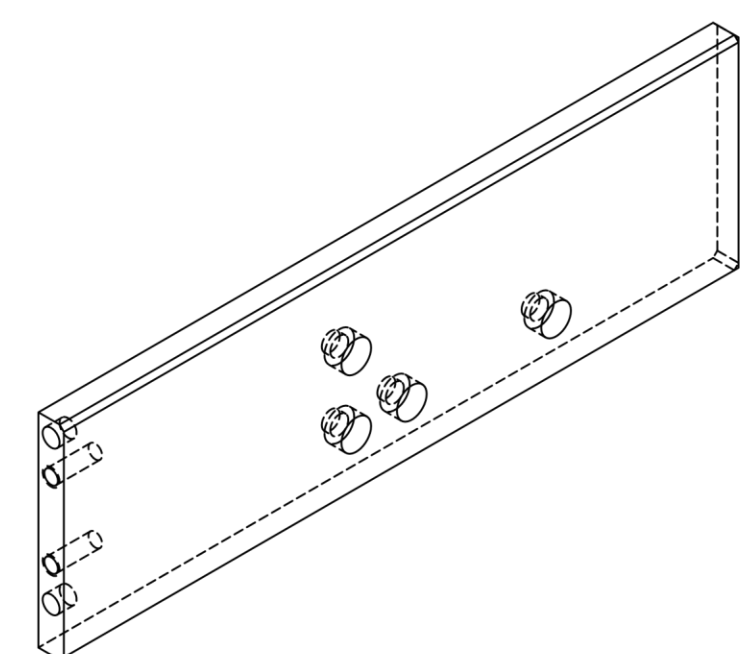
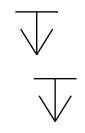
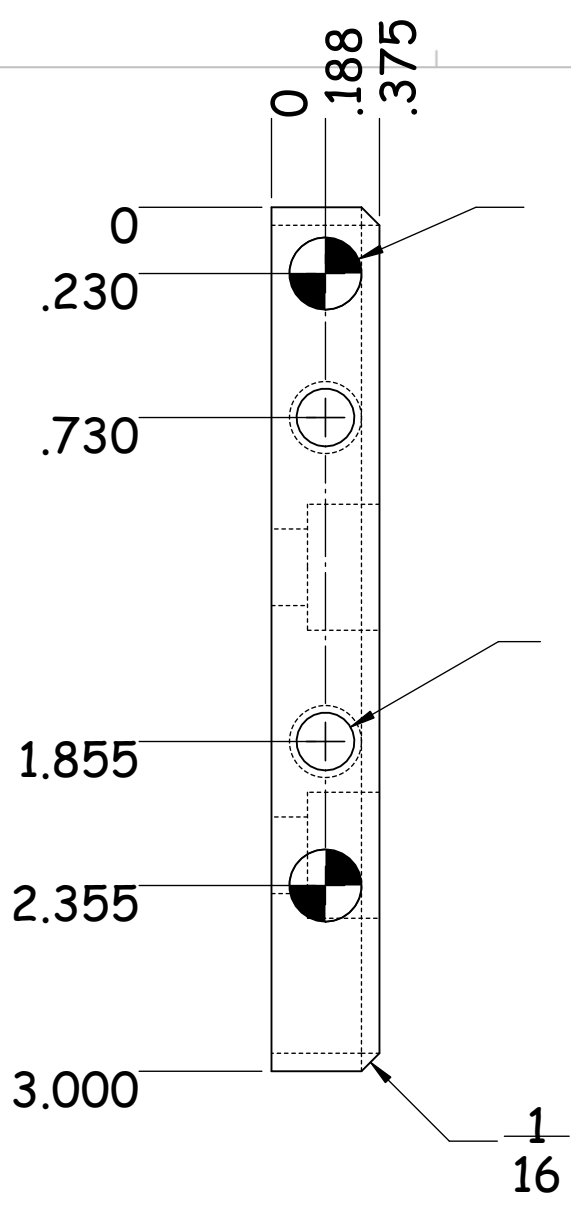

PROJECT	MR-01	WORK TYPE	NEW PART	H&T	N/A	TREATMENT	ANODIZED BLACK	FINISH	MILLING					
MATERIAL	ALUMINUM TOOLING PLATE	STOCK SIZE	THK 3/8"	L 10"	Ø N/A	L N/A	DESIGNED BY:	2.250 FÉLIX	DRAWN BY:	JOSÉ FÉLIX	APPROVED BY:	JAVIER MOLINA	REVIEWED BY:	JAVIER MOLINA
		2X RM		Ø	.2510									

UNIVERSIDAD AUTÓNOMA DE CIUDAD JUÁREZ		KUFFERATH Testing Technology GROUP	
REV. No.	REVISIONS	DATE	BY
			JOSÉ FÉLIX



THIRD ANGLE PROJECTION

UNLESS OTHERWISE SPECIFIED DIMENSIONS ARE INCH OR [MM].
 TOLERANCE:
 0.0 = ± .1
 0.00 = ± .01
 0.000 = ± .001
 0.0000 = ± .0005
 FRACTIONAL = ± .002
 ANGULAR = ± 1°
 ♦ CRITICAL CHARACTERISTIC

QTY

1

PROJECT		WORK TYPE		H&T	TREATMENT	FINISH		
MR-01		NEW PART		N/A	ANODIZED BLACK	MILLING		
MATERIAL	STOCK SIZE		CYLINDER STOCK SIZE		DESIGNED BY:	DRAWN BY:	APPROVED BY:	REVIEWED BY:
ALUMINUM TOOLING PLATE	THK	L	Ø	L	JOSÉ FÉLIX	JOSÉ FÉLIX	JAVIER MOLINA	JAVIER MOLINA
	3/8"	10"	N/A	N/A				

	RELEASED	JOSÉ FÉLIX
REV. No.	REVISIONS	DATE BY
		 <p>THIS DRAWING AND INFORMATION CONTAINED HERE ARE EXCLUSIVE PROPERTY OF KUFFERATH AND SHALL BE RETURNED UPON DEMAND AND SHALL NOT BE REPRODUCED IN WHOLE OR IN PARTS.</p> <p>UNLESS OTHERWISE SPECIFIED DIMENSIONS ARE INCH OR [MM]. TOLERANCE: 0.0 = ± .1 0.00 = ± .01 0.000 = ± .001 0.0000 = ± .0005 FRACTIONAL = ± .002 ANGULAR = ± 1° ◆ CRITICAL CHARACTERISTIC</p>
		

QTY

1

PROJECT		WORK TYPE		H&T	TREATMENT	FINISH		
MR-01		NEW PART		N/A	ANODIZED BLACK	MILLING		
MATERIAL	STOCK SIZE		CYLINDER STOCK SIZE		DESIGNED BY:	DRAWN BY:	APPROVED BY:	REVIEWED BY:
ALUMINUM TOOLING PLATE	THK	L	Ø	L	JOSÉ FÉLIX	JOSÉ FÉLIX	JAVIER MOLINA	JAVIER MOLINA
	3/8"	10"	N/A	N/A				

	RELEASED		JOSÉ FÉLIX
REV. No.	REVISIONS	DATE	BY



THIS DRAWING AND INFORMATION CONTAINED HERE ARE EXCLUSIVE PROPERTY OF KUFFERATH AND SHALL BE RETURNED UPON DEMAND AND SHALL NOT BE REPRODUCED IN WHOLE OR IN PARTS.

UNLESS OTHERWISE SPECIFIED DIMENSIONS ARE INCH OR [MM].
 TOLERANCE:
 0.0 = ± .1
 0.00 = ± .01
 0.000 = ± .001
 0.0000 = ± .0005
 FRACTIONAL = ± .002
 ANGULAR = ± 1°
 ◆ CRITICAL CHARACTERISTIC

QTY



1

PROJECT	WORK TYPE	H&T	TREATMENT	FINISH								
MR-01	NEW PART	N/A	ANODIZED BLACK	MILLING								
MATERIAL	STOCK SIZE	CYLINDER STOCK SIZE	DESIGNED BY:	DRAWN BY:	APPROVED BY:	REVIEWED BY:						
ALUMINUM TOOLING PLATE	THK 3/8"	L 10"	Ø N/A	L N/A	JOSÉ FÉLIX	JOSÉ FÉLIX	JAVIER MOLINA	JAVIER MOLINA				
6	2X Ø .201	.650	1/4-20 UNC	.500	4	6	3	5	2	4	1	3

REV. No.	REVISIONS	DATE	BY
			JOSÉ FÉLIX
		 <p>THIS DRAWING AND INFORMATION CONTAINED HERE ARE EXCLUSIVE PROPERTY OF KUFFERATH AND SHALL BE RETURNED UPON DEMAND AND SHALL NOT BE REPRODUCED IN WHOLE OR IN PARTS.</p>	
		<p>UNLESS OTHERWISE SPECIFIED DIMENSIONS ARE INCH OR [MM]. TOLERANCE: 0.0 = ± .1 0.00 = ± .01 0.000 = ± .001 0.0000 = ± .0005 FRACTIONAL = ± .002 ANGULAR = ± 1° ◆ CRITICAL CHARACTERISTIC</p>	

QTY

1

REV. No.		RELEASED		DATE		BY	
		REVISIONS				JOSÉ FÉLIX	
		 THIRD ANGLE PROJECTION		<small>THIS DRAWING AND INFORMATION CONTAINED HERE ARE EXCLUSIVE PROPERTY OF KUFFERATH AND SHALL BE RETURNED UPON DEMAND AND SHALL NOT BE REPRODUCED IN WHOLE OR IN PARTS.</small>			
				<small>UNLESS OTHERWISE SPECIFIED DIMENSIONS ARE INCH OR [MM]. TOLERANCE: 0.0 = ±.1 0.00 = ±.01 0.000 = ±.001 0.0000 = ±.0005 FRACTIONAL = ±.002 ANGULAR = ± 1° ◆ CRITICAL CHARACTERISTIC</small>			
							



PROJECT	WORK TYPE	H&T	TREATMENT	FINISH	
MR-01	NEW PART	N/A	ANODIZED BLACK	MILLING	
MATERIAL	STOCK SIZE	DESIGNED BY:	DRAWN BY:	APPROVED BY:	REVIEWED BY:
ALUMINUM TOOLING PLATE	THK	JOSÉ FÉLIX	JOSÉ FÉLIX	JAVIER MOLINA	JAVIER MOLINA
	3/8"				

"5 X 45.0° TYP

QTY

1



PROJECT		WORK TYPE		H&T	TREATMENT	FINISH		
MR-01		NEW PART		N/A	ANODIZED BLACK	MILLING		
MATERIAL	STOCK SIZE		CYLINDER STOCK SIZE		DESIGNED BY:	DRAWN BY:	APPROVED BY:	REVIEWED BY:
	THK	L	Ø	L				
ALUMINUM TOOLING PLATE	3/8"	10"	N/A	N/A	JOSÉ FÉLIX	JOSÉ FÉLIX	JAVIER MOLINA	JAVIER MOLINA
DESCRIPTION	PART NUMBER	REFUERZO LATERAL MR-01-002						

	RELEASED		JOSÉ FÉLIX
REV. No.	REVISIONS	DATE	BY
		 <p>THIS DRAWING AND INFORMATION CONTAINED HERE ARE EXCLUSIVE PROPERTY OF KUFFERATH AND SHALL BE RETURNED UPON DEMAND AND SHALL NOT BE REPRODUCED IN WHOLE OR IN PARTS.</p>	
		<p>UNLESS OTHERWISE SPECIFIED DIMENSIONS ARE INCH OR [MM]. TOLERANCE: 0.0 = ± .1 0.00 = ± .01 0.000 = ± .001 0.0000 = ± .0005 FRACTIONAL = ± .002 ANGULAR = ± 1° ◆ CRITICAL CHARACTERISTIC</p>	

QTY

1



PROJECT		WORK TYPE		H&T	TREATMENT	FINISH		
MR-01		NEW PART		N/A	ANODIZED BLACK	MILLING		
MATERIAL	STOCK SIZE		CYLINDER STOCK SIZE		DESIGNED BY:	DRAWN BY:	APPROVED BY:	REVIEWED BY:
ALUMINUM TOOLING PLATE	THK 3/8"	L 10"	Ø N/A	L N/A	JOSÉ FÉLIX	JOSÉ FÉLIX	JAVIER MOLINA	JAVIER MOLINA

	RELEASED		JOSÉ FÉLIX
REV. No.	REVISIONS	DATE	BY
		 THIRD ANGLE PROJECTION	
		<small>THIS DRAWING AND INFORMATION CONTAINED HERE ARE EXCLUSIVE PROPERTY OF KUFFERATH AND SHALL BE RETURNED UPON DEMAND AND SHALL NOT BE REPRODUCED IN WHOLE OR IN PARTS.</small>	
		<small>UNLESS OTHERWISE SPECIFIED DIMENSIONS ARE INCH OR [MM].</small> <small>TOLERANCE:</small> <small>0.0 = ± .1</small> <small>0.00 = ± .01</small> <small>0.000 = ± .001</small> <small>0.0000 = ± .0005</small> <small>FRACTIONAL = ± .002</small> <small>ANGULAR = ± 1°</small> <small>◆ CRITICAL CHARACTERISTIC</small>	

QTY

1

PROJECT		WORK TYPE		H&T	TREATMENT	FINISH		
MR-01		NEW PART		N/A	ANODIZED BLACK	MILLING		
MATERIAL	STOCK SIZE		CYLINDER STOCK SIZE		DESIGNED BY:	DRAWN BY:	APPROVED BY:	REVIEWED BY:
ALUMINUM TOOLING PLATE	THK	L	Ø	L	JOSÉ FÉLIX	JOSÉ FÉLIX	JAVIER MOLINA	JAVIER MOLINA
	3/8"	3"	10"	N/A N/A				

	RELEASED	JOSÉ FÉLIX
REV. No.	REVISIONS	DATE BY
		 <p>THIS DRAWING AND INFORMATION CONTAINED HERE ARE EXCLUSIVE PROPERTY OF KUFFERATH AND SHALL BE RETURNED UPON DEMAND AND SHALL NOT BE REPRODUCED IN WHOLE OR IN PARTS.</p> <p>UNLESS OTHERWISE SPECIFIED DIMENSIONS ARE INCH OR [MM]. TOLERANCE: 0.0 = ± .1 0.00 = ± .01 0.000 = ± .001 0.0000 = ± .0005 FRACTIONAL = ± .002 ANGULAR = ± 1° ◆ CRITICAL CHARACTERISTIC</p>
		

QTY

1

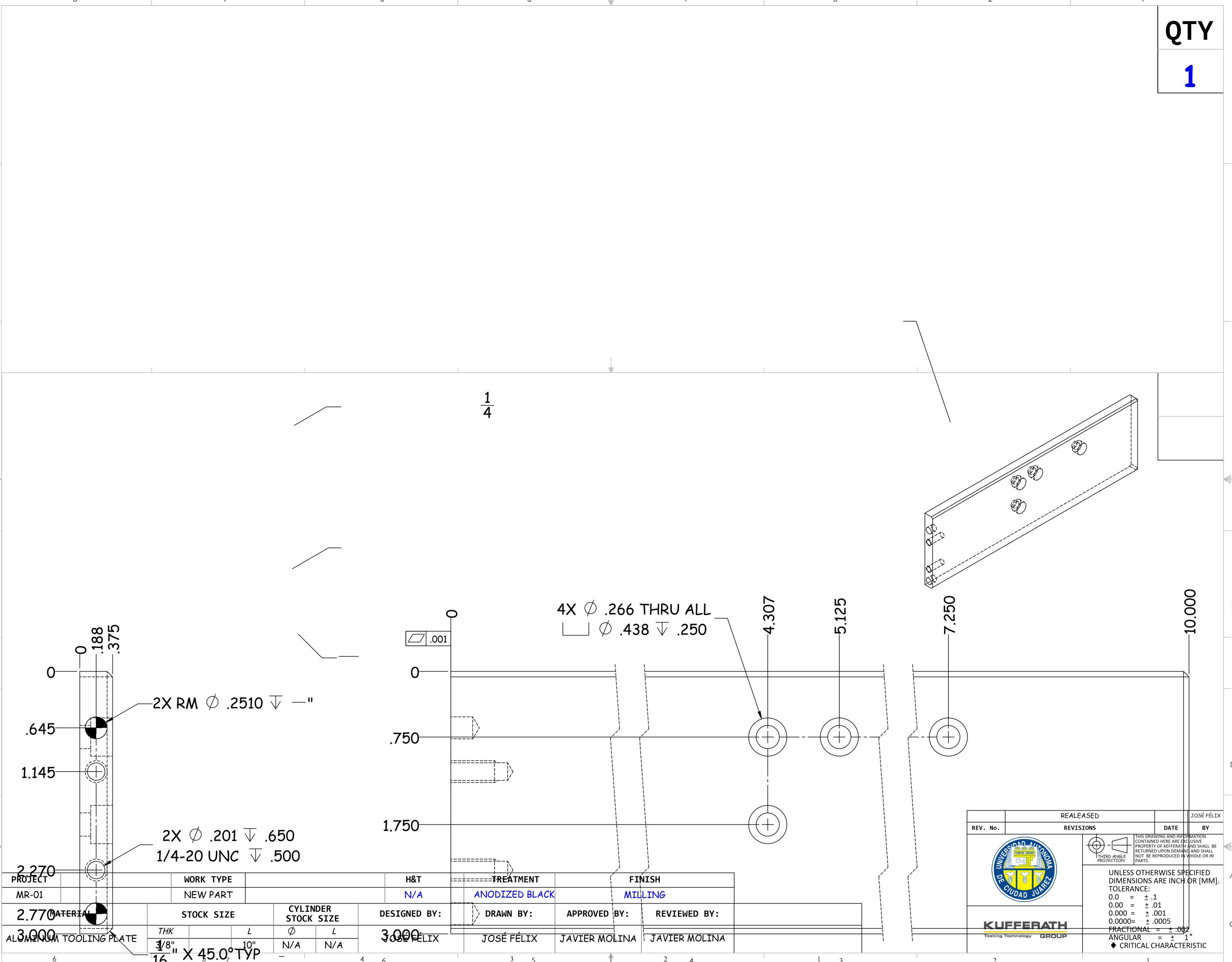

PROJECT	MR-01	WORK TYPE	NEW PART	H&T	N/A	TREATMENT	ANODIZED BLACK	FINISH	MILLING	
MATERIAL	ALUMINUM TOOLING PLATE	STOCK SIZE	THK 3/8" 16" X 45.0° TYP	L 10"	Ø N/A	L N/A	DESIGNED BY:	DRAWN BY:	APPROVED BY:	REVIEWED BY:
QUANTITY	3,000						JOSÉ FÉLIX	JOSÉ FÉLIX	JAVIER MOLINA	JAVIER MOLINA

REV. No.		REVISIONS		DATE	BY
					JOSÉ FÉLIX
		THIS DRAWING AND INFORMATION CONTAINED HERE ARE EXCLUSIVE PROPERTY OF KUFFERATH AND SHALL BE RETURNED UPON DEMAND AND SHALL NOT BE REPRODUCED IN WHOLE OR IN PARTS.			
		UNLESS OTHERWISE SPECIFIED DIMENSIONS ARE INCH OR [MM]. TOLERANCE: 0.0 = ± .1 0.00 = ± .01 0.000 = ± .001 0.0000 = ± .0005 FRACTIONAL = ± .002 ANGULAR = ± 1° ◆ CRITICAL CHARACTERISTIC			
KUFFERATH		Testing Technology		GROUP	

QTY

1

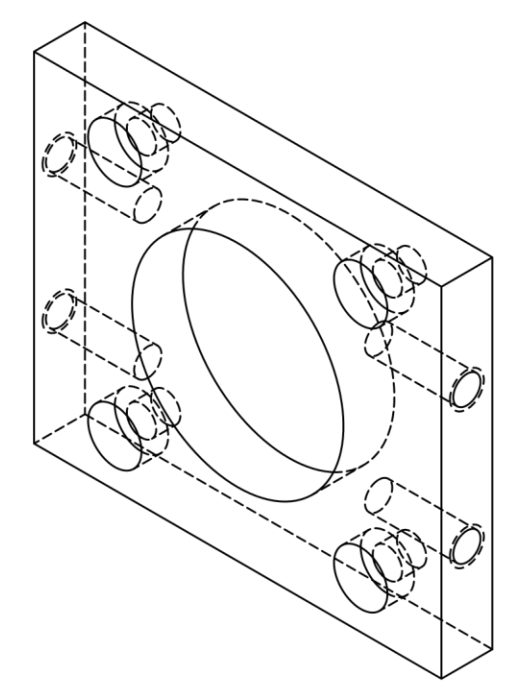
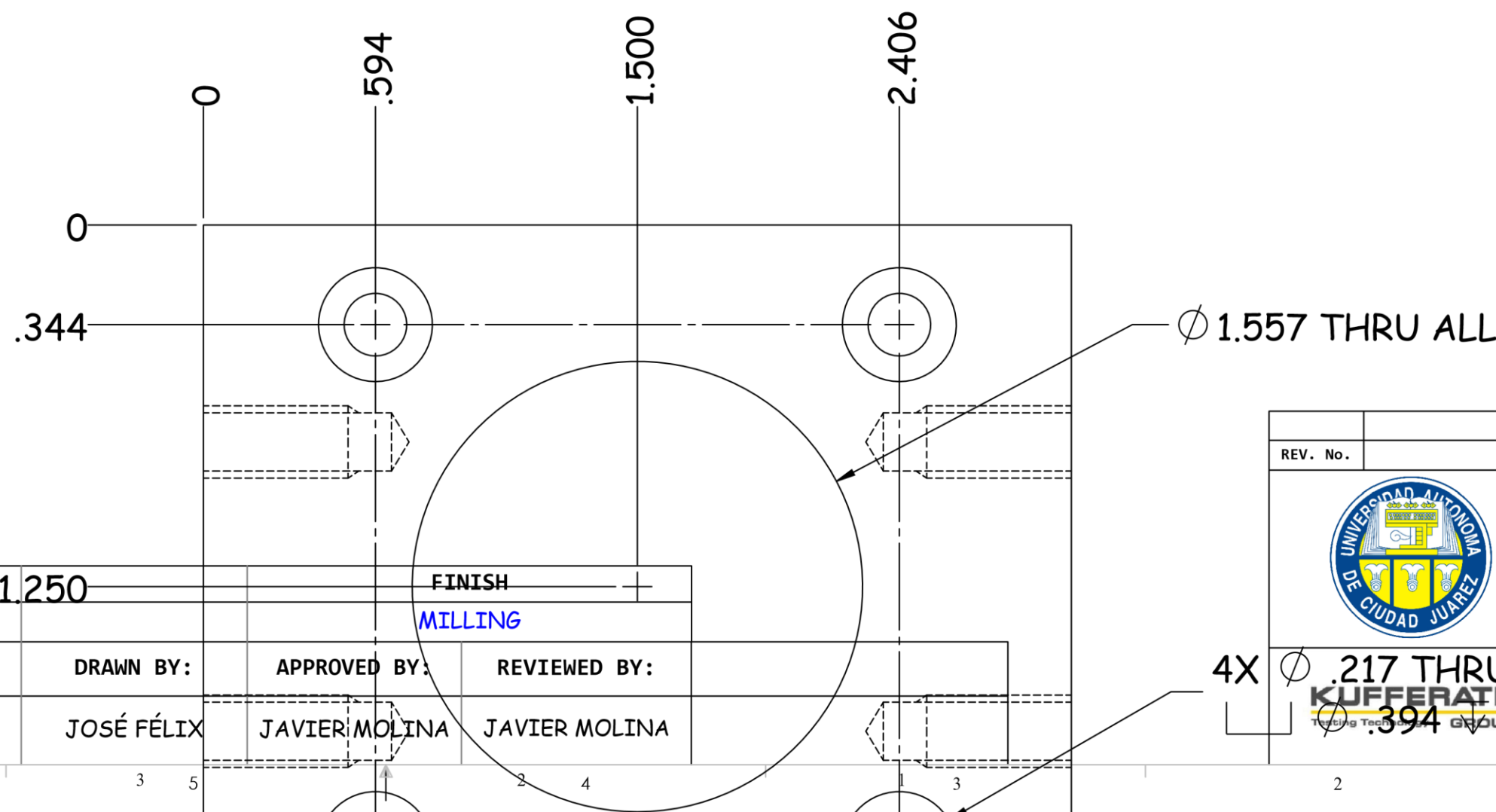
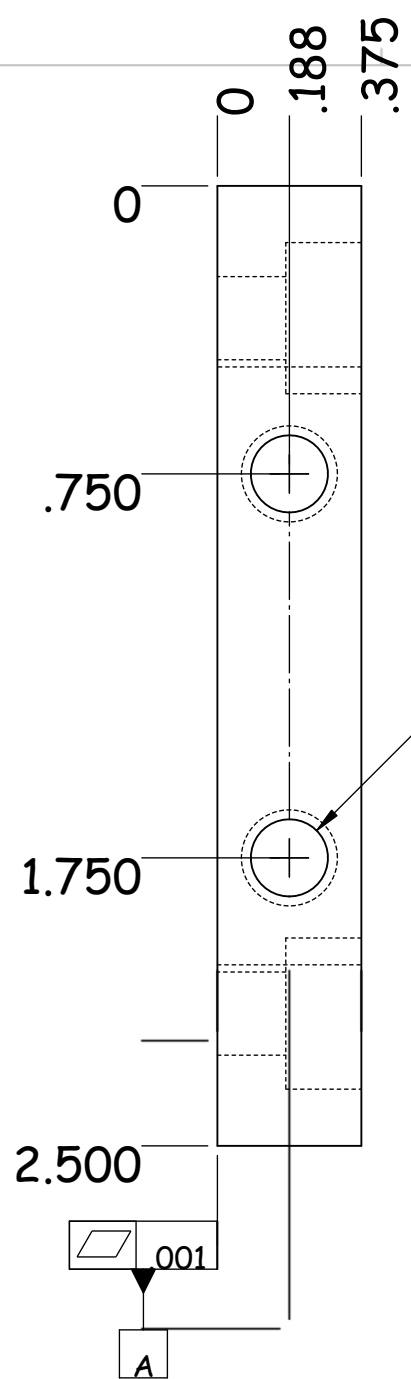

PROJECT	MR-01	WORK TYPE	NEW PART	H&T	1.250	FINISH	MILLING
MATERIAL	ALUMINUM TOOLING PLATE	STOCK SIZE	THK 3/8"	DESIGNED BY:	JOSÉ FÉLIX	DRAWN BY:	JOSÉ FÉLIX
			L 3"	APPROVED BY:	JAVIER MOLINA	REVIEWED BY:	JAVIER MOLINA
		CYLINDER STOCK SIZE	Ø N/A				
			L N/A				

BOTH SIDES (AMBOS LADOS)

REV. No.	REVISIONS	DATE	BY
		01/11/2018	JOSÉ FÉLIX



UNLESS OTHERWISE SPECIFIED DIMENSIONS ARE INCH OR [MM].
 TOLERANCE:
 0.0 = ± .1
 0.00 = ± .01
 0.000 = ± .001
 0.0000 = ± .0005
 FRACTIONAL = ± .002
 ANGULAR = ± 1°
 ◆ CRITICAL CHARACTERISTIC

UNIVERSIDAD AUTÓNOMA DE CIUDAD JUÁREZ

KUFFERATH GROUP



QTY

PROJECT	WORK TYPE	H&T	FINISH
MR-01	NEW PART	N/A	MILLING
MATERIAL	STOCK SIZE	CYLINDER STOCK SIZE	DESIGNED BY:
ALUMINUM TOOLING PLATE	3" L	N/A	JOSÉ FÉLIX
	4X \varnothing .201	N/A	JOSÉ FÉLIX
		.650	JAVIER MOLINA
			JAVIER MOLINA

REV. No.	REVISIONS	DATE	BY
		01/11/2018	JOSÉ FÉLIX
		 <p>THIS DRAWING AND INFORMATION CONTAINED HERE ARE EXCLUSIVE PROPERTY OF KUFFERATH AND SHALL BE RETURNED UPON DEMAND AND SHALL NOT BE REPRODUCED IN WHOLE OR IN PARTS.</p>	
		<p>UNLESS OTHERWISE SPECIFIED DIMENSIONS ARE INCH OR [MM]. TOLERANCE: 0.0 = ± .1 0.00 = ± .01 0.000 = ± .001 0.0000 = ± .0005 FRACTIONAL = ± .002 ANGULAR = ± 1° ◆ CRITICAL CHARACTERISTIC</p>	

QTY

1



REV. No.		BY	JOSÉ FÉLIX
		 <p>THIS DRAWING AND INFORMATION CONTAINED HERE ARE EXCLUSIVE PROPERTY OF KUFFERATH AND SHALL BE RETURNED UPON DEMAND AND SHALL NOT BE REPRODUCED IN WHOLE OR IN PARTS.</p>	
		<p>UNLESS OTHERWISE SPECIFIED DIMENSIONS ARE INCH OR [MM]. TOLERANCE: 0.0 = ± .1 0.00 = ± .01 0.000 = ± .001 0.0000 = ± .0005 FRACTIONAL = ± .002 ANGULAR = ± 1° ◆ CRITICAL CHARACTERISTIC</p>	

PROJECT		WORK TYPE		H&T		FINISH		
MR-01		NEW PART		N/A		MILLING		
MATERIAL	STOCK SIZE		CYLINDER STOCK SIZE		DESIGNED BY:	DRAWN BY:	APPROVED BY:	REVIEWED BY:
ALUMINUM TOOLING PLATE	THK		∅	L	JOSÉ FÉLIX	JOSÉ FÉLIX	JAVIER MOLINA	JAVIER MOLINA
	3/8"		N/A	N/A				

1/4-20 UNC .500⁴

QTY



PROJECT	WORK TYPE	CYLINDER STOCK SIZE		H&T	FINISH			
MR-01	NEW PART	L	Ø	N/A	MILLING			
MATERIAL	STOCK SIZE	L	Ø	DESIGNED BY:	DRAWN BY:	APPROVED BY:	REVIEWED BY:	
ALUMINUM TOOLING PLATE	3"	N/A	N/A	JOSÉ FÉLIX	JOSÉ FÉLIX	JAVIER MOLINA	JAVIER MOLINA	
DESCRIPTION		PART NUMBER		TREATMENT				

REV. No.	REVISIONS	RELEASED	DATE	BY
			01/11/2018	JOSÉ FÉLIX
				
		<small>THIS DRAWING AND INFORMATION CONTAINED HERE ARE EXCLUSIVE PROPERTY OF KUFFERATH AND SHALL BE RETURNED UPON DEMAND AND SHALL NOT BE REPRODUCED IN WHOLE OR IN PARTS.</small>		
		<small>UNLESS OTHERWISE SPECIFIED DIMENSIONS ARE INCH OR [MM].</small> <small>TOLERANCE:</small> <small>0.0 = ± .1</small> <small>0.00 = ± .01</small> <small>0.000 = ± .001</small> <small>0.0000 = ± .0005</small> <small>FRACTIONAL = ± .002</small> <small>ANGULAR = ± 1°</small> <small>◆ CRITICAL CHARACTERISTIC</small>		

QTY



1

PROJECT		WORK TYPE		H&T		FINISH		
MR-01		NEW PART		N/A		MILLING		
MATERIAL	STOCK SIZE		CYLINDER STOCK SIZE		DESIGNED BY:	DRAWN BY:	APPROVED BY:	REVIEWED BY:
ALUMINUM TOOLING PLATE	THK		Ø	L	JOSÉ FÉLIX	JOSÉ FÉLIX	JAVIER MOLINA	JAVIER MOLINA
	3/8"		N/A	N/A				
6 BASE DE STEPPER 5 7 - MR-01-004 4 6 3 5 2 4 1 3								

REV. No.		BY	JOSÉ FÉLIX
			<small>THIS DRAWING AND INFORMATION CONTAINED HERE ARE EXCLUSIVE PROPERTY OF KUFFERATH AND SHALL BE RETURNED UPON DEMAND AND SHALL NOT BE REPRODUCED IN WHOLE OR IN PARTS.</small>
		<small>UNLESS OTHERWISE SPECIFIED DIMENSIONS ARE INCH OR [MM]. TOLERANCE: 0.0 = ±.1 0.00 = ±.01 0.000 = ±.001 0.0000 = ±.0005 FRACTIONAL = ±.002 ANGULAR = ± 1° ◆ CRITICAL CHARACTERISTIC</small>	

QTY

PROJECT		WORK TYPE		H&T		FINISH		
MR-01		NEW PART		N/A		MILLING		
MATERIAL	STOCK SIZE		CYLINDER STOCK SIZE		DESIGNED BY:	DRAWN BY:	APPROVED BY:	REVIEWED BY:
ALUMINUM TOOLING PLATE		L 3"	Ø N/A	L N/A	JOSÉ FÉLIX	JOSÉ FÉLIX	JAVIER MOLINA	JAVIER MOLINA

RELEASED		011/11/2018	JOSÉ FÉLIX
REV. No.	REVISIONS	DATE	BY
		 <small>THIS DRAWING AND INFORMATION CONTAINED HERE ARE EXCLUSIVE PROPERTY OF KUFFERATH AND SHALL BE RETURNED UPON DEMAND AND SHALL NOT BE REPRODUCED IN WHOLE OR IN PARTS.</small>	
		<small>UNLESS OTHERWISE SPECIFIED DIMENSIONS ARE INCH OR [MM].</small> <small>TOLERANCE:</small> <small>0.0 = ± .1</small> <small>0.00 = ± .01</small> <small>0.000 = ± .001</small> <small>0.0000 = ± .0005</small> <small>FRACTIONAL = ± .002</small> <small>ANGULAR = ± 1°</small> <small>◆ CRITICAL CHARACTERISTIC</small>	

TITLE 1 3

2

1



F

F

A



QTY
1

PROJECT		WORK TYPE		H&T		FINISH		
MR-01		NEW PART		N/A		MILLING		
MATERIAL	STOCK SIZE		CYLINDER STOCK SIZE		DESIGNED BY:	DRAWN BY:	APPROVED BY:	REVIEWED BY:
ALUMINUM TOOLING PLATE	<i>THK</i>		\varnothing	<i>L</i>	JOSÉ FÉLIX	JOSÉ FÉLIX	JAVIER MOLINA	JAVIER MOLINA
	3/8"		N/A	N/A				

REV. No.		BY	JOSÉ FÉLIX
		 <p>THIS DRAWING AND INFORMATION CONTAINED HERE ARE EXCLUSIVE PROPERTY OF KUFFERATH AND SHALL BE RETURNED UPON DEMAND AND SHALL NOT BE REPRODUCED IN WHOLE OR IN PARTS.</p>	
		<p>UNLESS OTHERWISE SPECIFIED DIMENSIONS ARE INCH OR [MM]. TOLERANCE: 0.0 = ± .1 0.00 = ± .01 0.000 = ± .001 0.0000 = ± .0005 FRACTIONAL = ± .002 ANGULAR = ± 1° ◆ CRITICAL CHARACTERISTIC</p>	

QTY



PROJECT	WORK TYPE	H&T			FINISH			
MR-01	NEW PART	N/A			MILLING			
MATERIAL	STOCK SIZE		CYLINDER STOCK SIZE		DESIGNED BY:	DRAWN BY:	APPROVED BY:	REVIEWED BY:
ALUMINUM TOOLING PLATE		L	∅	L	JOSÉ FÉLIX	JOSÉ FÉLIX	JAVIER MOLINA	JAVIER MOLINA
		3"	N/A	N/A				

RELEASED		011/11/2018	JOSÉ FÉLIX
REV. No.	REVISIONS	DATE	BY
		 <small>THIS DRAWING AND INFORMATION CONTAINED HERE ARE EXCLUSIVE PROPERTY OF KUFFERATH AND SHALL BE RETURNED UPON DEMAND AND SHALL NOT BE REPRODUCED IN WHOLE OR IN PARTS.</small>	
		<small>UNLESS OTHERWISE SPECIFIED DIMENSIONS ARE INCH OR [MM].</small> <small>TOLERANCE:</small> <small>0.0 = ± .1</small> <small>0.00 = ± .01</small> <small>0.000 = ± .001</small> <small>0.0000 = ± .0005</small> <small>FRACTIONAL = ± .002</small> <small>ANGULAR = ± 1°</small> <small>◆ CRITICAL CHARACTERISTIC</small>	
			

MR-01-004

QTY

1

REV. No.		BY	JOSÉ FÉLIX
		 THIRD ANGLE PROJECTION	<small>THIS DRAWING AND INFORMATION CONTAINED HERE ARE EXCLUSIVE PROPERTY OF KUFFERATH AND SHALL BE RETURNED UPON DEMAND AND SHALL NOT BE REPRODUCED IN WHOLE OR IN PARTS.</small>
		<small>UNLESS OTHERWISE SPECIFIED DIMENSIONS ARE INCH OR [MM]. TOLERANCE: 0.0 = ± .1 0.00 = ± .01 0.000 = ± .001 0.0000 = ± .0005 FRACTIONAL = ± .002 ANGULAR = ± 1° ◆ CRITICAL CHARACTERISTIC</small>	

PROJECT		WORK TYPE		H&T		FINISH		
MR-01		NEW PART		N/A		MILLING		
MATERIAL	STOCK SIZE		CYLINDER STOCK SIZE		DESIGNED BY:	DRAWN BY:	APPROVED BY:	REVIEWED BY:
ALUMINUM TOOLING PLATE	THK		∅	L	JOSÉ FÉLIX	JOSÉ FÉLIX	JAVIER MOLINA	JAVIER MOLINA
	3/8"	2 1/2"	N/A	N/A				

QTY

$\frac{1}{32}$

" X 45.0° TYP

2X SLOT ϕ .440
THRU ALL

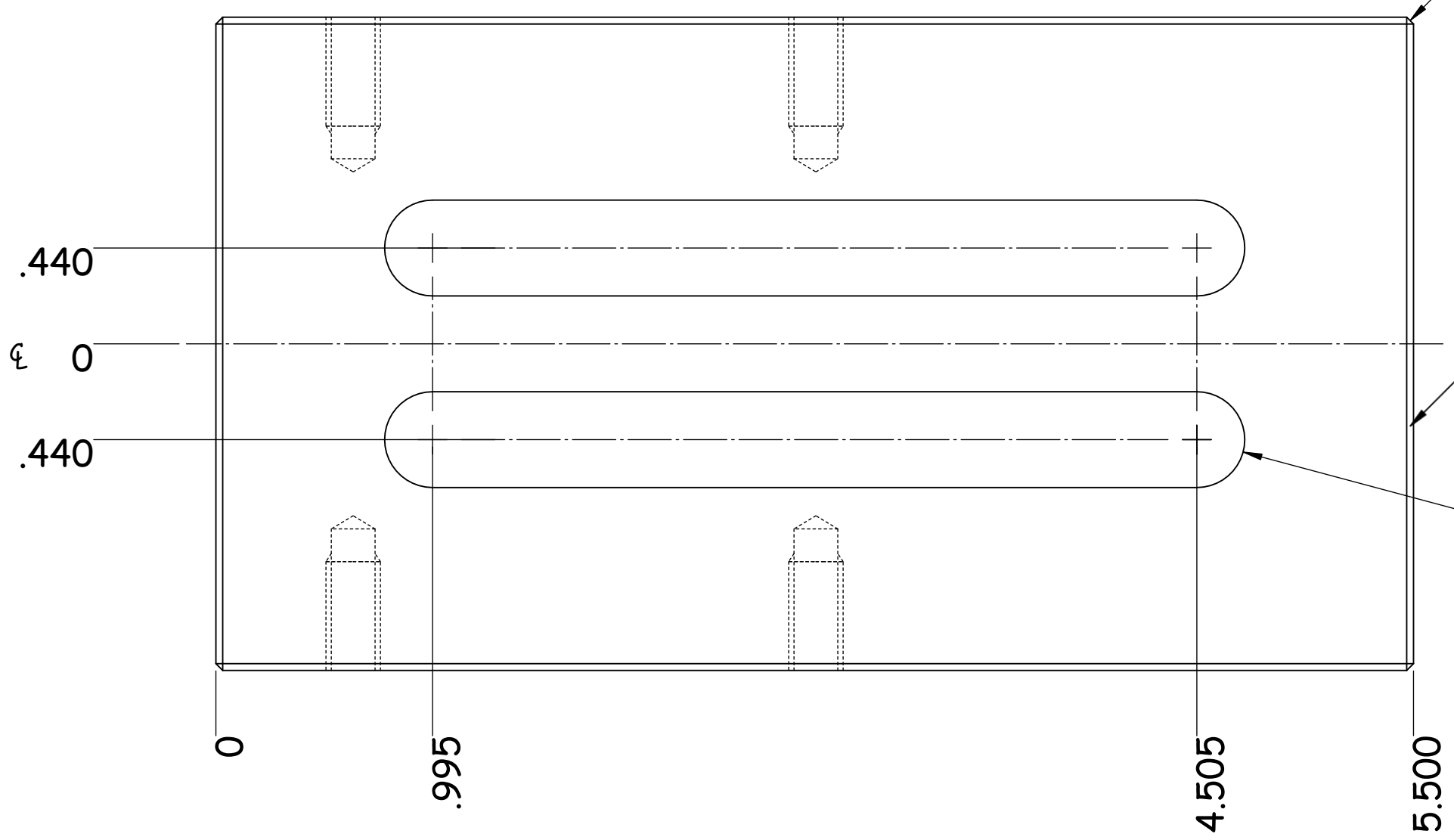
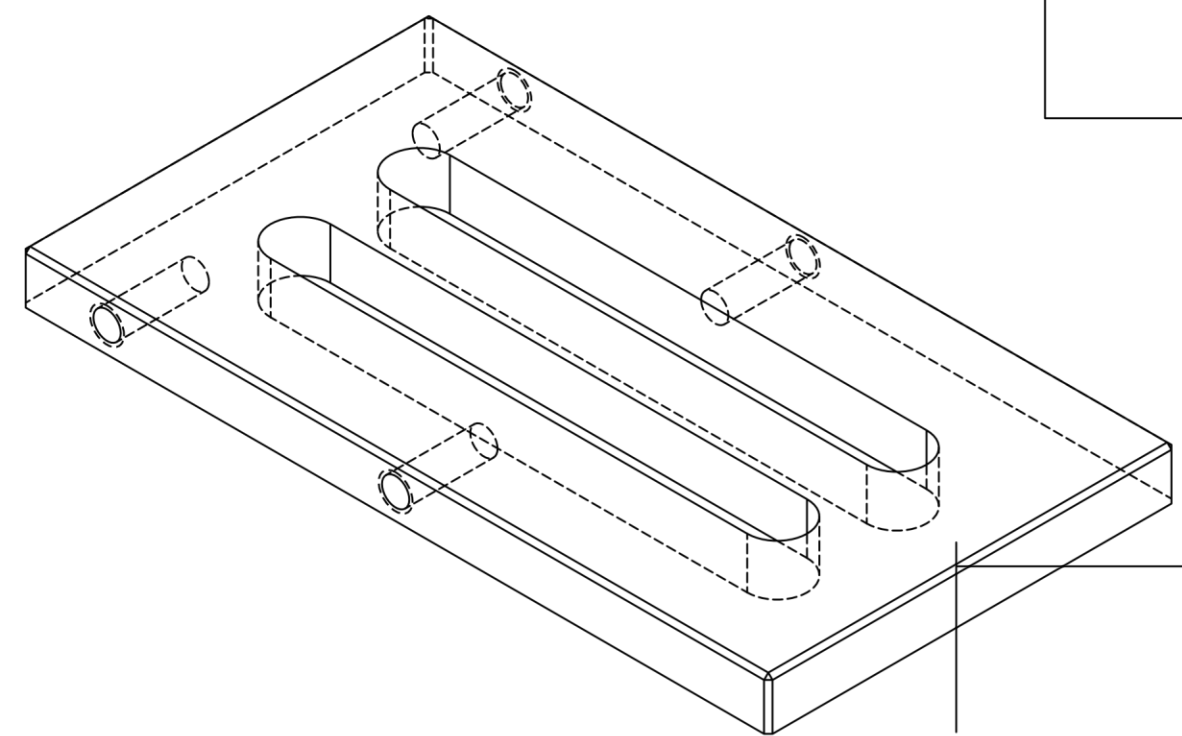

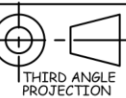
REV. No.		RELEASED	011/11/2018	JOSÉ FÉLIX
REVISIONS		DATE	BY	
			<small>THIS DRAWING AND INFORMATION CONTAINED HERE ARE EXCLUSIVE PROPERTY OF KUFFERATH AND SHALL BE RETURNED UPON DEMAND AND SHALL NOT BE REPRODUCED IN WHOLE OR IN PARTS.</small>	
KUFFERATH Testing Technology GROUP		<small>UNLESS OTHERWISE SPECIFIED DIMENSIONS ARE INCH OR [MM].</small> TOLERANCE: 0.0 = ± .1 0.00 = ± .01 0.000 = ± .001 0.0000 = ± .0005 FRACTIONAL = ± .002 ANGULAR = ± 1° ◆ CRITICAL CHARACTERISTIC		

PROJECT	WORK TYPE	H&T	FINISH			
MR-01	NEW PART	N/A	MILLING			
MATERIAL	STOCK SIZE	CYLINDER STOCK SIZE	DESIGNED BY:	DRAWN BY:	APPROVED BY:	REVIEWED BY:
ALUMINUM TOOLING PLATE	L 3"	ϕ N/A L N/A	JOSÉ FÉLIX	JOSÉ FÉLIX	JAVIER MOLINA	JAVIER MOLINA



31

756

500

QTY



1

REV. No.		BY	JOSÉ FÉLIX
		 <p>THIS DRAWING AND INFORMATION CONTAINED HERE ARE EXCLUSIVE PROPERTY OF KUFFERATH AND SHALL BE RETURNED UPON DEMAND AND SHALL NOT BE REPRODUCED IN WHOLE OR IN PARTS.</p>	
		<p>UNLESS OTHERWISE SPECIFIED DIMENSIONS ARE INCH OR [MM]. TOLERANCE: 0.0 = ± .1 0.00 = ± .01 0.000 = ± .001 0.0000 = ± .0005 FRACTIONAL = ± .002 ANGULAR = ± 1° ◆ CRITICAL CHARACTERISTIC</p>	

PROJECT		WORK TYPE		H&T		FINISH		
MR-01		NEW PART		N/A		MILLING		
MATERIAL	STOCK SIZE		CYLINDER STOCK SIZE		DESIGNED BY:	DRAWN BY:	APPROVED BY:	REVIEWED BY:
ALUMINUM TOOLING PLATE	THK		Ø	L	JOSÉ FÉLIX	JOSÉ FÉLIX	JAVIER MOLINA	JAVIER MOLINA
DESCRIPTION	3/8"		N/A	N/A				
			-PART NUMBER			TREATMENT		



QTY

PROJECT	WORK TYPE	CYLINDER STOCK SIZE		H&T	FINISH			
MR-01	NEW PART	L	Ø	N/A	MILLING			
MATERIAL	STOCK SIZE	L	Ø	DESIGNED BY:	DRAWN BY:	APPROVED BY:	REVIEWED BY:	
ALUMINUM TOOLING PLATE	3"	N/A	N/A	JOSÉ FÉLIX	JOSÉ FÉLIX	JAVIER MOLINA	JAVIER MOLINA	
6 PLACA GUIA EJE Z		5	7	- MR-01-005		4	6	5 5
				ANODIZED BLACK				2 4

RELEASED		011/11/2018	JOSÉ FÉLIX
REV. No.	REVISIONS	DATE	BY
		 <small>THIS DRAWING AND INFORMATION CONTAINED HERE ARE EXCLUSIVE PROPERTY OF KUFFERATH AND SHALL BE RETURNED UPON DEMAND AND SHALL NOT BE REPRODUCED IN WHOLE OR IN PARTS.</small>	
		<small>UNLESS OTHERWISE SPECIFIED DIMENSIONS ARE INCH OR [MM].</small> <small>TOLERANCE:</small> <small>0.0 = ± .1</small> <small>0.00 = ± .01</small> <small>0.000 = ± .001</small> <small>0.0000 = ± .0005</small> <small>FRACTIONAL = ± .002</small> <small>ANGULAR = ± 1°</small> <small>◆ CRITICAL CHARACTERISTIC</small>	
			

QTY

1

REV. No.		BY	JOSÉ FÉLIX
		 THIRD ANGLE PROJECTION	<small>THIS DRAWING AND INFORMATION CONTAINED HERE ARE EXCLUSIVE PROPERTY OF KUFFERATH AND SHALL BE RETURNED UPON DEMAND AND SHALL NOT BE REPRODUCED IN WHOLE OR IN PARTS.</small>
		<small>UNLESS OTHERWISE SPECIFIED DIMENSIONS ARE INCH OR [MM]. TOLERANCE: 0.0 = ± .1 0.00 = ± .01 0.000 = ± .001 0.0000 = ± .0005 FRACTIONAL = ± .002 ANGULAR = ± 1° ◆ CRITICAL CHARACTERISTIC</small>	

PROJECT		WORK TYPE		H&T		FINISH		
MR-01		NEW PART		N/A		MILLING		
MATERIAL	STOCK SIZE		CYLINDER STOCK SIZE		DESIGNED BY:	DRAWN BY:	APPROVED BY:	REVIEWED BY:
ALUMINUM TOOLING PLATE	THK		∅	L	JOSÉ FÉLIX	JOSÉ FÉLIX	JAVIER MOLINA	JAVIER MOLINA
	3/8"		N/A	N/A				

TITLE 1 3

2

1

8

7

6

5

4

3

2

1



F

F

A

QTY

PROJECT		WORK TYPE		H&T		FINISH		
MR-01		NEW PART		N/A		MILLING		
MATERIAL	STOCK SIZE		CYLINDER STOCK SIZE		DESIGNED BY:	DRAWN BY:	APPROVED BY:	REVIEWED BY:
ALUMINUM TOOLING PLATE		L 3"	∅ N/A	L N/A	JOSÉ FÉLIX	JOSÉ FÉLIX	JAVIER MOLINA	JAVIER MOLINA



	RELEASED	011/11/2018	JOSÉ FÉLIX
REV. No.	REVISIONS	DATE	BY
		 <small>THIS DRAWING AND INFORMATION CONTAINED HERE ARE EXCLUSIVE PROPERTY OF KUFFERATH AND SHALL BE RETURNED UPON DEMAND AND SHALL NOT BE REPRODUCED IN WHOLE OR IN PARTS.</small>	
		<small>UNLESS OTHERWISE SPECIFIED DIMENSIONS ARE INCH OR [MM].</small> <small>TOLERANCE:</small> <small>0.0 = ± .1</small> <small>0.00 = ± .01</small> <small>0.000 = ± .001</small> <small>0.0000 = ± .0005</small> <small>FRACTIONAL = ± .002</small> <small>ANGULAR = ± 1°</small> <small>◆ CRITICAL CHARACTERISTIC</small>	

KUFFERATH
Testing Technology GROUP

QTY

1



PROJECT		WORK TYPE		H&T		FINISH		
MR-01		NEW PART		N/A		MILLING		
MATERIAL	STOCK SIZE		CYLINDER STOCK SIZE		DESIGNED BY:	DRAWN BY:	APPROVED BY:	REVIEWED BY:
ALUMINUM TOOLING PLATE	THK		Ø	L	JOSÉ FÉLIX	JOSÉ FÉLIX	JAVIER MOLINA	JAVIER MOLINA
	3/8"		N/A	N/A				

REV. No.		BY	JOSÉ FÉLIX
			
		<p>THIS DRAWING AND INFORMATION CONTAINED HERE ARE EXCLUSIVE PROPERTY OF KUFFERATH AND SHALL BE RETURNED UPON DEMAND AND SHALL NOT BE REPRODUCED IN WHOLE OR IN PARTS.</p> <p>UNLESS OTHERWISE SPECIFIED DIMENSIONS ARE INCH OR [MM]. TOLERANCE: 0.0 = ± .1 0.00 = ± .01 0.000 = ± .001 0.0000 = ± .0005 FRACTIONAL = ± .002 ANGULAR = ± 1° ◆ CRITICAL CHARACTERISTIC</p>	

MR-01-005

QTY

PROJECT		WORK TYPE		H&T		FINISH		
MR-01		NEW PART		N/A		MILLING		
MATERIAL	STOCK SIZE		CYLINDER STOCK SIZE		DESIGNED BY:	DRAWN BY:	APPROVED BY:	REVIEWED BY:
ALUMINUM TOOLING PLATE		L 3"	Ø N/A	L N/A	JOSÉ FÉLIX	JOSÉ FÉLIX	JAVIER MOLINA	JAVIER MOLINA

	RELEASED	011/11/2018	JOSÉ FÉLIX
REV. No.	REVISIONS	DATE	BY
			
		<p>THIS DRAWING AND INFORMATION CONTAINED HERE ARE EXCLUSIVE PROPERTY OF KUFFERATH AND SHALL BE RETURNED UPON DEMAND AND SHALL NOT BE REPRODUCED IN WHOLE OR IN PARTS.</p> <p>UNLESS OTHERWISE SPECIFIED DIMENSIONS ARE INCH OR [MM]. TOLERANCE: 0.0 = ± .1 0.00 = ± .01 0.000 = ± .001 0.0000 = ± .0005 FRACTIONAL = ± .002 ANGULAR = ± 1° ◆ CRITICAL CHARACTERISTIC</p>	



QTY

1

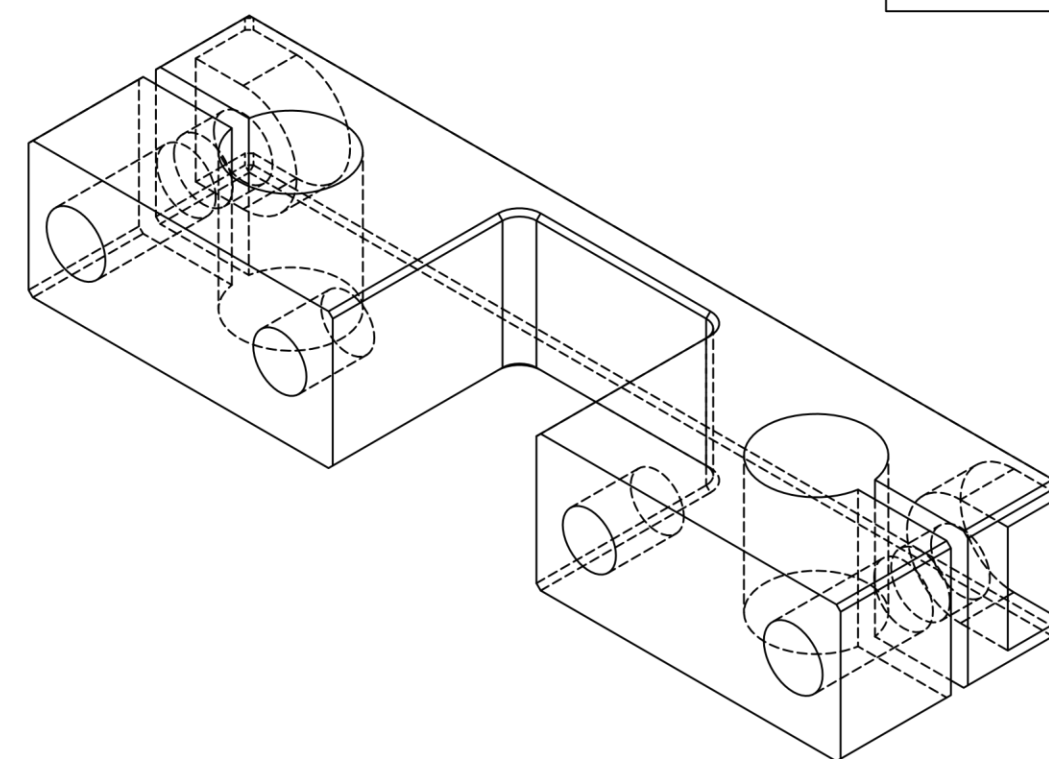
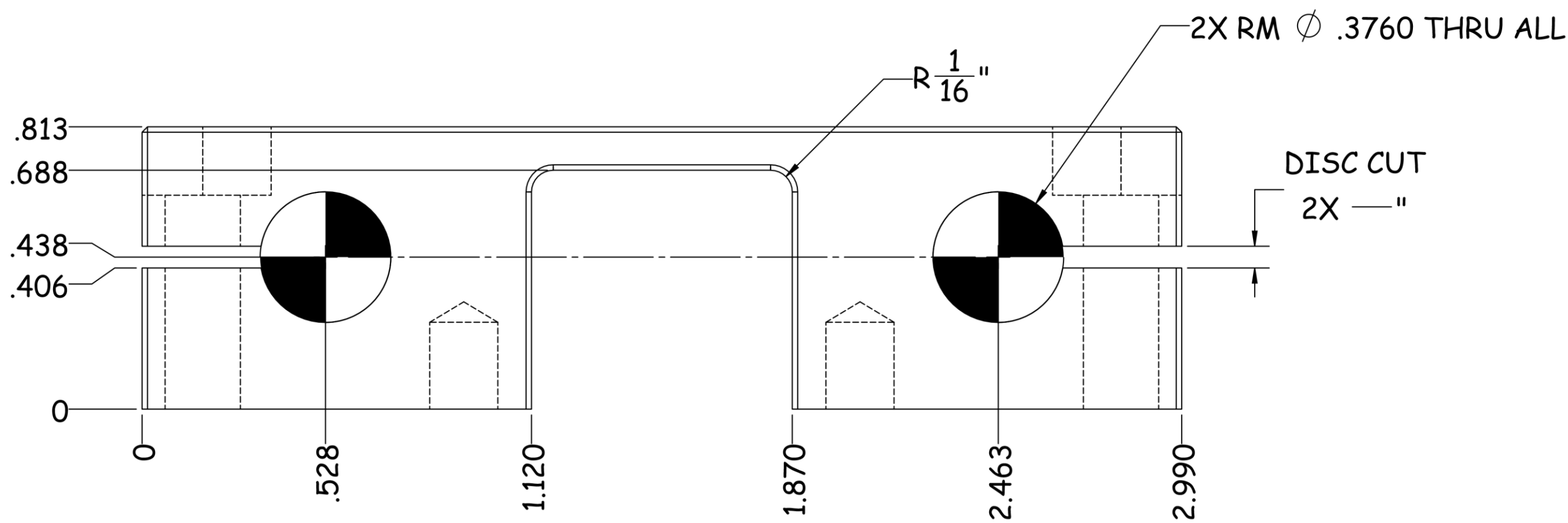
2



PROJECT	WORK TYPE	H&T	FINISH
MR-01	NEW PART	N/A	MILLING
MATERIAL	STOCK SIZE	CYLINDER STOCK SIZE	DESIGNED BY:
ALUMINUM TOOLING PLATE	THK 3/8"	Ø L N/A N/A	JOSÉ FÉLIX
			DRAWN BY:
			JOSÉ FÉLIX
			APPROVED BY:
			JAVIER MOLINA
			REVIEWED BY:
			JAVIER MOLINA

REV. No.	BY
	JOSÉ FÉLIX
	
	
<p>THIS DRAWING AND INFORMATION CONTAINED HERE ARE EXCLUSIVE PROPERTY OF KUFFERATH AND SHALL BE RETURNED UPON DEMAND AND SHALL NOT BE REPRODUCED IN WHOLE OR IN PARTS.</p> <p>THIRD ANGLE PROJECTION</p> <p>UNLESS OTHERWISE SPECIFIED DIMENSIONS ARE INCH OR [MM]. TOLERANCE: 0.0 = ±.1 0.00 = ±.01 0.000 = ±.001 0.0000 = ±.0005 FRACTIONAL = ±.002 ANGULAR = ± 1° ♦ CRITICAL CHARACTERISTIC</p>	

DESCRIPTION PART NUMBER SOPORTE DE FLECHAS MR-01-006

QTY

PROJECT		WORK TYPE		H&T		FINISH			
MR-01		NEW PART		N/A		MILLING			
MATERIAL	STOCK SIZE		CYLINDER STOCK SIZE		DESIGNED BY:	DRAWN BY:	APPROVED BY:	REVIEWED BY:	
ALUMINUM TOOLING PLATE	THK	W	L	Ø	L	JOSÉ FÉLIX	JOSÉ FÉLIX	JAVIER MOLINA	JAVIER MOLINA
		3"	N/A	N/A					

	RELEASED	011/11/2018	JOSÉ FÉLIX
REV. No.	REVISIONS	DATE	BY



KUFFERATH
Testing Technology GROUP

THIRD ANGLE PROJECTION



THIS DRAWING AND INFORMATION CONTAINED HERE ARE EXCLUSIVE PROPERTY OF KUFFERATH AND SHALL BE RETURNED UPON DEMAND AND SHALL NOT BE REPRODUCED IN WHOLE OR IN PARTS.

UNLESS OTHERWISE SPECIFIED DIMENSIONS ARE INCH OR [MM].
TOLERANCE:
0.0 = ± .1
0.00 = ± .01
0.000 = ± .001
0.0000 = ± .0005
FRACTIONAL = ± .002
ANGULAR = ± 1°
◆ CRITICAL CHARACTERISTIC

QTY

1

PROJECT		WORK TYPE		H&T		FINISH		
MR-01		NEW PART		N/A		MILLING		
MATERIAL	STOCK SIZE		CYLINDER STOCK SIZE		DESIGNED BY:	DRAWN BY:	APPROVED BY:	REVIEWED BY:
ALUMINUM TOOLING PLATE	THK		Ø	L	JOSÉ FÉLIX	JOSÉ FÉLIX	JAVIER MOLINA	JAVIER MOLINA
	3/8"	7/8"	N/A	N/A				

REV. No.		BY	JOSÉ FÉLIX
		 <p>THIS DRAWING AND INFORMATION CONTAINED HERE ARE EXCLUSIVE PROPERTY OF KUFFERATH AND SHALL BE RETURNED UPON DEMAND AND SHALL NOT BE REPRODUCED IN WHOLE OR IN PARTS.</p>	
		<p>UNLESS OTHERWISE SPECIFIED DIMENSIONS ARE INCH OR [MM]. TOLERANCE: 0.0 = ±.1 0.00 = ±.01 0.000 = ±.001 0.0000 = ±.0005 FRACTIONAL = ±.002 ANGULAR = ± 1° ◆ CRITICAL CHARACTERISTIC</p>	

QTY

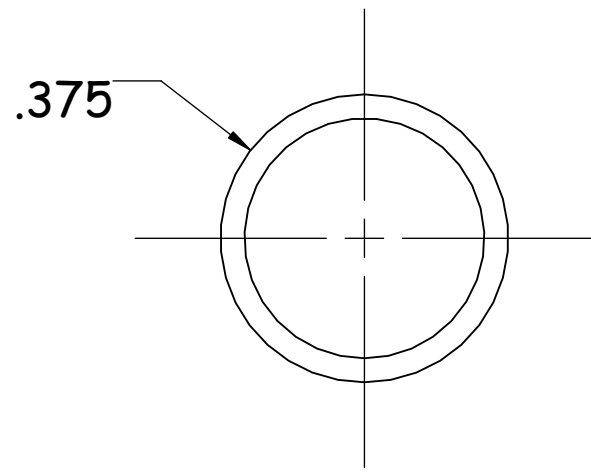

$\frac{1}{32}$

2

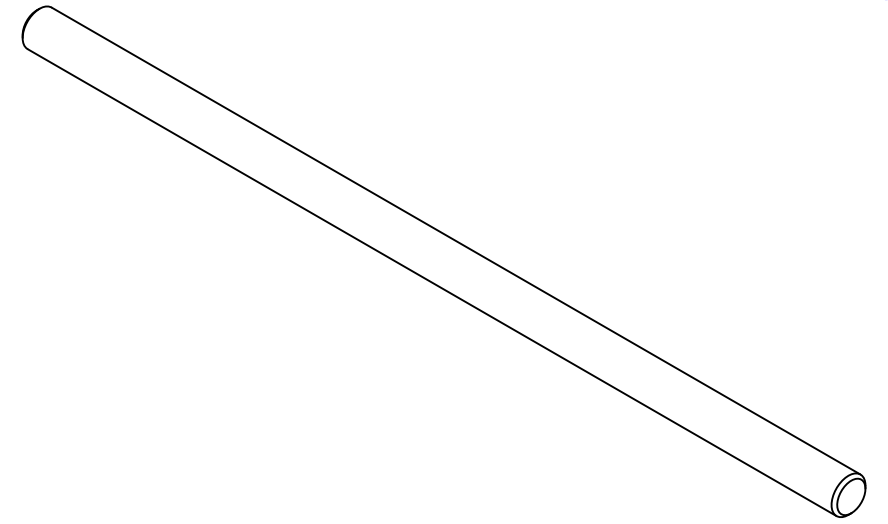

Ø

2X " X 45.0°

9.000

PROJECT	WORK TYPE	H&T	TREATMENT
MR-01	NEW PART	N/A	N/A
DESCRIPTION	STOCK SIZE	CYLINDER STOCK SIZE	DESIGNED BY:
			JOSÉ FÉLIX
		DRAWN BY:	APPROVED BY:
		JOSÉ FÉLIX	JAVIER MOLINA
		REVIEWED BY:	
		JAVIER MOLINA	



RELEASED		JOSÉ FÉLIX
REV. No.	REVISIONS	DATE BY
		<p>THIS DRAWING AND INFORMATION CONTAINED HERE ARE EXCLUSIVE PROPERTY OF KUFFERATH AND SHALL BE RETURNED UPON DEMAND AND SHALL NOT BE REPRODUCED IN WHOLE OR IN PARTS.</p> <p>UNLESS OTHERWISE SPECIFIED DIMENSIONS ARE INCH OR [MM]. TOLERANCE: 0.0 = ±.1 0.00 = ±.01 0.000 = ±.001 0.0000 = ±.0005 FRACTIONAL = ±.002 ANGULAR = ± 1° ◆ CRITICAL CHARACTERISTIC</p>

QTY

1



PROJECT	WORK TYPE	H&T	TREATMENT
MR-01	NEW PART	N/A	N/A
	STOCK SIZE	CYLINDER STOCK SIZE	DESIGNED BY:
			JOSÉ FÉLIX
			DRAWN BY:
			JOSÉ FÉLIX
			APPROVED BY:
			JAVIER MOLINA
			REVIEWED BY:
			JAVIER MOLINA

FLECHAS GUIAS

REV. No.	REVISIONS	DATE	BY
		01/11/2018	JOSÉ FÉLIX
		 <p>THIS DRAWING AND INFORMATION CONTAINED HERE ARE EXCLUSIVE PROPERTY OF KUFFERATH AND SHALL BE RETURNED UPON DEMAND AND SHALL NOT BE REPRODUCED IN WHOLE OR IN PARTS.</p>	
		<p>UNLESS OTHERWISE SPECIFIED DIMENSIONS ARE INCH OR [MM]. TOLERANCE: 0.0 = ± .1 0.00 = ± .01 0.000 = ± .001 0.0000 = ± .0005 FRACTIONAL = ± .002 ANGULAR = ± 1° ◆ CRITICAL CHARACTERISTIC</p>	

QTY

1

RELEASED		011/11/2018	JOSÉ FÉLIX
REV. No.	REVISIONS	DATE	BY
		 <small>THIS DRAWING AND INFORMATION CONTAINED HERE ARE EXCLUSIVE PROPERTY OF KUFFERATH AND SHALL BE RETURNED UPON DEMAND AND SHALL NOT BE REPRODUCED IN WHOLE OR IN PARTS.</small>	
		<small>UNLESS OTHERWISE SPECIFIED DIMENSIONS ARE INCH OR [MM].</small> <small>TOLERANCE:</small> <small>0.0 = ± .1</small> <small>0.00 = ± .01</small> <small>0.000 = ± .001</small> <small>0.0000 = ± .0005</small> <small>FRACTIONAL = ± .002</small> <small>ANGULAR = ± 1°</small> <small>◆ CRITICAL CHARACTERISTIC</small>	
			

PROJECT	WORK TYPE	CYLINDER STOCK SIZE			H&T	TREATMENT	FINISH	
MR-01	NEW PART				N/A	N/A	MILLING	
MATERIAL		STOCK SIZE		DESIGNED BY:	DRAWN BY:	APPROVED BY:	REVIEWED BY:	TITLE
		L	Ø	L	JOSÉ FÉLIX	JOSÉ FÉLIX	JAVIER MOLINA	JAVIER MOLINA
		3"	N/A	N/A				

QTY
1

PROJECT		WORK TYPE		H&T	TREATMENT			
MR-01		NEW PART		N/A	N/A			
		STOCK SIZE	CYLINDER STOCK SIZE	DESIGNED BY:	DRAWN BY:	APPROVED BY:	REVIEWED BY:	
				JOSÉ FÉLIX	JOSÉ FÉLIX	JAVIER MOLINA	JAVIER MOLINA	
		THK	W	L	-			

	RELEASED	01/11/2018	JOSÉ FÉLIX
REV. No.	REVISIONS	DATE	BY



KUFFERATH
Testing Technology GROUP

THIRD ANGLE PROJECTION



THIS DRAWING AND INFORMATION CONTAINED HERE ARE EXCLUSIVE PROPERTY OF KUFFERATH AND SHALL BE RETURNED UPON DEMAND AND SHALL NOT BE REPRODUCED IN WHOLE OR IN PARTS.

UNLESS OTHERWISE SPECIFIED DIMENSIONS ARE INCH OR [MM].
TOLERANCE:
 0.0 = ± .1
 0.00 = ± .01
 0.000 = ± .001
 0.0000 = ± .0005
 FRACTIONAL = ± .002
 ANGULAR = ± 1°
 ♦ CRITICAL CHARACTERISTIC

QTY

1



PROJECT	WORK TYPE	CYLINDER STOCK SIZE			H&T	TREATMENT	FINISH	
MR-01	NEW PART	L	Ø	L	N/A	N/A	MILLING	
	STOCK SIZE	3"	N/A	N/A	DESIGNED BY:	DRAWN BY:	APPROVED BY:	REVIEWED BY:
THOMSON SHAFT					JOSÉ FÉLIX	JOSÉ FÉLIX	JAVIER MOLINA	JAVIER MOLINA

REV. No.	REVISIONS	RELEASED	DATE	BY
			01/11/2018	JOSÉ FÉLIX
		 <small>THIS DRAWING AND INFORMATION CONTAINED HERE ARE EXCLUSIVE PROPERTY OF KUFFERATH AND SHALL BE RETURNED UPON DEMAND AND SHALL NOT BE REPRODUCED IN WHOLE OR IN PARTS.</small>		
		<small>UNLESS OTHERWISE SPECIFIED DIMENSIONS ARE INCH OR [MM].</small> <small>TOLERANCE:</small> <small>0.0 = ± .1</small> <small>0.00 = ± .01</small> <small>0.000 = ± .001</small> <small>0.0000 = ± .0005</small> <small>FRACTIONAL = ± .002</small> <small>ANGULAR = ± 1°</small> <small>◆ CRITICAL CHARACTERISTIC</small>		
				

QTY

1



PROJECT	WORK TYPE	H&T	TREATMENT
MR-01	NEW PART	N/A	N/A
	STOCK SIZE	CYLINDER STOCK SIZE	DESIGNED BY:
	N/A	N/A	JOSÉ FÉLIX
	N/A	N/A	DRAWN BY:
			JOSÉ FÉLIX
			APPROVED BY:
			JAVIER MOLINA
			REVIEWED BY:
			JAVIER MOLINA

REV. No.	REVISIONS	DATE	BY
		01/11/2018	JOSÉ FÉLIX
		 <p>THIS DRAWING AND INFORMATION CONTAINED HERE ARE EXCLUSIVE PROPERTY OF KUFFERATH AND SHALL BE RETURNED UPON DEMAND AND SHALL NOT BE REPRODUCED IN WHOLE OR IN PARTS.</p>	
		<p>UNLESS OTHERWISE SPECIFIED DIMENSIONS ARE INCH OR [MM]. TOLERANCE: 0.0 = ± .1 0.00 = ± .01 0.000 = ± .001 0.0000 = ± .0005 FRACTIONAL = ± .002 ANGULAR = ± 1° ◆ CRITICAL CHARACTERISTIC</p>	

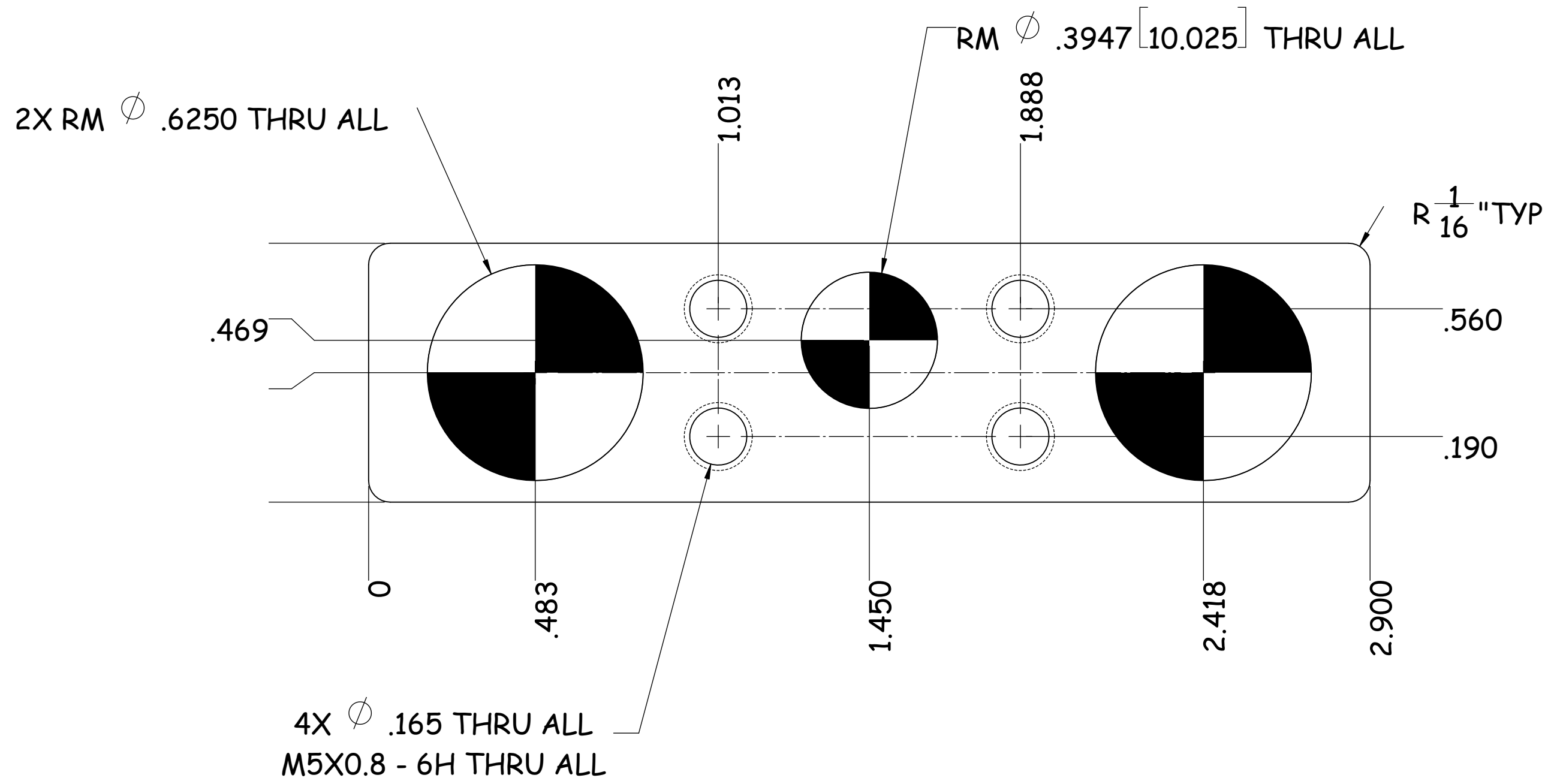
QTY
1







PROJECT	WORK TYPE	H&T	TREATMENT	FINISH	
MR-01	NEW PART	N/A	N/A	MILLING	
STOCK SIZE	CYLINDER STOCK SIZE	DESIGNED BY:	DRAWN BY:	APPROVED BY:	REVIEWED BY:
	L Ø L	JOSÉ FÉLIX	JOSÉ FÉLIX	JAVIER MOLINA	JAVIER MOLINA
.750	3" N/A N/A				

REV. No.	RELEASED	01/11/2018	JOSÉ FÉLIX
	REVISIONS	DATE	BY
			
		<p>THIS DRAWING AND INFORMATION CONTAINED HERE ARE EXCLUSIVE PROPERTY OF KUFFERATH AND SHALL BE RETURNED UPON DEMAND AND SHALL NOT BE REPRODUCED IN WHOLE OR IN PARTS.</p> <p>UNLESS OTHERWISE SPECIFIED DIMENSIONS ARE INCH OR [MM]. TOLERANCE: 0.0 = ±.1 0.00 = ±.01 0.000 = ±.001 0.0000 = ±.0005 FRACTIONAL = ±.002 ANGULAR = ± 1° ◆ CRITICAL CHARACTERISTIC</p>	

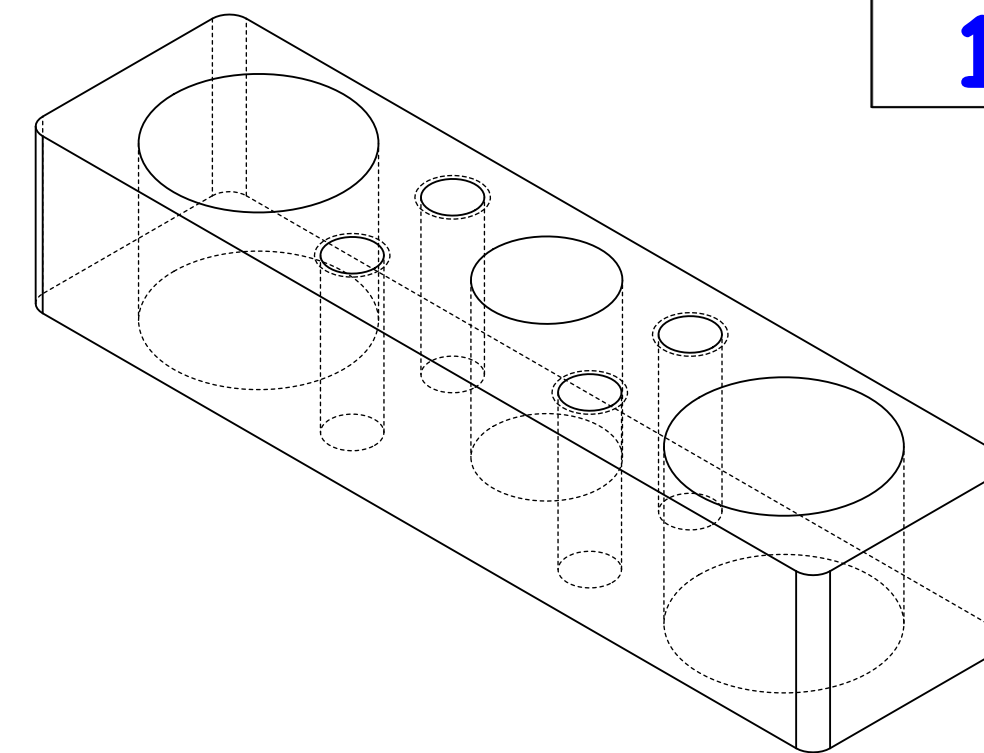
QTY

1



0	RELEASED	01/11/2018	JOSÉ FÉLIX
REV. No.	REVISIONS	DATE	BY
			
		<p>THIS DRAWING AND INFORMATION CONTAINED HERE ARE EXCLUSIVE PROPERTY OF KUFFERATH AND SHALL BE RETURNED UPON DEMAND AND SHALL NOT BE REPRODUCED IN WHOLE OR IN PARTS.</p> <p>UNLESS OTHERWISE SPECIFIED DIMENSIONS ARE INCH OR [MM]. TOLERANCE: 0.0 = ± .1 0.00 = ± .01 0.000 = ± .001 0.0000 = ± .0005 FRACTIONAL = ± .002 ANGULAR = ± 1° ◆ CRITICAL CHARACTERISTIC</p>	



PROJECT	WORK TYPE	H&T	TREATMENT
MR-01	NEW PART	N/A	N/A
	STOCK SIZE	CYLINDER STOCK SIZE	DESIGNED BY:
			JOSÉ FÉLIX
			DRAWN BY:
			JOSÉ FÉLIX
			APPROVED BY:
			JAVIER MOLINA
			REVIEWED BY:
			JAVIER MOLINA

.375

QTY

1



PROJECT	WORK TYPE	CYLINDER STOCK SIZE			H&T	TREATMENT	FINISH	
MR-01	NEW PART	L	Ø	L	N/A	N/A	MILLING	
	STOCK SIZE	3"	N/A	N/A	DESIGNED BY:	DRAWN BY:	APPROVED BY:	REVIEWED BY:
					JOSÉ FÉLIX	JOSÉ FÉLIX	JAVIER MOLINA	JAVIER MOLINA

REV. No.	REVISIONS	RELEASED	DATE	BY
			01/11/2018	JOSÉ FÉLIX
		 <p>THIS DRAWING AND INFORMATION CONTAINED HERE ARE EXCLUSIVE PROPERTY OF KUFFERATH AND SHALL BE RETURNED UPON DEMAND AND SHALL NOT BE REPRODUCED IN WHOLE OR IN PARTS.</p>		
		<p>UNLESS OTHERWISE SPECIFIED DIMENSIONS ARE INCH OR [MM].</p> <p>TOLERANCE:</p> <p>0.0 = ± .1</p> <p>0.00 = ± .01</p> <p>0.000 = ± .001</p> <p>0.0000 = ± .0005</p> <p>FRACTIONAL = ± .002</p> <p>ANGULAR = ± 1°</p> <p>◆ CRITICAL CHARACTERISTIC</p>		
				

QTY

1



PROJECT	WORK TYPE	H&T	TREATMENT
MR-01	NEW PART	N/A	N/A
	STOCK SIZE	CYLINDER STOCK SIZE	DESIGNED BY:
			JOSÉ FÉLIX
			DRAWN BY:
			JOSÉ FÉLIX
			APPROVED BY:
			JAVIER MOLINA
			REVIEWED BY:
			JAVIER MOLINA

REV. No.	REVISIONS	RELEASED	DATE	BY
			01/11/2018	JOSÉ FÉLIX
				
		<small>THIS DRAWING AND INFORMATION CONTAINED HERE ARE EXCLUSIVE PROPERTY OF KUFFERATH AND SHALL BE RETURNED UPON DEMAND AND SHALL NOT BE REPRODUCED IN WHOLE OR IN PARTS.</small>		
		<small>UNLESS OTHERWISE SPECIFIED DIMENSIONS ARE INCH OR [MM].</small> <small>TOLERANCE:</small> <small>0.0 = ± .1</small> <small>0.00 = ± .01</small> <small>0.000 = ± .001</small> <small>0.0000 = ± .0005</small> <small>FRACTIONAL = ± .002</small> <small>ANGULAR = ± 1°</small> <small>◆ CRITICAL CHARACTERISTIC</small>		

QTY

1



PROJECT	WORK TYPE	CYLINDER STOCK SIZE			H&T	TREATMENT	FINISH	
MR-01	NEW PART				N/A	N/A	MILLING	
DESCRIPTION	PART NUMBER	STOCK SIZE		DESIGNED BY:	DRAWN BY:	APPROVED BY:	REVIEWED BY:	
		L	Ø					
	MR-4	3"	N/A	JOSÉ FÉLIX	JOSÉ FÉLIX	JAVIER MOLINA	JAVIER MOLINA	

RELEASED		011/11/2018	JOSÉ FÉLIX
REV. No.	REVISIONS	DATE	BY
			
<small>THIS DRAWING AND INFORMATION CONTAINED HERE ARE EXCLUSIVE PROPERTY OF KUFFERATH AND SHALL BE RETURNED UPON DEMAND AND SHALL NOT BE REPRODUCED IN WHOLE OR IN PARTS.</small>			
<small>UNLESS OTHERWISE SPECIFIED DIMENSIONS ARE INCH OR [MM].</small>			
<small>TOLERANCE:</small> 0.0 = ± .1 0.00 = ± .01 0.000 = ± .001 0.0000 = ± .0005 FRACTIONAL = ± .002 ANGULAR = ± 1° ◆ CRITICAL CHARACTERISTIC			
			

QTY



1

PROJECT	WORK TYPE	H&T	TREATMENT
MR-01	NEW PART	N/A	N/A
	STOCK SIZE	CYLINDER STOCK SIZE	DESIGNED BY:
			JOSÉ FÉLIX
			DRAWN BY:
			JOSÉ FÉLIX
			APPROVED BY:
			JAVIER MOLINA
			REVIEWED BY:
			JAVIER MOLINA

REV. No.	REVISIONS	DATE	BY
		01/11/2018	JOSÉ FÉLIX
		 <p>THIS DRAWING AND INFORMATION CONTAINED HERE ARE EXCLUSIVE PROPERTY OF KUFFERATH AND SHALL BE RETURNED UPON DEMAND AND SHALL NOT BE REPRODUCED IN WHOLE OR IN PARTS.</p>	
		<p>UNLESS OTHERWISE SPECIFIED DIMENSIONS ARE INCH OR [MM]. TOLERANCE: 0.0 = ± .1 0.00 = ± .01 0.000 = ± .001 0.0000 = ± .0005 FRACTIONAL = ± .002 ANGULAR = ± 1° ◆ CRITICAL CHARACTERISTIC</p>	

QTY

1



RELEASED		011/11/2018	JOSÉ FÉLIX
REV. No.	REVISIONS	DATE	BY
		 THIRD ANGLE PROJECTION	<small>THIS DRAWING AND INFORMATION CONTAINED HERE ARE EXCLUSIVE PROPERTY OF KUFFERATH AND SHALL BE RETURNED UPON DEMAND AND SHALL NOT BE REPRODUCED IN WHOLE OR IN PARTS.</small>
			

PROJECT	WORK TYPE	CYLINDER STOCK SIZE			H&T	TREATMENT	FINISH	
MR-01	NEW PART				N/A	N/A	MILLING	
MATERIAL	STOCK SIZE		L	Ø	DESIGNED BY:	DRAWN BY:	APPROVED BY:	REVIEWED BY:
			3"	N/A				
TITLE								

QTY



1

PROJECT	WORK TYPE	H&T	TREATMENT
MR-01	NEW PART	N/A	N/A
	STOCK SIZE	CYLINDER STOCK SIZE	DESIGNED BY:
			JOSÉ FÉLIX
			DRAWN BY:
			JOSÉ FÉLIX
			APPROVED BY:
			JAVIER MOLINA
			REVIEWED BY:
			JAVIER MOLINA

REV. No.	REVISIONS	DATE	BY
		01/11/2018	JOSÉ FÉLIX
		 <p>THIS DRAWING AND INFORMATION CONTAINED HERE ARE EXCLUSIVE PROPERTY OF KUFFERATH AND SHALL BE RETURNED UPON DEMAND AND SHALL NOT BE REPRODUCED IN WHOLE OR IN PARTS.</p>	
		<p>UNLESS OTHERWISE SPECIFIED DIMENSIONS ARE INCH OR [MM]. TOLERANCE: 0.0 = ± .1 0.00 = ± .01 0.000 = ± .001 0.0000 = ± .0005 FRACTIONAL = ± .002 ANGULAR = ± 1° ◆ CRITICAL CHARACTERISTIC</p>	

QTY

1

RELEASED		011/11/2018	JOSÉ FÉLIX
REV. No.	REVISIONS	DATE	BY
		 THIRD ANGLE PROJECTION	<small>THIS DRAWING AND INFORMATION CONTAINED HERE ARE EXCLUSIVE PROPERTY OF KUFFERATH AND SHALL BE RETURNED UPON DEMAND AND SHALL NOT BE REPRODUCED IN WHOLE OR IN PARTS.</small>
			

PROJECT	WORK TYPE	CYLINDER STOCK SIZE			H&T	TREATMENT	FINISH	
MR-01	NEW PART	L	Ø	L	N/A	N/A	MILLING	
	STOCK SIZE	3"	N/A	N/A	DESIGNED BY:	DRAWN BY:	APPROVED BY:	REVIEWED BY:
1018 CRS					JOSÉ FÉLIX	JOSÉ FÉLIX	JAVIER MOLINA	JAVIER MOLINA

MR-01-008

8

7

6

5

4

3

2

1

F

F

A

QTY

1

PROJECT		WORK TYPE		H&T	TREATMENT		
MR-01		NEW PART		N/A	N/A		
		STOCK SIZE	CYLINDER STOCK SIZE	DESIGNED BY:	DRAWN BY:	APPROVED BY:	REVIEWED BY:
		3/4"	5/8"	JOSÉ FÉLIX	JOSÉ FÉLIX	JAVIER MOLINA	JAVIER MOLINA

	RELEASED	011/11/2018	JOSÉ FÉLIX
REV. No.	REVISIONS	DATE	BY

THIS DRAWING AND INFORMATION CONTAINED HERE ARE EXCLUSIVE PROPERTY OF KUFFERATH AND SHALL BE RETURNED UPON DEMAND AND SHALL NOT BE REPRODUCED IN WHOLE OR IN PARTS.



UNLESS OTHERWISE SPECIFIED DIMENSIONS ARE INCH OR [MM].
 TOLERANCE:
 0.0 = ± .1
 0.00 = ± .01
 0.000 = ± .001
 0.0000 = ± .0005
 FRACTIONAL = ± .002
 ANGULAR = ± 1°
 ◆ CRITICAL CHARACTERISTIC

QTY

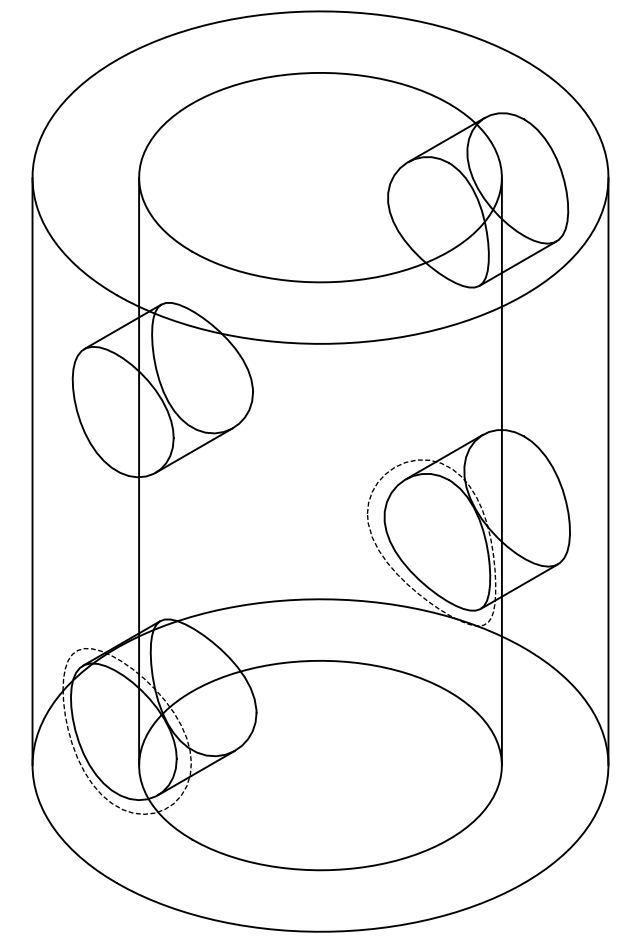
1



Ø .130 THRU ALL
M4X0.7 - 6H THRU ALL

0	RELEASED	01/11/2018	JOSÉ FÉLIX
REV. No.	REVISIONS	DATE	BY
			
		<p>THIS DRAWING AND INFORMATION CONTAINED HERE ARE EXCLUSIVE PROPERTY OF KUFFERATH AND SHALL BE RETURNED UPON DEMAND AND SHALL NOT BE REPRODUCED IN WHOLE OR IN PARTS.</p> <p>UNLESS OTHERWISE SPECIFIED DIMENSIONS ARE INCH OR [MM]. TOLERANCE: 0.0 = ± .1 0.00 = ± .01 0.000 = ± .001 0.0000 = ± .0005 FRACTIONAL = ± .002 ANGULAR = ± 1° ◆ CRITICAL CHARACTERISTIC</p>	

PROJECT	WORK TYPE	CYLINDER STOCK SIZE			H&T	TREATMENT	FINISH	
MR-01	NEW PART	L	Ø	L	N/A	N/A	MILLING	
	STOCK SIZE	3"	N/A	N/A	DESIGNED BY:	DRAWN BY:	APPROVED BY:	REVIEWED BY:
					JOSÉ FÉLIX	JOSÉ FÉLIX	JAVIER MOLINA	JAVIER MOLINA

QTY

1

PROJECT	WORK TYPE	H&T	TREATMENT			
MR-01	NEW PART	N/A	N/A			
STOCK SIZE		CYLINDER STOCK SIZE	DESIGNED BY:	DRAWN BY:	APPROVED BY:	REVIEWED BY:
			JOSÉ FÉLIX	JOSÉ FÉLIX	JAVIER MOLINA	JAVIER MOLINA

REV. No.	REVISIONS	DATE	BY
	RELEASED	01/11/2018	JOSÉ FÉLIX

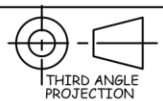

THIS DRAWING AND INFORMATION CONTAINED HERE ARE EXCLUSIVE PROPERTY OF KUFFERATH AND SHALL BE RETURNED UPON DEMAND AND SHALL NOT BE REPRODUCED IN WHOLE OR IN PARTS.

KUFFERATH
Testing Technology GROUP

UNLESS OTHERWISE SPECIFIED DIMENSIONS ARE INCH OR [MM].
 TOLERANCE:
 0.0 = ± .1
 0.00 = ± .01
 0.000 = ± .001
 0.0000 = ± .0005
 FRACTIONAL = ± .002
 ANGULAR = ± 1°
 ♦ CRITICAL CHARACTERISTIC



6 5 7 0 4 6 3 5 25 4 65 3 25 2 1

QTY

1

DESCRIPTION	W	L	PART NUMBER	FINISH	TITLE
-------------	---	---	-------------	--------	-------

PROJECT	WORK TYPE	H&T	TREATMENT	FINISH				
MR-01	NEW PART	N/A	N/A	MILLING				
STOCK SIZE		CYLINDER STOCK SIZE		DESIGNED BY:	DRAWN BY:	APPROVED BY:	REVIEWED BY:	
		L	∅	L	JOSÉ FÉLIX	JOSÉ FÉLIX	JAVIER MOLINA	JAVIER MOLINA
		3"	N/A	N/A				

RELEASED		011/11/2018	JOSÉ FÉLIX
REV. No.	REVISIONS	DATE	BY
			
<small>THIS DRAWING AND INFORMATION CONTAINED HERE ARE EXCLUSIVE PROPERTY OF KUFFERATH AND SHALL BE RETURNED UPON DEMAND AND SHALL NOT BE REPRODUCED IN WHOLE OR IN PARTS.</small>			
<small>UNLESS OTHERWISE SPECIFIED DIMENSIONS ARE INCH OR [MM]. TOLERANCE: 0.0 = ± .1 0.00 = ± .01 0.000 = ± .001 0.0000 = ± .0005 FRACTIONAL = ± .002 ANGULAR = ± 1° ◆ CRITICAL CHARACTERISTIC</small>			
			

QTY

1



UNION STEPPER/ LEAD SCREW N/A N/A MR-01-009

LATHE

MR-01-

PROJECT	WORK TYPE	H&T	TREATMENT
MR-01	NEW PART	N/A	N/A
STOCK SIZE	CYLINDER STOCK SIZE	DESIGNED BY:	DRAWN BY:
		JOSÉ FÉLIX	JOSÉ FÉLIX
		APPROVED BY:	REVIEWED BY:
		JAVIER MOLINA	JAVIER MOLINA

REV. No.	REVISIONS	DATE	BY
		01/11/2018	JOSÉ FÉLIX



 THIS DRAWING AND INFORMATION CONTAINED HERE ARE EXCLUSIVE PROPERTY OF KUFFERATH AND SHALL BE RETURNED UPON DEMAND AND SHALL NOT BE REPRODUCED IN WHOLE OR IN PARTS.

UNLESS OTHERWISE SPECIFIED DIMENSIONS ARE INCH OR [MM].
 TOLERANCE:
 0.0 = ± .1
 0.00 = ± .01
 0.000 = ± .001
 0.0000 = ± .0005
 FRACTIONAL = ± .002
 ANGULAR = ± 1°
 ◆ CRITICAL CHARACTERISTIC



QTY

1



MATERIAL

Ø

L

009

PROJECT	WORK TYPE	CYLINDER STOCK SIZE			H&T	TREATMENT	FINISH	
MR-01	NEW PART				N/A	N/A	MILLING	
					DESIGNED BY:	DRAWN BY:	APPROVED BY:	REVIEWED BY:
		L	Ø	L	JOSÉ FÉLIX	JOSÉ FÉLIX	JAVIER MOLINA	JAVIER MOLINA
		3"	N/A	N/A				

RELEASED		011/11/2018	JOSÉ FÉLIX
REV. No.	REVISIONS	DATE	BY
		 <p>THIS DRAWING AND INFORMATION CONTAINED HERE ARE EXCLUSIVE PROPERTY OF KUFFERATH AND SHALL BE RETURNED UPON DEMAND AND SHALL NOT BE REPRODUCED IN WHOLE OR IN PARTS.</p>	
		<p>UNLESS OTHERWISE SPECIFIED DIMENSIONS ARE INCH OR [MM]. TOLERANCE: 0.0 = ± .1 0.00 = ± .01 0.000 = ± .001 0.0000 = ± .0005 FRACTIONAL = ± .002 ANGULAR = ± 1° ◆ CRITICAL CHARACTERISTIC</p>	

QTY
1

THK 1/2" 5/8"

PROJECT		WORK TYPE		H&T	TREATMENT		
MR-01		NEW PART		N/A	N/A		
		STOCK SIZE	CYLINDER STOCK SIZE	DESIGNED BY:	DRAWN BY:	APPROVED BY:	REVIEWED BY:
				JOSÉ FÉLIX	JOSÉ FÉLIX	JAVIER MOLINA	JAVIER MOLINA

	RELEASED	011/11/2018	JOSÉ FÉLIX
REV. No.	REVISIONS	DATE	BY



KUFFERATH
Testing Technology GROUP

THIRD ANGLE PROJECTION

THIS DRAWING AND INFORMATION CONTAINED HERE ARE EXCLUSIVE PROPERTY OF KUFFERATH AND SHALL BE RETURNED UPON DEMAND AND SHALL NOT BE REPRODUCED IN WHOLE OR IN PARTS.



UNLESS OTHERWISE SPECIFIED DIMENSIONS ARE INCH OR [MM].
TOLERANCE:
 0.0 = ± .1
 0.00 = ± .01
 0.000 = ± .001
 0.0000 = ± .0005
 FRACTIONAL = ± .002
 ANGULAR = ± 1°
 ◆ CRITICAL CHARACTERISTIC

QTY

1

1018 CRS

PROJECT	WORK TYPE	H&T	TREATMENT	FINISH			
MR-01	NEW PART	N/A	N/A	MILLING			
STOCK SIZE		CYLINDER STOCK SIZE		DESIGNED BY:	DRAWN BY:	APPROVED BY:	REVIEWED BY:
	L	Ø	L	JOSÉ FÉLIX	JOSÉ FÉLIX	JAVIER MOLINA	JAVIER MOLINA
	3"	N/A	N/A				

RELEASED		011/11/2018	JOSÉ FÉLIX
REV. No.	REVISIONS	DATE	BY
		 <small>THIS DRAWING AND INFORMATION CONTAINED HERE ARE EXCLUSIVE PROPERTY OF KUFFERATH AND SHALL BE RETURNED UPON DEMAND AND SHALL NOT BE REPRODUCED IN WHOLE OR IN PARTS.</small>	
		<small>UNLESS OTHERWISE SPECIFIED DIMENSIONS ARE INCH OR [MM].</small> <small>TOLERANCE:</small> <small>0.0 = ± .1</small> <small>0.00 = ± .01</small> <small>0.000 = ± .001</small> <small>0.0000 = ± .0005</small> <small>FRACTIONAL = ± .002</small> <small>ANGULAR = ± 1°</small> <small>◆ CRITICAL CHARACTERISTIC</small>	
			



QTY

1

N/A

PROJECT	WORK TYPE	H&T	TREATMENT
MR-01	NEW PART	N/A	N/A
STOCK SIZE	CYLINDER STOCK SIZE	DESIGNED BY:	DRAWN BY:
		JOSÉ FÉLIX	JOSÉ FÉLIX
		APPROVED BY:	REVIEWED BY:
		JAVIER MOLINA	JAVIER MOLINA



REV. No.	REVISIONS	DATE	BY
		01/11/2018	JOSÉ FÉLIX



 THIS DRAWING AND INFORMATION CONTAINED HERE ARE EXCLUSIVE PROPERTY OF KUFFERATH AND SHALL BE RETURNED UPON DEMAND AND SHALL NOT BE REPRODUCED IN WHOLE OR IN PARTS.

UNLESS OTHERWISE SPECIFIED DIMENSIONS ARE INCH OR [MM].
 TOLERANCE:
 0.0 = ± .1
 0.00 = ± .01
 0.000 = ± .001
 0.0000 = ± .0005
 FRACTIONAL = ± .002
 ANGULAR = ± 1°
 ◆ CRITICAL CHARACTERISTIC



QTY
1

PROJECT	WORK TYPE	H&T	TREATMENT	FINISH			
MR-01	NEW PART	N/A	N/A	MILLING			
STOCK SIZE		CYLINDER STOCK SIZE		DESIGNED BY:	DRAWN BY:	APPROVED BY:	REVIEWED BY:
		L	Ø	L	JOSÉ FÉLIX	JOSÉ FÉLIX	JAVIER MOLINA
		3"	N/A	N/A	JOSÉ FÉLIX	JOSÉ FÉLIX	JAVIER MOLINA

RELEASED		011/11/2018	JOSÉ FÉLIX
REV. No.	REVISIONS	DATE	BY
		 <p>THIS DRAWING AND INFORMATION CONTAINED HERE ARE EXCLUSIVE PROPERTY OF KUFFERATH AND SHALL BE RETURNED UPON DEMAND AND SHALL NOT BE REPRODUCED IN WHOLE OR IN PARTS.</p>	
		<p>UNLESS OTHERWISE SPECIFIED DIMENSIONS ARE INCH OR [MM]. TOLERANCE: 0.0 = ± .1 0.00 = ± .01 0.000 = ± .001 0.0000 = ± .0005 FRACTIONAL = ± .002 ANGULAR = ± 1° ◆ CRITICAL CHARACTERISTIC</p>	

QTY

1

RELEASED		011/11/2018	JOSÉ FÉLIX
REV. No.	REVISIONS	DATE	BY
		 <small>THIS DRAWING AND INFORMATION CONTAINED HERE ARE EXCLUSIVE PROPERTY OF KUFFERATH AND SHALL BE RETURNED UPON DEMAND AND SHALL NOT BE REPRODUCED IN WHOLE OR IN PARTS.</small>	
		<small>UNLESS OTHERWISE SPECIFIED DIMENSIONS ARE INCH OR [MM].</small> <small>TOLERANCE:</small> <small>0.0 = ± .1</small> <small>0.00 = ± .01</small> <small>0.000 = ± .001</small> <small>0.0000 = ± .0005</small> <small>FRACTIONAL = ± .002</small> <small>ANGULAR = ± 1°</small> <small>◆ CRITICAL CHARACTERISTIC</small>	
			

		NEW PART		CYLINDER STOCK SIZE		DESIGNED BY:	DRAWN BY:	APPROVED BY:	REVIEWED BY:	FINISH
				N/A N/A		JOSÉ FÉLIX	JOSÉ FÉLIX	JAVIER MOLINA	JAVIER MOLINA	MILLING

QTY

F

F

→

←

PROJECT		WORK TYPE		H&T			
MR-01		NEW PART		N/A			
		STOCK SIZE		DESIGNED BY:	DRAWN BY:	APPROVED BY:	REVIEWED BY:
				JOSÉ FÉLIX	JOSÉ FÉLIX	JAVIER MOLINA	JAVIER MOLINA

	RELEASED	011/11/2018	JOSÉ FÉLIX
REV. No.	REVISIONS	DATE	BY



THIS DRAWING AND INFORMATION CONTAINED HERE ARE EXCLUSIVE PROPERTY OF KUFFERATH AND SHALL BE RETURNED UPON DEMAND AND SHALL NOT BE REPRODUCED IN WHOLE OR IN PARTS.

UNLESS OTHERWISE SPECIFIED DIMENSIONS ARE INCH OR [MM].
 TOLERANCE:
 0.0 = ± .1
 0.00 = ± .01
 0.000 = ± .001
 0.0000 = ± .0005
 FRACTIONAL = ± .002
 ANGULAR = ± 1°
 ◆ CRITICAL CHARACTERISTIC

TITLE 6 5 7 - 4 6 3 5 2 4 1 3

A

1

QTY
1

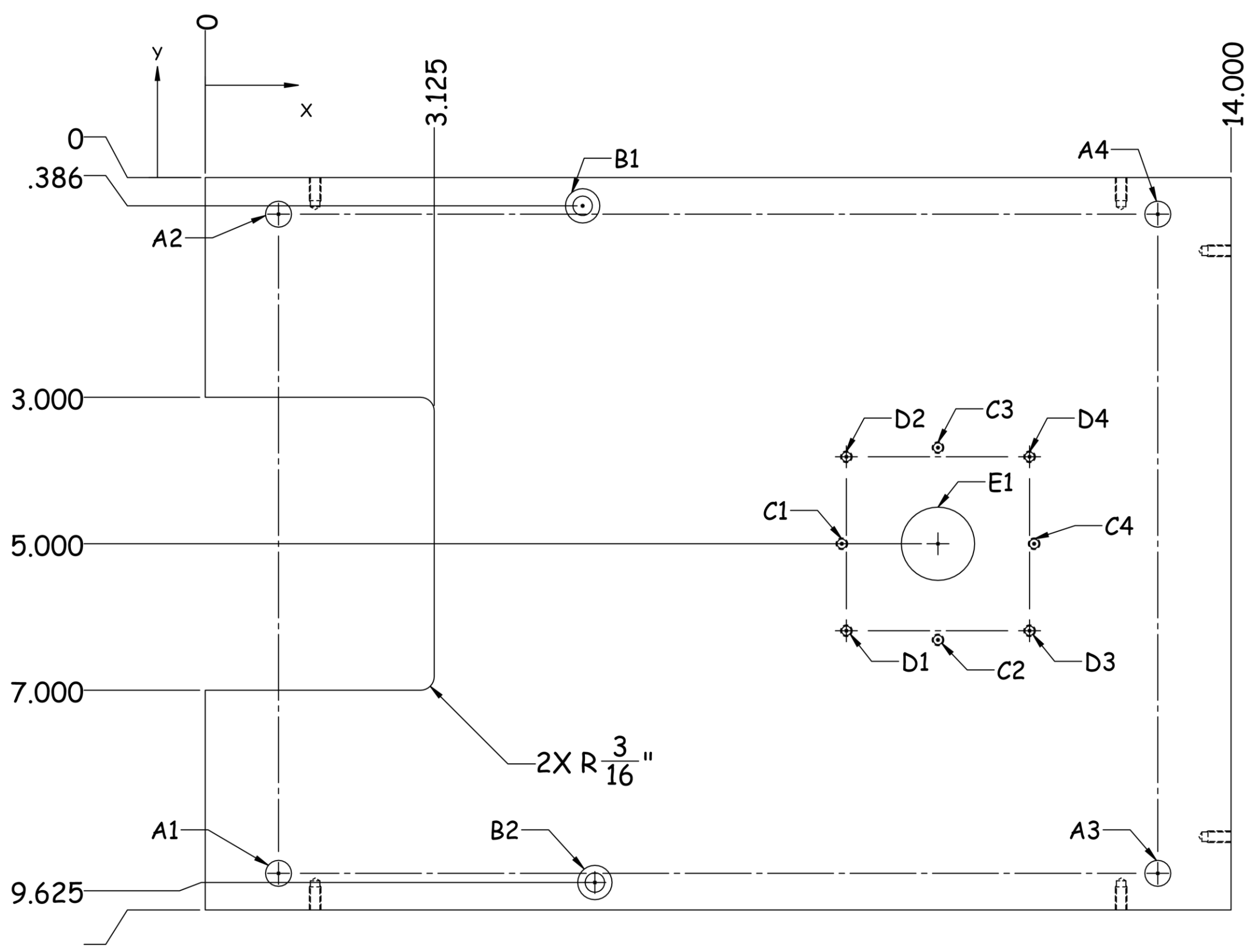
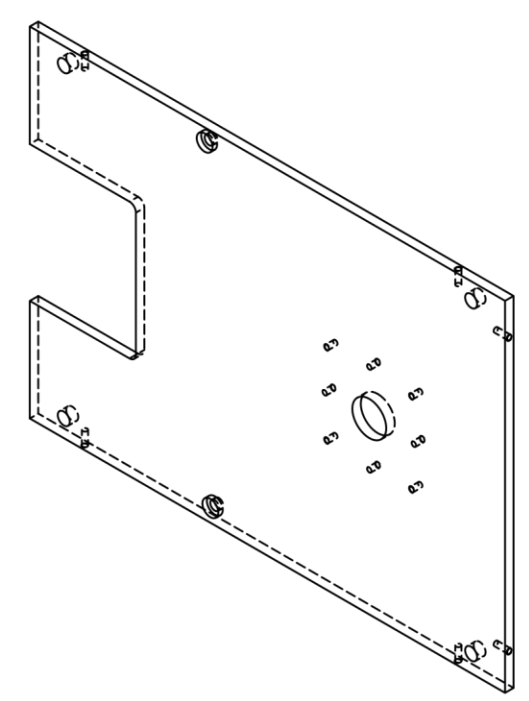
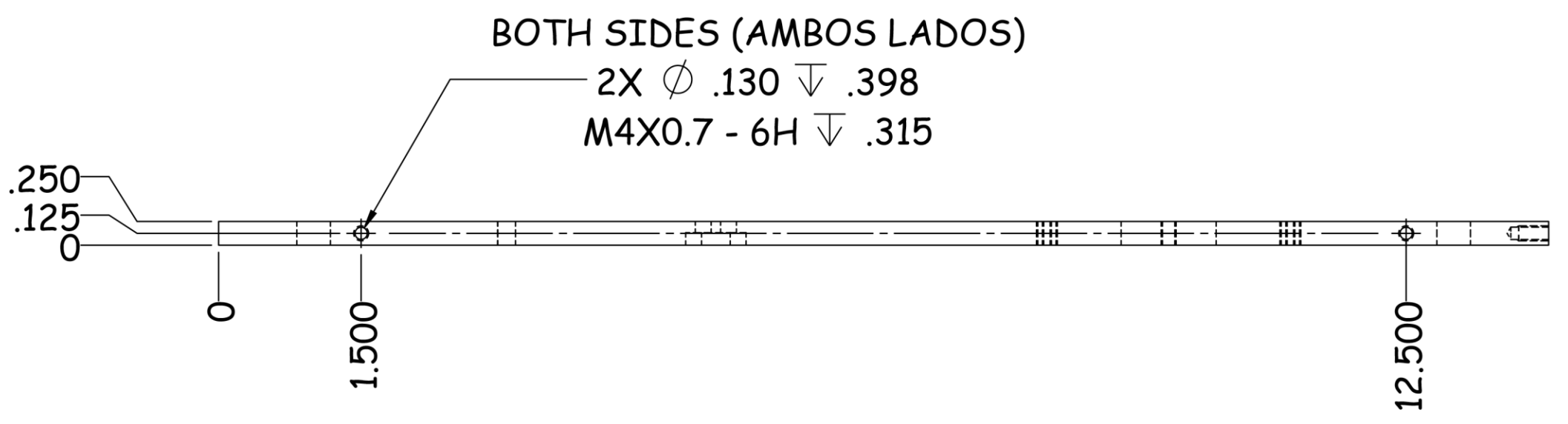

TAG	X LOC	Y LOC	SIZE
A1	1.000	-9.500	$\phi .354$ THRU ALL
A2	1.000	-5.500	
A3	13.000	-9.500	
A4	13.000	-5.500	
B1	5.151	-.386	$\phi .266$ THRU ALL $\square \phi .469 \nabla .132$
B2	5.318	-9.625	
C1	8.688	-5.000	$\phi .130 \nabla .398$ M4X0.7 - 6H $\nabla .315$
C2	10.000	-6.313	
C3	10.000	-3.688	
C4	11.313	-5.000	
D1	8.750	-6.188	$\phi .130$ THRU ALL M4X0.7 - 6H THRU ALL
D2	8.750	-3.813	
D3	11.250	-6.188	
D4	11.250	-3.813	
E1	10.000	-5.000	$\phi 1.000$ THRU ALL

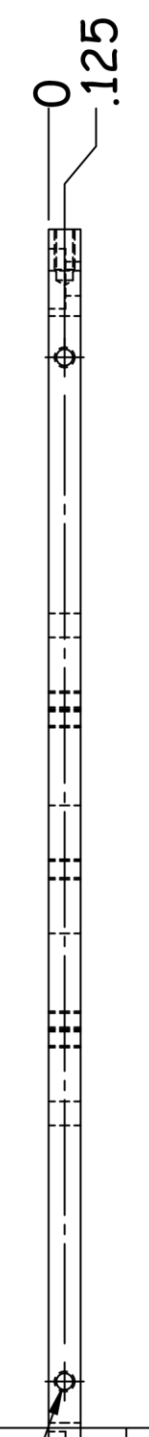

PROJECT	WORK TYPE	H&T				
MR-01	NEW PART	N/A				
STOCK SIZE		CYLINDER STOCK SIZE	DESIGNED BY:	DRAWN BY:	APPROVED BY:	REVIEWED BY:
		N/A	JOSÉ FÉLIX	JOSÉ FÉLIX	JAVIER MOLINA	JAVIER MOLINA

UNLESS OTHERWISE SPECIFIED DIMENSIONS ARE INCH OR [MM].
 TOLERANCE:
 0.0 = $\pm .1$
 0.00 = $\pm .01$
 0.000 = $\pm .001$
 0.0000 = $\pm .0005$
 FRACTIONAL = $\pm .002$
 ANGULAR = $\pm 1^\circ$
 ◆ CRITICAL CHARACTERISTIC

UNIVERSIDAD AUTÓNOMA DE CIUDAD JUÁREZ

KUFFERATH Testing Technology GROUP



REV. No. REVISIONS DATE BY

RELEASED 01/11/2018 JOSÉ FÉLIX

10.000

QTY

PROJECT		WORK TYPE		H&T				
MR-01		NEW PART		N/A				
		STOCK SIZE	CYLINDER STOCK SIZE	DESIGNED BY:	DRAWN BY:	APPROVED BY:	REVIEWED BY:	
				JOSÉ FÉLIX	JOSÉ FÉLIX	JAVIER MOLINA	JAVIER MOLINA	



RELEASED		01/11/2018	JOSÉ FÉLIX
REV. No.	REVISIONS	DATE	BY
		 <small>THIS DRAWING AND INFORMATION CONTAINED HERE ARE EXCLUSIVE PROPERTY OF KUFFERATH AND SHALL BE RETURNED UPON DEMAND AND SHALL NOT BE REPRODUCED IN WHOLE OR IN PARTS.</small>	
		<small>UNLESS OTHERWISE SPECIFIED DIMENSIONS ARE INCH OR [MM].</small> <small>TOLERANCE:</small> <small>0.0 = ± .1</small> <small>0.00 = ± .01</small> <small>0.000 = ± .001</small> <small>0.0000 = ± .0005</small> <small>FRACTIONAL = ± .002</small> <small>ANGULAR = ± 1°</small> <small>◆ CRITICAL CHARACTERISTIC</small>	

2X

QTY



1

PROJECT	WORK TYPE	CYLINDER STOCK SIZE		H&T	DESIGNED BY:		DRAWN BY:	APPROVED BY:	REVIEWED BY:
MR-01	NEW PART	N/A N/A		N/A	JOSÉ FÉLIX		JOSÉ FÉLIX	JAVIER MOLINA	JAVIER MOLINA
STOCK SIZE		CYLINDER STOCK SIZE		DESIGNED BY:		DRAWN BY:	APPROVED BY:	REVIEWED BY:	
		L		JOSÉ FÉLIX		JOSÉ FÉLIX	JAVIER MOLINA	JAVIER MOLINA	
DESCRIPTION		PART NUMBER		TREATMENT					

REV. No.	REVISIONS	RELEASED	DATE	BY
			01/11/2018	JOSÉ FÉLIX
		 <p>THIS DRAWING AND INFORMATION CONTAINED HERE ARE EXCLUSIVE PROPERTY OF KUFFERATH AND SHALL BE RETURNED UPON DEMAND AND SHALL NOT BE REPRODUCED IN WHOLE OR IN PARTS.</p>		
		<p>UNLESS OTHERWISE SPECIFIED DIMENSIONS ARE INCH OR [MM]. TOLERANCE: 0.0 = ± .1 0.00 = ± .01 0.000 = ± .001 0.0000 = ± .0005 FRACTIONAL = ± .002 ANGULAR = ± 1° ◆ CRITICAL CHARACTERISTIC</p>		
				



QTY

PROJECT	WORK TYPE	H&T								
MR-01	NEW PART	N/A								
STOCK SIZE	CYLINDER STOCK SIZE	DESIGNED BY:	DRAWN BY:	APPROVED BY:	REVIEWED BY:					
		JOSÉ FÉLIX	JOSÉ FÉLIX	JAVIER MOLINA	JAVIER MOLINA					
6	5	7	MR-01-015	4	6	ANODIZED	2	4	1	3

REV. No.	REVISIONS	DATE	BY
		01/11/2018	JOSÉ FÉLIX
		 <p>THIS DRAWING AND INFORMATION CONTAINED HERE ARE EXCLUSIVE PROPERTY OF KUFFERATH AND SHALL BE RETURNED UPON DEMAND AND SHALL NOT BE REPRODUCED IN WHOLE OR IN PARTS.</p>	
		<p>UNLESS OTHERWISE SPECIFIED DIMENSIONS ARE INCH OR [MM]. TOLERANCE: 0.0 = ± .1 0.00 = ± .01 0.000 = ± .001 0.0000 = ± .0005 FRACTIONAL = ± .002 ANGULAR = ± 1° ◆ CRITICAL CHARACTERISTIC</p>	

QTY

1

RELEASED		011/11/2018	JOSÉ FÉLIX
REV. No.	REVISIONS	DATE	BY
		 THIRD ANGLE PROJECTION	<small>THIS DRAWING AND INFORMATION CONTAINED HERE ARE EXCLUSIVE PROPERTY OF KUFFERATH AND SHALL BE RETURNED UPON DEMAND AND SHALL NOT BE REPRODUCED IN WHOLE OR IN PARTS.</small>
			

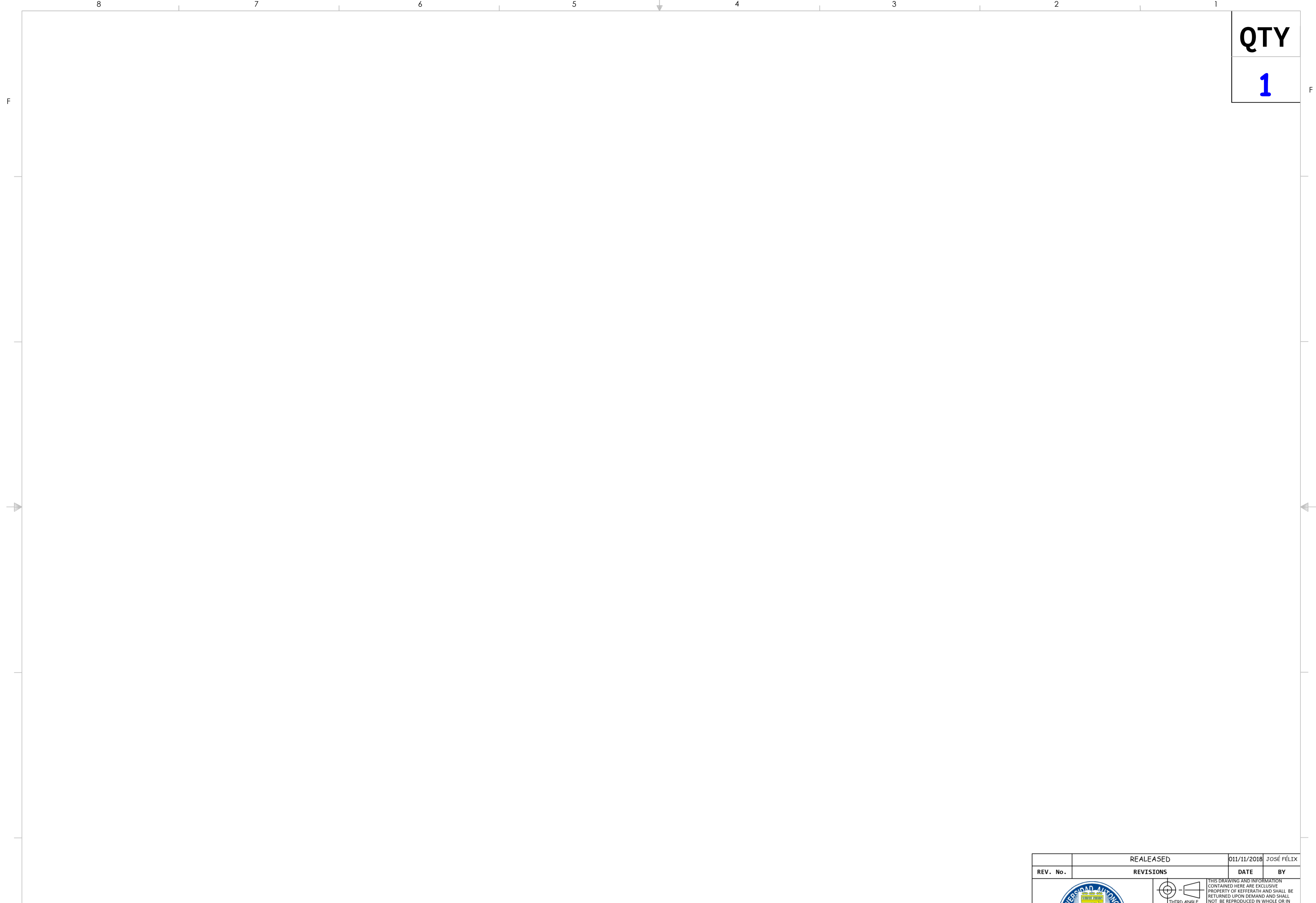

PROJECT	WORK TYPE	CYLINDER STOCK SIZE		DESIGNED BY:	DRAWN BY:	APPROVED BY:	REVIEWED BY:
MR-01	NEW PART	N/A		JOSÉ FÉLIX	JOSÉ FÉLIX	JAVIER MOLINA	JAVIER MOLINA
STOCK SIZE		CYLINDER STOCK SIZE					
		L					
		N/A					

MATERIAL



QTY

PROJECT	WORK TYPE	H&T
MR-01	NEW PART	N/A
	STOCK SIZE	CYLINDER STOCK SIZE
	DESIGNED BY:	DRAWN BY:
	JOSÉ FÉLIX	JOSÉ FÉLIX
	APPROVED BY:	REVIEWED BY:
	JAVIER MOLINA	JAVIER MOLINA

REV. No.	REVISIONS	DATE	BY
		01/11/2018	JOSÉ FÉLIX
		 <p>THIS DRAWING AND INFORMATION CONTAINED HERE ARE EXCLUSIVE PROPERTY OF KUFFERATH AND SHALL BE RETURNED UPON DEMAND AND SHALL NOT BE REPRODUCED IN WHOLE OR IN PARTS.</p>	
		<p>UNLESS OTHERWISE SPECIFIED DIMENSIONS ARE INCH OR [MM]. TOLERANCE: 0.0 = ± .1 0.00 = ± .01 0.000 = ± .001 0.0000 = ± .0005 FRACTIONAL = ± .002 ANGULAR = ± 1° ◆ CRITICAL CHARACTERISTIC</p>	

QTY

1

PROJECT	WORK TYPE	CYLINDER STOCK SIZE		DESIGNED BY:	DRAWN BY:	APPROVED BY:	REVIEWED BY:
MR-01	NEW PART	N/A	N/A	JOSÉ FÉLIX	JOSÉ FÉLIX	JAVIER MOLINA	JAVIER MOLINA

ALUMINUM 6061

REV. No.	REVISIONS	DATE	BY
		01/11/2018	JOSÉ FÉLIX

RELEASED





THIS DRAWING AND INFORMATION CONTAINED HERE ARE EXCLUSIVE PROPERTY OF KUFFERATH AND SHALL BE RETURNED UPON DEMAND AND SHALL NOT BE REPRODUCED IN WHOLE OR IN PARTS.

KUFFERATH
Testing Technology GROUP

UNLESS OTHERWISE SPECIFIED DIMENSIONS ARE INCH OR [MM].
 TOLERANCE:
 0.0 = ± .1
 0.00 = ± .01
 0.000 = ± .001
 0.0000 = ± .0005
 FRACTIONAL = ± .002
 ANGULAR = ± 1°
 ◆ CRITICAL CHARACTERISTIC

QTY

PROJECT	WORK TYPE	H&T
MR-01	NEW PART	N/A
	STOCK SIZE	CYLINDER STOCK SIZE
	DESIGNED BY:	DRAWN BY:
	JOSÉ FÉLIX	JOSÉ FÉLIX
	APPROVED BY:	REVIEWED BY:
	JAVIER MOLINA	JAVIER MOLINA

REV. No.	REVISIONS	DATE	BY
		01/11/2018	JOSÉ FÉLIX
		 <p>THIS DRAWING AND INFORMATION CONTAINED HERE ARE EXCLUSIVE PROPERTY OF KUFFERATH AND SHALL BE RETURNED UPON DEMAND AND SHALL NOT BE REPRODUCED IN WHOLE OR IN PARTS.</p>	
		<p>UNLESS OTHERWISE SPECIFIED DIMENSIONS ARE INCH OR [MM]. TOLERANCE: 0.0 = ± .1 0.00 = ± .01 0.000 = ± .001 0.0000 = ± .0005 FRACTIONAL = ± .002 ANGULAR = ± 1° ◆ CRITICAL CHARACTERISTIC</p>	

1/4" 10" 7 16"

4 6 3 5

2 4

1 3

2

1

F

F

A

QTY

1

4

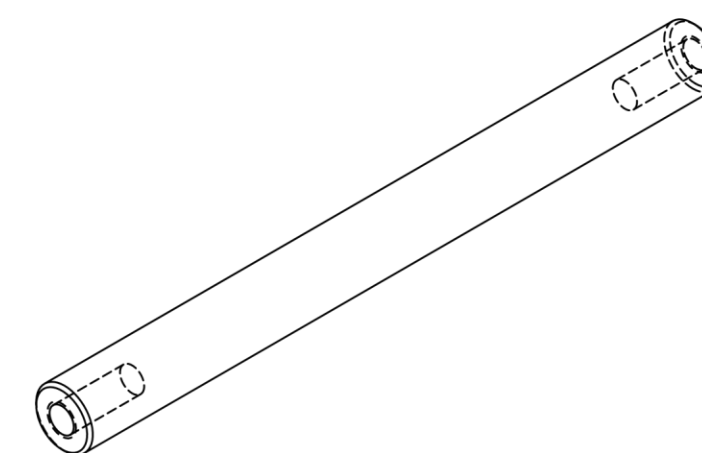

BOTH SIDES (AMBOS LADOS)

ϕ .268 .778
M8X1.25 - 6H .630

ϕ $\frac{5}{8}$

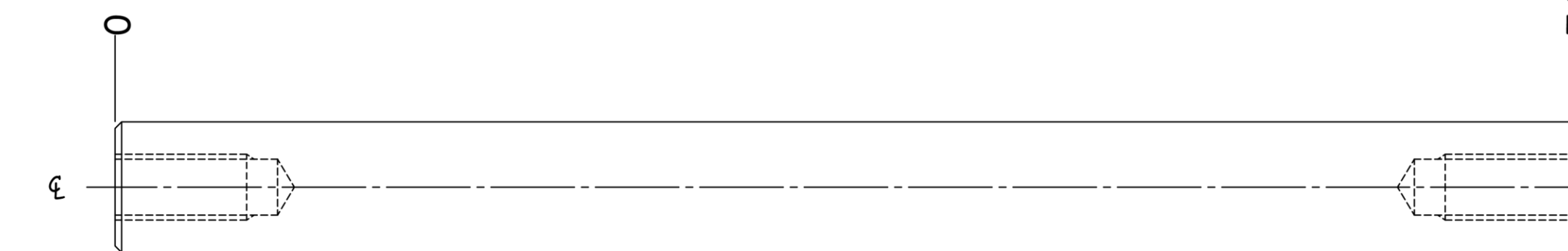
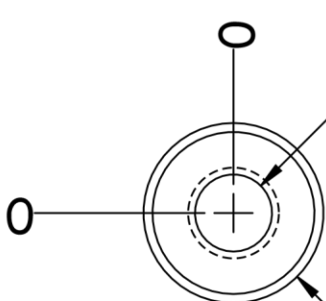

7.000

2X $\frac{1}{32}$ " X 45.0°

\square .001

A

\parallel .001 A

PROJECT	WORK TYPE	H&T
MR-01	NEW PART	N/A
DESIGNED BY:	DRAWN BY:	APPROVED BY:
JOSÉ FÉLIX	JOSÉ FÉLIX	JAVIER MOLINA
REVIEWED BY:		
JAVIER MOLINA		

REV. No.	REVISIONS	DATE	BY
2		01/11/2018	JOSÉ FÉLIX

UNLESS OTHERWISE SPECIFIED DIMENSIONS ARE INCH OR [MM].
TOLERANCE:
0.0 = ±.1
0.00 = ±.01
0.000 = ±.001
0.0000 = ±.0005
FRACTIONAL = ±.002
ANGULAR = ±.1°
◆ CRITICAL CHARACTERISTIC



KUFFERATH
Testing Technology GROUP

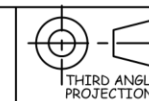

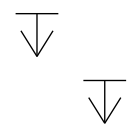

THIS DRAWING AND INFORMATION CONTAINED HERE ARE EXCLUSIVE PROPERTY OF KUFFERATH AND SHALL BE RETURNED UPON DEMAND AND SHALL NOT BE REPRODUCED IN WHOLE OR IN PARTS.

QTY



PROJECT	WORK TYPE	H&T						
MR-01	NEW PART	N/A						
	STOCK SIZE	CYLINDER STOCK SIZE	DESIGNED BY:	DRAWN BY:	APPROVED BY:	REVIEWED BY:	TITLE	
			JOSÉ FÉLIX	JOSÉ FÉLIX	JAVIER MOLINA	JAVIER MOLINA		

RELEASED		011/11/2018	JOSÉ FÉLIX
REV. No.	REVISIONS	DATE	BY
		 <small>THIS DRAWING AND INFORMATION CONTAINED HERE ARE EXCLUSIVE PROPERTY OF KUFFERATH AND SHALL BE RETURNED UPON DEMAND AND SHALL NOT BE REPRODUCED IN WHOLE OR IN PARTS.</small>	
		<small>UNLESS OTHERWISE SPECIFIED DIMENSIONS ARE INCH OR [MM].</small> <small>TOLERANCE:</small> <small>0.0 = ± .1</small> <small>0.00 = ± .01</small> <small>0.000 = ± .001</small> <small>0.0000 = ± .0005</small> <small>FRACTIONAL = ± .002</small> <small>ANGULAR = ± 1°</small> <small>◆ CRITICAL CHARACTERISTIC</small>	
			

QTY

1

PROJECT		WORK TYPE		H&T					
MR-01		NEW PART		N/A					
		STOCK SIZE		DESIGNED BY:	DRAWN BY:	APPROVED BY:	REVIEWED BY:		MR-01-
				JOSÉ FÉLIX	JOSÉ FÉLIX	JAVIER MOLINA	JAVIER MOLINA		

	RELEASED	011/11/2018	JOSÉ FÉLIX
REV. No.	REVISIONS	DATE	BY



KUFFERATH
Testing Technology GROUP



THIRD ANGLE PROJECTION

THIS DRAWING AND INFORMATION CONTAINED HERE ARE EXCLUSIVE PROPERTY OF KUFFERATH AND SHALL BE RETURNED UPON DEMAND AND SHALL NOT BE REPRODUCED IN WHOLE OR IN PARTS.

UNLESS OTHERWISE SPECIFIED DIMENSIONS ARE INCH OR [MM].
TOLERANCE:
0.0 = ± .1
0.00 = ± .01
0.000 = ± .001
0.0000 = ± .0005
FRACTIONAL = ± .002
ANGULAR = ± 1°
◆ CRITICAL CHARACTERISTIC

QTY



PROJECT	WORK TYPE	H&T					
MR-01	NEW PART	N/A					
	STOCK SIZE	CYLINDER STOCK SIZE	DESIGNED BY:	DRAWN BY:	APPROVED BY:	REVIEWED BY:	016
			JOSÉ FÉLIX	JOSÉ FÉLIX	JAVIER MOLINA	JAVIER MOLINA	

REV. No.	REVISIONS	DATE	BY
		011/11/2018	JOSÉ FÉLIX
		 <p>THIS DRAWING AND INFORMATION CONTAINED HERE ARE EXCLUSIVE PROPERTY OF KUFFERATH AND SHALL BE RETURNED UPON DEMAND AND SHALL NOT BE REPRODUCED IN WHOLE OR IN PARTS.</p>	
		<p>UNLESS OTHERWISE SPECIFIED DIMENSIONS ARE INCH OR [MM]. TOLERANCE: 0.0 = ± .1 0.00 = ± .01 0.000 = ± .001 0.0000 = ± .0005 FRACTIONAL = ± .002 ANGULAR = ± 1° ◆ CRITICAL CHARACTERISTIC</p>	

QTY



2

PROJECT		WORK TYPE		H&T	TREATMENT				
MR-01		NEW PART		N/A	N/A				
	7.250	STOCK SIZE	CYLINDER STOCK SIZE	DESIGNED BY:	DRAWN BY:	APPROVED BY:	REVIEWED BY:		
	0		L N/A N/A	JOSÉ FÉLIX	JOSÉ FÉLIX	JAVIER MOLINA	JAVIER MOLINA		

REV. No.		REVISIONS		RELEASED	011/11/2018	JOSÉ FÉLIX
				 		
				<p>THIS DRAWING AND INFORMATION CONTAINED HERE ARE EXCLUSIVE PROPERTY OF KUPFERATH AND SHALL BE RETURNED UPON DEMAND AND SHALL NOT BE REPRODUCED IN WHOLE OR IN PARTS.</p> <p>UNLESS OTHERWISE SPECIFIED DIMENSIONS ARE INCH OR [MM].</p> <p>TOLERANCE:</p> <p>0.0 = ± .1</p> <p>0.00 = ± .01</p> <p>0.000 = ± .001</p> <p>0.0000 = ± .0005</p> <p>FRACTIONAL = ± .002</p> <p>ANGULAR = ± 1°</p> <p>◆ CRITICAL CHARACTERISTIC</p>		

QTY

PROJECT	WORK TYPE	CYLINDER STOCK SIZE		H&T	TREATMENT	FINISH	
MR-01	NEW PART			N/A	N/A	MILLING	
STOCK SIZE		DESIGNED BY:	DRAWN BY:	APPROVED BY:	REVIEWED BY:		
.165		JOSÉ FÉLIX	JOSÉ FÉLIX	JAVIER MOLINA	JAVIER MOLINA		
						Ø	L
		N/A	N/A				

RELEASED		011/11/2018	JOSÉ FÉLIX
REV. No.	REVISIONS	DATE	BY
		 <small>THIS DRAWING AND INFORMATION CONTAINED HERE ARE EXCLUSIVE PROPERTY OF KUFFERATH AND SHALL BE RETURNED UPON DEMAND AND SHALL NOT BE REPRODUCED IN WHOLE OR IN PARTS.</small>	
		<small>UNLESS OTHERWISE SPECIFIED DIMENSIONS ARE INCH OR [MM].</small> <small>TOLERANCE:</small> <small>0.0 = ± .1</small> <small>0.00 = ± .01</small> <small>0.000 = ± .001</small> <small>0.0000 = ± .0005</small> <small>FRACTIONAL = ± .002</small> <small>ANGULAR = ± 1°</small> <small>◆ CRITICAL CHARACTERISTIC</small>	
			

QTY

1

7.250

.125
0

0

1.165

9.165

10.330

2X \varnothing .177 THRU ALL

DESCRIPTION PART NUMBER TAPA LATERAL MR-01-017

MATERIAL

ALUCOMEX

THK	W	L	\varnothing
.165"	7 1/4"	16"	

0

.165

MATERIAL		STOCK SIZE		CYLINDER STOCK SIZE		DESIGNED BY:	DRAWN BY:	APPROVED BY:	REVIEWED BY:
				N/A	N/A	JOSÉ FÉLIX	JOSÉ FÉLIX	JAVIER MOLINA	JAVIER MOLINA

H&T

N/A

TREATMENT

N/A

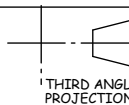



THIS DRAWING AND INFORMATION CONTAINED HERE ARE EXCLUSIVE PROPERTY OF KEPPERATH AND SHALL BE RETURNED UPON DEMAND AND SHALL NOT BE REPRODUCED IN WHOLE OR IN PARTS.

UNLESS OTHERWISE SPECIFIED DIMENSIONS ARE INCH OR [MM].
 TOLERANCE:
 0.0 = \pm .1
 0.00 = \pm .01
 0.000 = \pm .001
 0.0000 = \pm .0005
 FRACTIONAL = \pm .002
 ANGULAR = \pm 1
 ◆ CRITICAL CHARACTERISTIC

DATE	BY
	JOSÉ FÉLIX

QTY

PROJECT	WORK TYPE	H&T	TREATMENT	FINISH		
MR-01	NEW PART	N/A	N/A	MILLING		
DESCRIPTION	STOCK SIZE PART NUMBER	CYLINDER STOCK SIZE	DESIGNED BY:	DRAWN BY:	APPROVED BY:	REVIEWED BY:
	TAPA FRONTAL	MR-01-018	JOSÉ FÉLIX	JOSÉ FÉLIX	JAVIER MOLINA	JAVIER MOLINA
		N/A				

REV. No.	REVISIONS	DATE	BY
		01/11/2018	JOSÉ FÉLIX
		 <p>THIS DRAWING AND INFORMATION CONTAINED HERE ARE EXCLUSIVE PROPERTY OF KUFFERATH AND SHALL BE RETURNED UPON DEMAND AND SHALL NOT BE REPRODUCED IN WHOLE OR IN PARTS.</p>	
		<p>UNLESS OTHERWISE SPECIFIED DIMENSIONS ARE INCH OR [MM]. TOLERANCE: 0.0 = ± .1 0.00 = ± .01 0.000 = ± .001 0.0000 = ± .0005 FRACTIONAL = ± .002 ANGULAR = ± 1° ◆ CRITICAL CHARACTERISTIC</p>	

F

MATERIAL
 ALUCOMEX
 THK W L
 .165" 7 1/4" 10 3/8"

TITLE
 MR-01-018

MATERIAL		STOCK SIZE		CYLINDER STOCK SIZE		DESIGNED BY:	DRAWN BY:	APPROVED BY:	REVIEWED BY:
				N/A	L N/A	JOSÉ FÉLIX	JOSÉ FÉLIX	JAVIER MOLINA	JAVIER MOLINA

H&T
N/A
TREATMENT
N/A

JOSÉ FÉLIX

DATE	BY

THIS DRAWING AND INFORMATION CONTAINED HERE ARE EXCLUSIVE PROPERTY OF KEPPERATH AND SHALL BE RETURNED UPON DEMAND AND SHALL NOT BE REPRODUCED IN WHOLE OR IN PARTS.

THIRD ANGLE PROJECTION

UNLESS OTHERWISE SPECIFIED DIMENSIONS ARE INCH OR [MM].
 TOLERANCE:
 0.0 = ± .1
 0.00 = ± .01
 0.000 = ± .001
 0.0000 = ± .0005
 FRACTIONAL = ± .002
 ANGULAR = ± 1
 ♦ CRITICAL CHARACTERISTIC

QTY

1

PROJECT	WORK TYPE	H&T	TREATMENT	FINISH
MR-01	NEW PART	N/A	N/A	MILLING
STOCK SIZE		DESIGNED BY:	DRAWN BY:	APPROVED BY:
CYLINDER STOCK SIZE		JOSÉ FÉLIX	JOSÉ FÉLIX	JAVIER MOLINA
Ø	L6			
N/A	N/A			

REV. No.	REVISIONS	DATE	BY
		01/11/2018	JOSÉ FÉLIX

UNLESS OTHERWISE SPECIFIED
 DIMENSIONS ARE INCH OR [MM].
 DECIMAL = ± .01
 .000 = ± .001
 0.0000 = ± .0005
 FRACTIONAL = ± .002
 ANGULAR = ± 1°
 ◆ CRITICAL CHARACTERISTIC

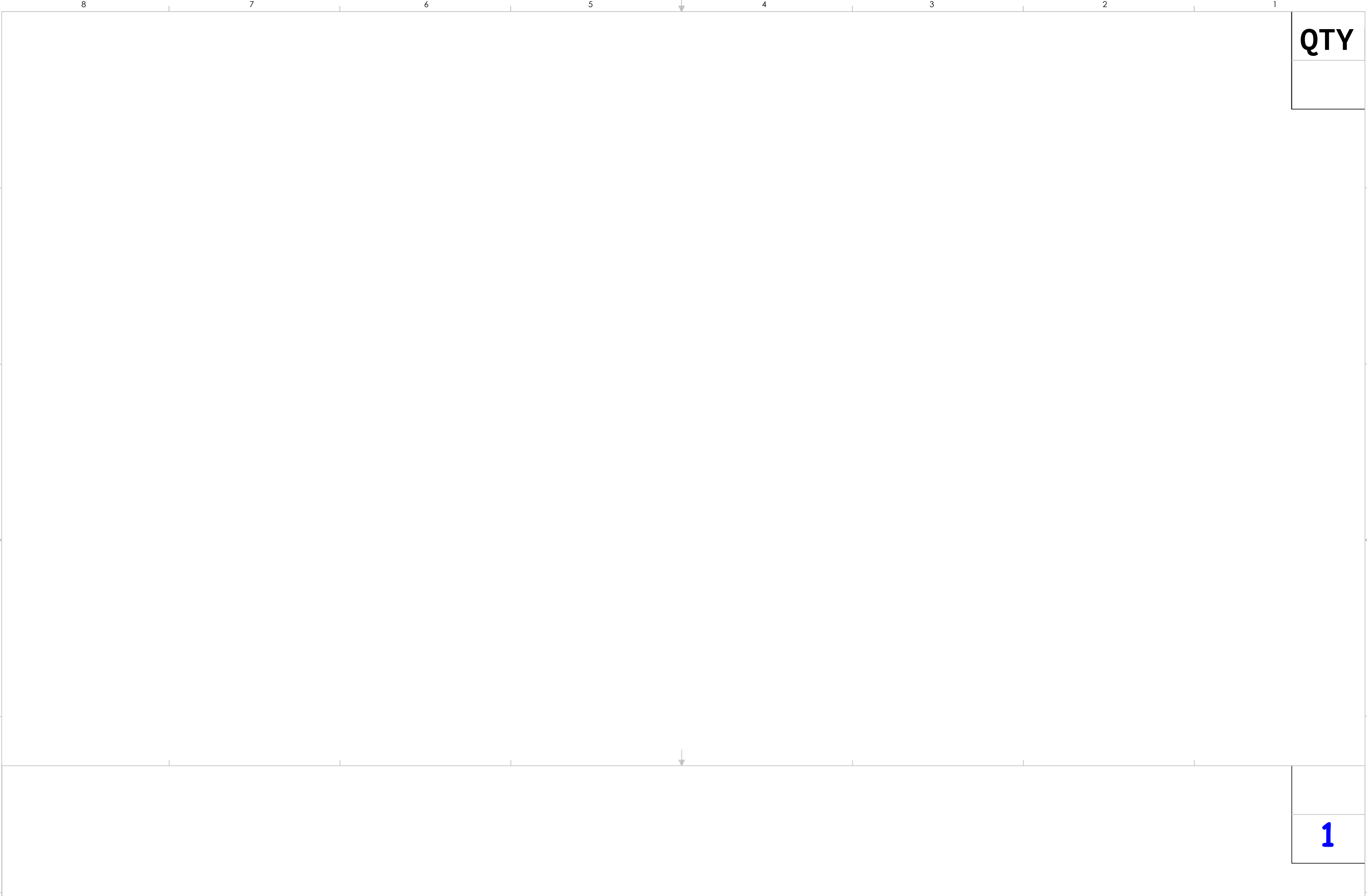
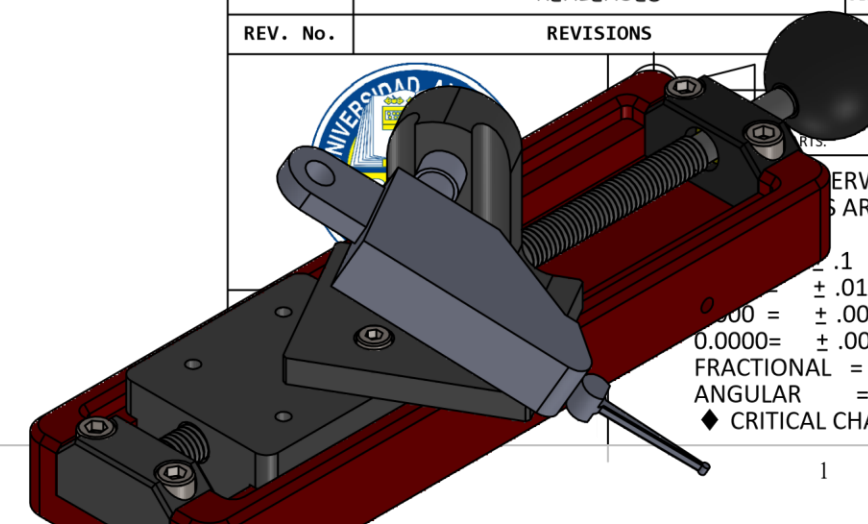

QTY
1

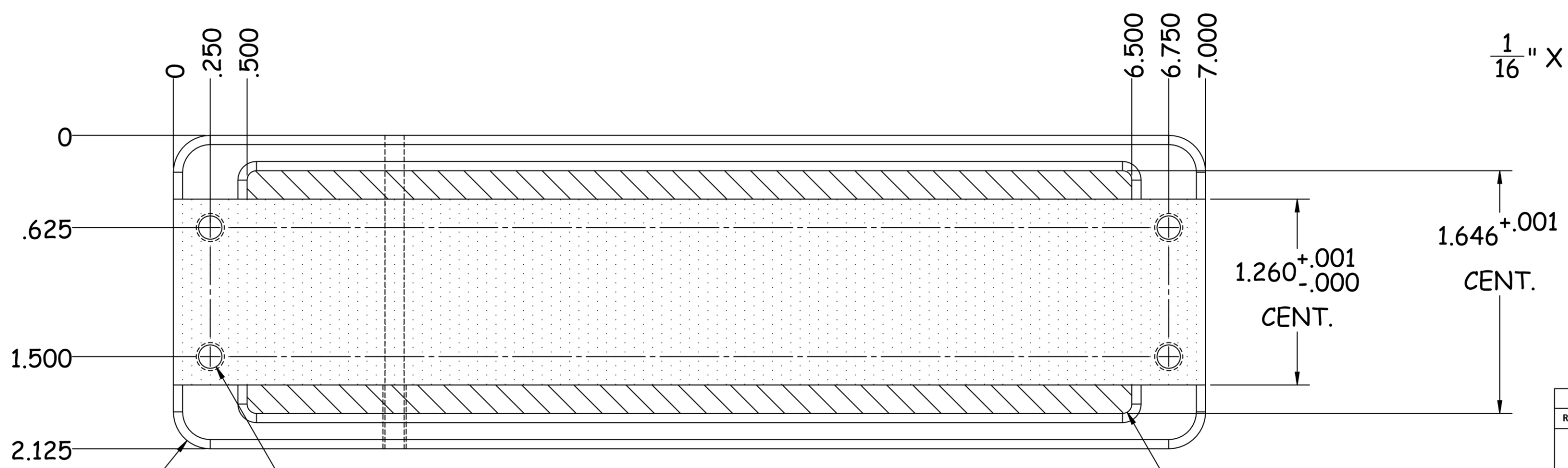
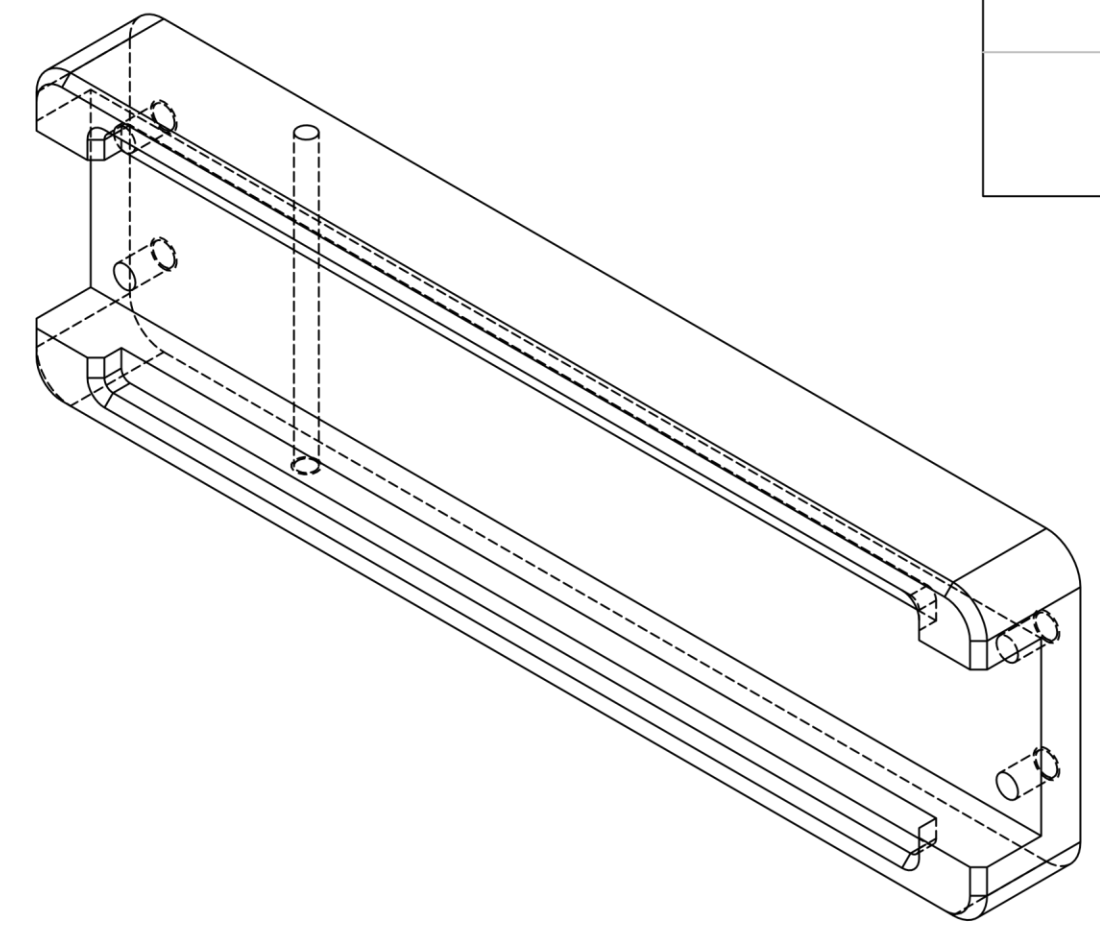
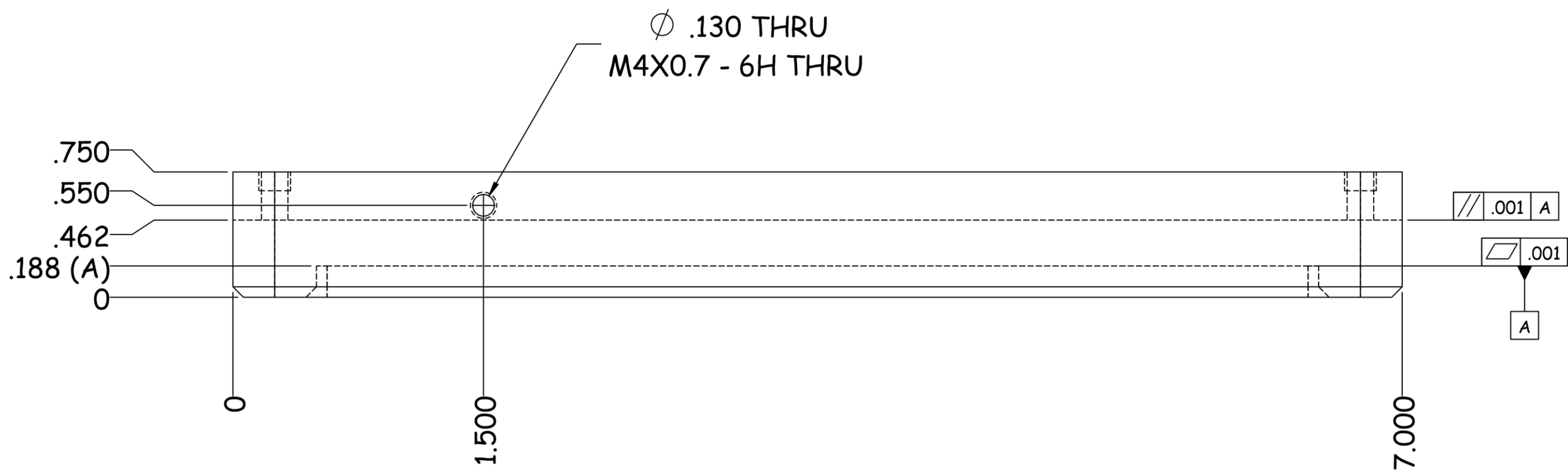

REV. No.	REVISIONS	DATE	BY
		01/11/2018	JOSÉ FÉLIX

UNLESS OTHERWISE SPECIFIED DIMENSIONS ARE INCH OR [MM].
 TOLERANCE:
 0.0 = $\pm .1$
 0.00 = $\pm .01$
 0.000 = $\pm .001$
 0.0000 = $\pm .0005$
 FRACTIONAL = $\pm .002$
 ANGULAR = $\pm 1^\circ$
 ◆ CRITICAL CHARACTERISTIC



PROJECT	MR-03	WORK TYPE	NEW PART	H&T	N/A	FINISH	MILLING
MATERIAL	ALUMINUM TOOLING PLATE	STOCK SIZE		DESIGNED BY:	JOSÉ FÉLIX	DRAWN BY:	JOSÉ FÉLIX
		CYLINDER STOCK SIZE	\varnothing N/A, L N/A	APPROVED BY:	JAVIER MOLINA	REVIEWED BY:	JAVIER MOLINA

QTY

1

PROJECT	WORK TYPE	H&T	FINISH			
MR-03	NEW PART	N/A	MILLING			
MATERIAL	STOCK SIZE	CYLINDER STOCK SIZE	DESIGNED BY:	DRAWN BY:	APPROVED BY:	REVIEWED BY:
ALUMINUM TOOLING PLATE		\varnothing	JOSÉ FÉLIX	JOSÉ FÉLIX	JAVIER MOLINA	JAVIER MOLINA
		L				
		N/A				

.159 THRU ALL

RELEASED		JOSÉ FÉLIX
REV. No.	REVISIONS	DATE BY
		 <p>THIS DRAWING AND INFORMATION CONTAINED HERE ARE EXCLUSIVE PROPERTY OF KUFFERATH AND SHALL BE RETURNED UPON DEMAND AND SHALL NOT BE REPRODUCED IN WHOLE OR IN PARTS.</p> <p>UNLESS OTHERWISE SPECIFIED DIMENSIONS ARE INCH OR [MM]. TOLERANCE: 0.0 = ± .1 0.00 = ± .01 0.000 = ± .001 0.0000 = ± .0005 FRACTIONAL = ± .002 ANGULAR = ± 1° ◆ CRITICAL CHARACTERISTIC</p>
		

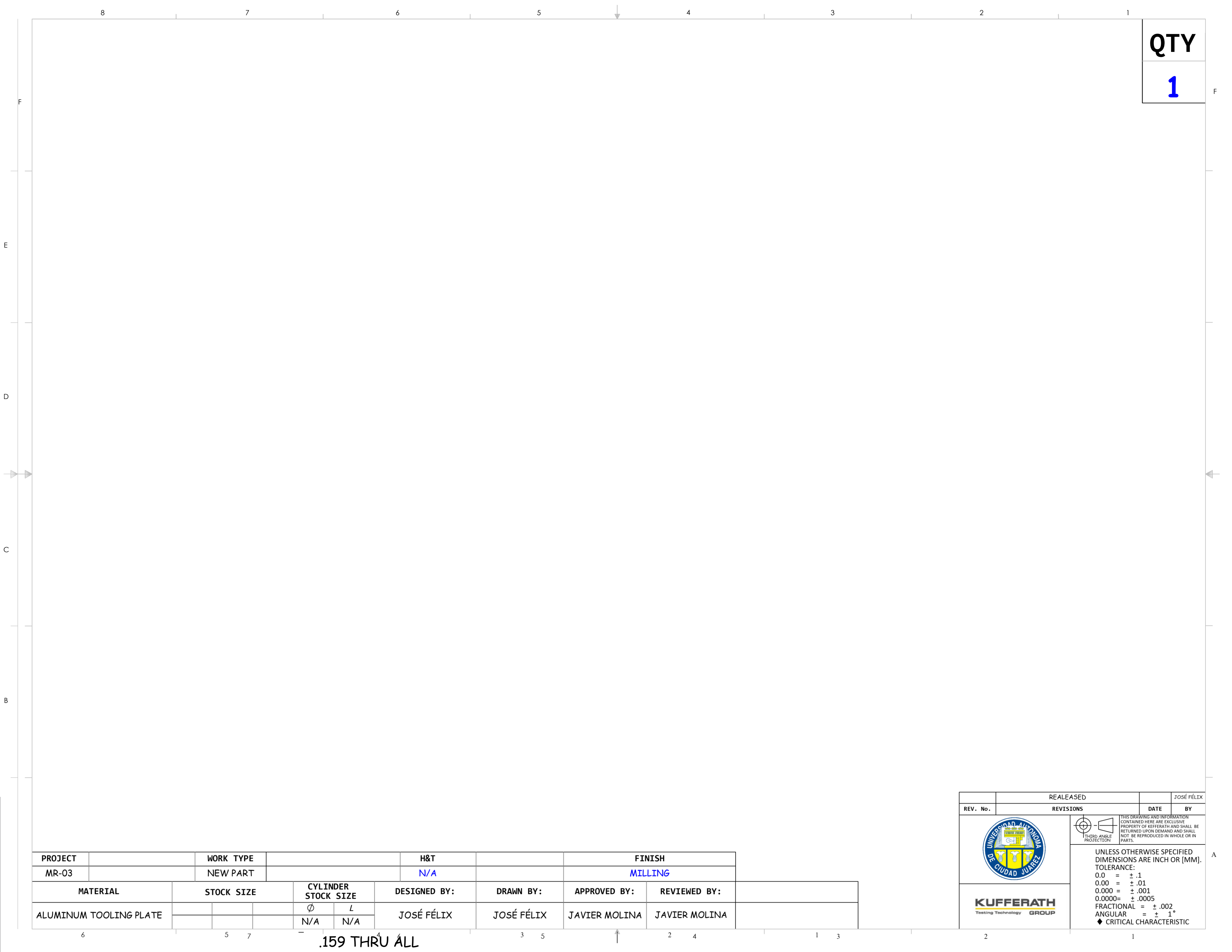

QTY

F

F

8

7

6

5

4

3

2



1

→

←

		WORK TYPE		H&T		FINISH		
		NEW PART		N/A		MILLING		
MATERIAL	STOCK SIZE		CYLINDER STOCK SIZE		DESIGNED BY:	DRAWN BY:	APPROVED BY:	REVIEWED BY:
ALUMINUM TOOLING PLATE			∅	L	JOSÉ FÉLIX	JOSÉ FÉLIX	JAVIER MOLINA	JAVIER MOLINA
			N/A	N/A				

10-32 UNF THRU ALL

	RELEASED	011/11/2018	JOSÉ FÉLIX
REV. No.	REVISIONS	DATE	BY
		 <p>THIS DRAWING AND INFORMATION CONTAINED HERE ARE EXCLUSIVE PROPERTY OF KUFFERATH AND SHALL BE RETURNED UPON DEMAND AND SHALL NOT BE REPRODUCED IN WHOLE OR IN PARTS.</p>	
		<p>UNLESS OTHERWISE SPECIFIED DIMENSIONS ARE INCH OR [MM]. TOLERANCE: 0.0 = ± .1 0.00 = ± .01 0.000 = ± .001 0.0000 = ± .0005 FRACTIONAL = ± .002 ANGULAR = ± 1° ◆ CRITICAL CHARACTERISTIC</p>	



A

6 5 7 4 6 3 5 2 4 1 3 2 1

QTY

1

PROJECT	WORK TYPE	CYLINDER STOCK SIZE		H&T	FINISH			
MR-03	NEW PART			N/A	MILLING			
MATERIAL	STOCK SIZE	CYLINDER STOCK SIZE		DESIGNED BY:	DRAWN BY:	APPROVED BY:	REVIEWED BY:	
ALUMINUM TOOLING PLATE		Ø	L	JOSÉ FÉLIX	JOSÉ FÉLIX	JAVIER MOLINA	JAVIER MOLINA	
		N/A	N/A					
6 DESCRIPTION	5 7	PART NUMBER 4 6		TREATMENT		2 4		

REV. No.		RELEASED	DATE	BY
				JOSÉ FÉLIX
		 <p>THIS DRAWING AND INFORMATION CONTAINED HERE ARE EXCLUSIVE PROPERTY OF KUFFERATH AND SHALL BE RETURNED UPON DEMAND AND SHALL NOT BE REPRODUCED IN WHOLE OR IN PARTS.</p>		
		<p>UNLESS OTHERWISE SPECIFIED DIMENSIONS ARE INCH OR [MM]. TOLERANCE: 0.0 = ± .1 0.00 = ± .01 0.000 = ± .001 0.0000 = ± .0005 FRACTIONAL = ± .002 ANGULAR = ± 1° ◆ CRITICAL CHARACTERISTIC</p>		

QTY

F

F

8

7

6

5

4

3

2

1

→

←

		WORK TYPE		H&T		FINISH	
		NEW PART		N/A		MILLING	
MATERIAL	STOCK SIZE	CYLINDER STOCK SIZE		DESIGNED BY:	DRAWN BY:	APPROVED BY:	REVIEWED BY:
ALUMINUM TOOLING PLATE		∅	L	JOSÉ FÉLIX	JOSÉ FÉLIX	JAVIER MOLINA	JAVIER MOLINA
		N/A	N/A				

6

5

7

4

6

3

5

2

4

TITLE

1

3



KUFFERATH
Testing Technology GROUP



THIS DRAWING AND INFORMATION CONTAINED HERE ARE EXCLUSIVE PROPERTY OF KUFFERATH AND SHALL BE RETURNED UPON DEMAND AND SHALL NOT BE REPRODUCED IN WHOLE OR IN PARTS.

UNLESS OTHERWISE SPECIFIED DIMENSIONS ARE INCH OR [MM].
TOLERANCE:
 0.0 = ± .1
 0.00 = ± .01
 0.000 = ± .001
 0.0000 = ± .0005
 FRACTIONAL = ± .002
 ANGULAR = ± 1°
 ◆ CRITICAL CHARACTERISTIC

	RELEASED	011/11/2018	JOSÉ FÉLIX
REV. No.	REVISIONS	DATE	BY



A

1



QTY

1

PROJECT		WORK TYPE		H&T		FINISH		
MR-03		NEW PART		N/A		MILLING		
MATERIAL	STOCK SIZE		CYLINDER STOCK SIZE		DESIGNED BY:	DRAWN BY:	APPROVED BY:	REVIEWED BY:
ALUMINUM TOOLING PLATE			∅	L	JOSÉ FÉLIX	JOSÉ FÉLIX	JAVIER MOLINA	JAVIER MOLINA
			N/A	N/A				

	RELEASED		JOSÉ FÉLIX
REV. No.	REVISIONS	DATE	BY
		 <p>THIS DRAWING AND INFORMATION CONTAINED HERE ARE EXCLUSIVE PROPERTY OF KUFFERATH AND SHALL BE RETURNED UPON DEMAND AND SHALL NOT BE REPRODUCED IN WHOLE OR IN PARTS.</p>	
		<p>UNLESS OTHERWISE SPECIFIED DIMENSIONS ARE INCH OR [MM]. TOLERANCE: 0.0 = ± .1 0.00 = ± .01 0.000 = ± .001 0.0000 = ± .0005 FRACTIONAL = ± .002 ANGULAR = ± 1° ◆ CRITICAL CHARACTERISTIC</p>	

QTY

RELEASED		011/11/2018	JOSÉ FÉLIX
REV. No.	REVISIONS	DATE	BY
		 <small>THIS DRAWING AND INFORMATION CONTAINED HERE ARE EXCLUSIVE PROPERTY OF KUFFERATH AND SHALL BE RETURNED UPON DEMAND AND SHALL NOT BE REPRODUCED IN WHOLE OR IN PARTS.</small>	
		<small>UNLESS OTHERWISE SPECIFIED DIMENSIONS ARE INCH OR [MM].</small> <small>TOLERANCE:</small> <small>0.0 = ± .1</small> <small>0.00 = ± .01</small> <small>0.000 = ± .001</small> <small>0.0000 = ± .0005</small> <small>FRACTIONAL = ± .002</small> <small>ANGULAR = ± 1°</small> <small>◆ CRITICAL CHARACTERISTIC</small>	
			

		WORK TYPE		H&T		FINISH	
		NEW PART		N/A		MILLING	
MATERIAL	STOCK SIZE	CYLINDER STOCK SIZE		DESIGNED BY:	DRAWN BY:	APPROVED BY:	REVIEWED BY:
ALUMINUM TOOLING PLATE		∅	L	JOSÉ FÉLIX	JOSÉ FÉLIX	JAVIER MOLINA	JAVIER MOLINA
		N/A	N/A				

MR-02-001 3



QTY

1

PROJECT		WORK TYPE		H&T		FINISH		
MR-03		NEW PART		N/A		MILLING		
MATERIAL	STOCK SIZE		CYLINDER STOCK SIZE		DESIGNED BY:	DRAWN BY:	APPROVED BY:	REVIEWED BY:
ALUMINUM TOOLING PLATE			\varnothing	L	JOSÉ FÉLIX	JOSÉ FÉLIX	JAVIER MOLINA	JAVIER MOLINA
	3/4"	2 1/8" 7"	N/A	N/A				

	RELEASED	JOSÉ FÉLIX
REV. No.	REVISIONS	DATE BY



KUFFERATH
Testing Technology GROUP

THIRD ANGLE PROJECTION



THIS DRAWING AND INFORMATION CONTAINED HERE ARE EXCLUSIVE PROPERTY OF KUFFERATH AND SHALL BE RETURNED UPON DEMAND AND SHALL NOT BE REPRODUCED IN WHOLE OR IN PARTS.

UNLESS OTHERWISE SPECIFIED DIMENSIONS ARE INCH OR [MM].
TOLERANCE:
0.0 = ± .1
0.00 = ± .01
0.000 = ± .001
0.0000 = ± .0005
FRACTIONAL = ± .002
ANGULAR = ± 1°
◆ CRITICAL CHARACTERISTIC

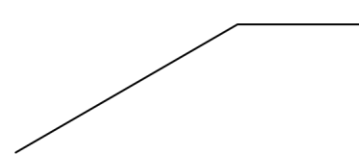
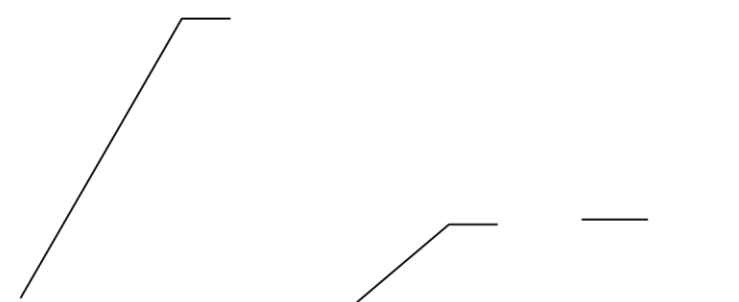
QTY





		WORK TYPE		H&T		FINISH		
		NEW PART		N/A		MILLING		
MATERIAL	STOCK SIZE		CYLINDER STOCK SIZE		DESIGNED BY:	DRAWN BY:	APPROVED BY:	REVIEWED BY:
ALUMINUM TOOLING PLATE			∅	L	JOSÉ FÉLIX	JOSÉ FÉLIX	JAVIER MOLINA	JAVIER MOLINA
			N/A	N/A				

	RELEASED	011/11/2018	JOSÉ FÉLIX
REV. No.	REVISIONS	DATE	BY
			
		<p>THIS DRAWING AND INFORMATION CONTAINED HERE ARE EXCLUSIVE PROPERTY OF KUFFERATH AND SHALL BE RETURNED UPON DEMAND AND SHALL NOT BE REPRODUCED IN WHOLE OR IN PARTS.</p> <p>UNLESS OTHERWISE SPECIFIED DIMENSIONS ARE INCH OR [MM]. TOLERANCE: 0.0 = ± .1 0.00 = ± .01 0.000 = ± .001 0.0000 = ± .0005 FRACTIONAL = ± .002 ANGULAR = ± 1° ◆ CRITICAL CHARACTERISTIC</p>	

QTY

1

PROJECT	WORK TYPE	H&T	FINISH
MR-03	NEW PART	N/A	MILLING
MATERIAL	STOCK SIZE	CYLINDER STOCK SIZE	DESIGNED BY:
ALUMINUM TOOLING PLATE		\varnothing	JOSÉ FÉLIX
		L	
			DRAWN BY:
			JOSÉ FÉLIX
			APPROVED BY:
			JAVIER MOLINA
			REVIEWED BY:
			JAVIER MOLINA

REV. No.	REVISIONS	DATE	BY
			JOSÉ FÉLIX
		 <p>THIS DRAWING AND INFORMATION CONTAINED HERE ARE EXCLUSIVE PROPERTY OF KUFFERATH AND SHALL BE RETURNED UPON DEMAND AND SHALL NOT BE REPRODUCED IN WHOLE OR IN PARTS.</p>	
		<p>UNLESS OTHERWISE SPECIFIED DIMENSIONS ARE INCH OR [MM]. TOLERANCE: 0.0 = ± .1 0.00 = ± .01 0.000 = ± .001 0.0000 = ± .0005 FRACTIONAL = ± .002 ANGULAR = ± 1° ◆ CRITICAL CHARACTERISTIC</p>	

QTY

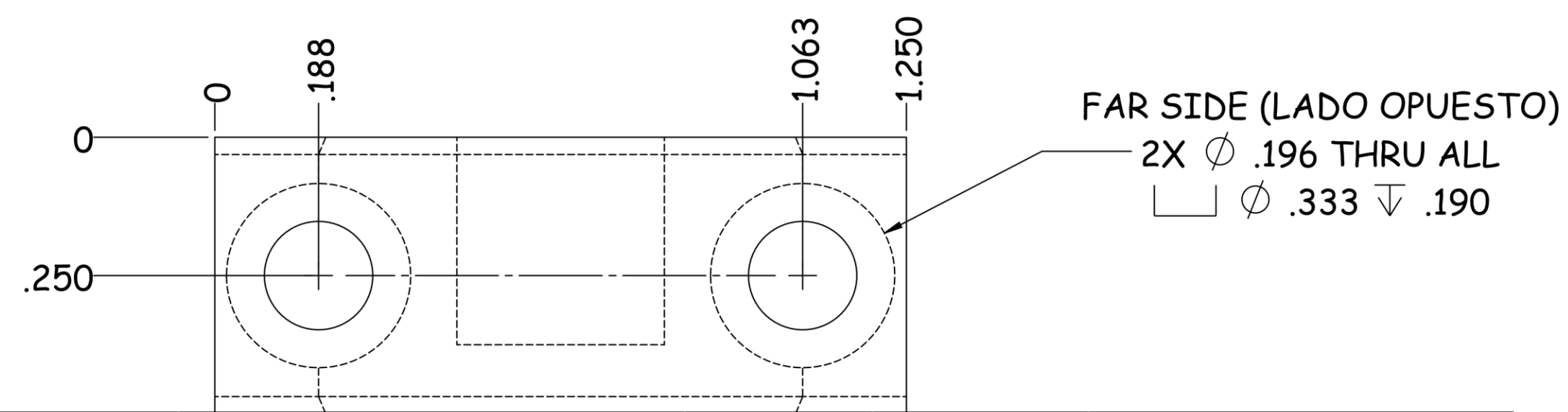
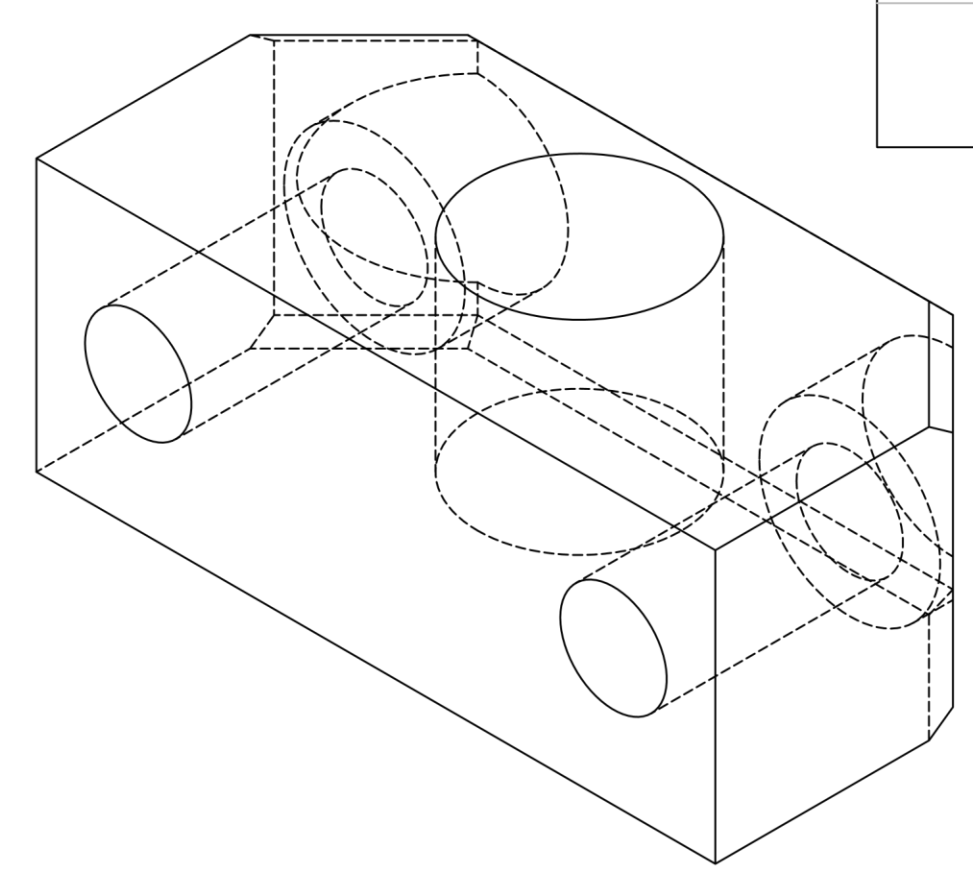
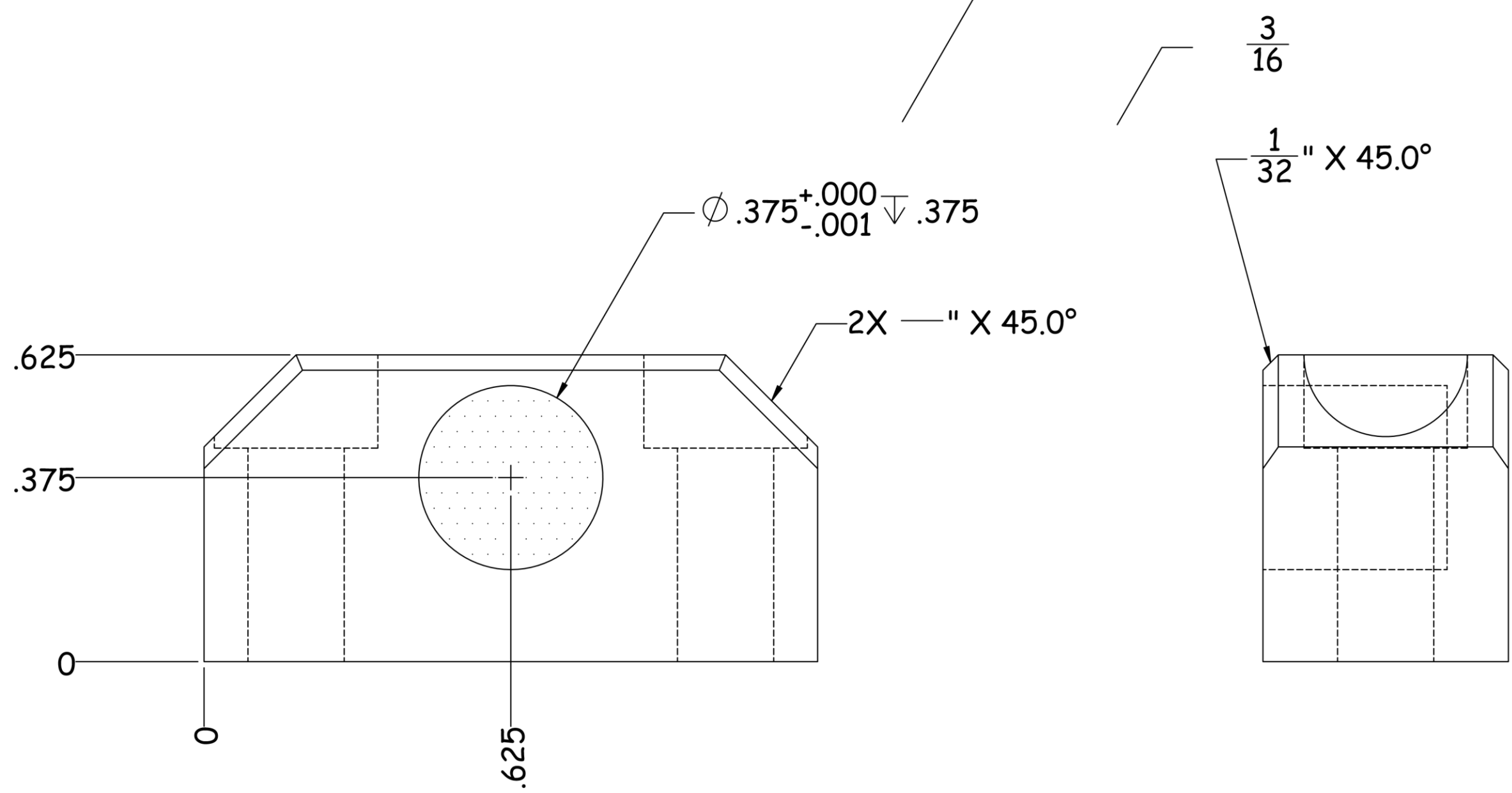

WORK TYPE		H&T		FINISH			
NEW PART		N/A		MILLING			
MATERIAL	STOCK SIZE	CYLINDER STOCK SIZE		DESIGNED BY:	DRAWN BY:	APPROVED BY:	REVIEWED BY:
ALUMINUM TOOLING PLATE		ϕ	L	JOSÉ FÉLIX	JOSÉ FÉLIX	JAVIER MOLINA	JAVIER MOLINA
		N/A	N/A				

RELEASED		011/11/2018	JOSÉ FÉLIX
REV. No.	REVISIONS	DATE	BY



THIS DRAWING AND INFORMATION CONTAINED HERE ARE EXCLUSIVE PROPERTY OF KUFFERATH AND SHALL BE RETURNED UPON DEMAND AND SHALL NOT BE REPRODUCED IN WHOLE OR IN PARTS.

UNLESS OTHERWISE SPECIFIED DIMENSIONS ARE INCH OR [MM].

TOLERANCE:

0.0 = ± .1

0.00 = ± .01

0.000 = ± .001

0.0000 = ± .0005

FRACTIONAL = ± 1/1000



ANGULAR = ± 1°

◆ CRITICAL CHARACTERISTIC

QTY

1

PROJECT		WORK TYPE		H&T		FINISH					
MR-03		NEW PART		N/A		MILLING					
MATERIAL		STOCK SIZE		DESIGNED BY:	DRAWN BY:	APPROVED BY:	REVIEWED BY:				
ALUMINUM TOOLING PLATE			<table border="1"> <tr> <td>Ø</td> <td>L</td> </tr> <tr> <td>N/A</td> <td>N/A</td> </tr> </table>	Ø	L	N/A	N/A	JOSÉ FÉLIX	JOSÉ FÉLIX	JAVIER MOLINA	JAVIER MOLINA
Ø	L										
N/A	N/A										



	RELEASED		JOSÉ FÉLIX
REV. No.	REVISIONS	DATE	BY
		 <p>THIS DRAWING AND INFORMATION CONTAINED HERE ARE EXCLUSIVE PROPERTY OF KUFFERATH AND SHALL BE RETURNED UPON DEMAND AND SHALL NOT BE REPRODUCED IN WHOLE OR IN PARTS.</p>	
		<p>UNLESS OTHERWISE SPECIFIED DIMENSIONS ARE INCH OR [MM]. TOLERANCE: 0.0 = ± .1 0.00 = ± .01 0.000 = ± .001 0.0000 = ± .0005 FRACTIONAL = ± .002 ANGULAR = ± 1° ◆ CRITICAL CHARACTERISTIC</p>	

DESCRIPTION PART NUMBER SOPORTE PARA BUJE MR-02-003

QTY

1

PROJECT	WORK TYPE	H&T	FINISH
MR-03	NEW PART	N/A	MILLING
MATERIAL	STOCK SIZE	CYLINDER STOCK SIZE	DESIGNED BY:
ALUMINUM TOOLING PLATE	1/2" 5/8" 1 1/4"	Ø	JOSÉ FÉLIX
		L	
		N/A	N/A
			DRAWN BY:
			JOSÉ FÉLIX
			APPROVED BY:
			JAVIER MOLINA
			REVIEWED BY:
			JAVIER MOLINA

REV. No.	REVISIONS	RELEASED	DATE	BY
				JOSÉ FÉLIX
		 THIRD ANGLE PROJECTION	<small>THIS DRAWING AND INFORMATION CONTAINED HERE ARE EXCLUSIVE PROPERTY OF KUFFERATH AND SHALL BE RETURNED UPON DEMAND AND SHALL NOT BE REPRODUCED IN WHOLE OR IN PARTS.</small>	
			<small>UNLESS OTHERWISE SPECIFIED DIMENSIONS ARE INCH OR [MM].</small> <small>TOLERANCE:</small> <small>0.0 = ± .1</small> <small>0.00 = ± .01</small> <small>0.000 = ± .001</small> <small>0.0000 = ± .0005</small> <small>FRACTIONAL = ± .002</small> <small>ANGULAR = ± 1°</small> <small>◆ CRITICAL CHARACTERISTIC</small>	
				

QTY

PROJECT		WORK TYPE		H&T			
MR-03		NEW PART		N/A			
		STOCK SIZE	CYLINDER STOCK SIZE	DESIGNED BY:	DRAWN BY:	APPROVED BY:	REVIEWED BY:
				JOSÉ FÉLIX	JOSÉ FÉLIX	JAVIER MOLINA	JAVIER MOLINA

	RELEASED	011/11/2018	JOSÉ FÉLIX
REV. No.	REVISIONS	DATE	BY

THIS DRAWING AND INFORMATION CONTAINED HERE ARE EXCLUSIVE PROPERTY OF KUFFERATH AND SHALL BE RETURNED UPON DEMAND AND SHALL NOT BE REPRODUCED IN WHOLE OR IN PARTS.

UNLESS OTHERWISE SPECIFIED DIMENSIONS ARE INCH OR [MM].
 TOLERANCE:
 0.0 = ± .1
 0.00 = ± .01
 0.000 = ± .001
 0.0000 = ± .0005
 FRACTIONAL = ± .002
 ANGULAR = ± 1°
 ◆ CRITICAL CHARACTERISTIC

QTY
1

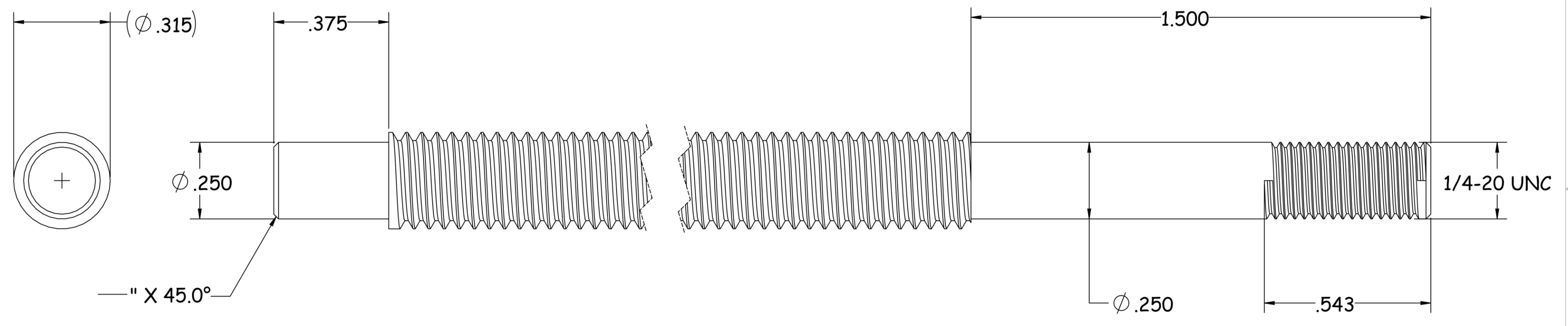
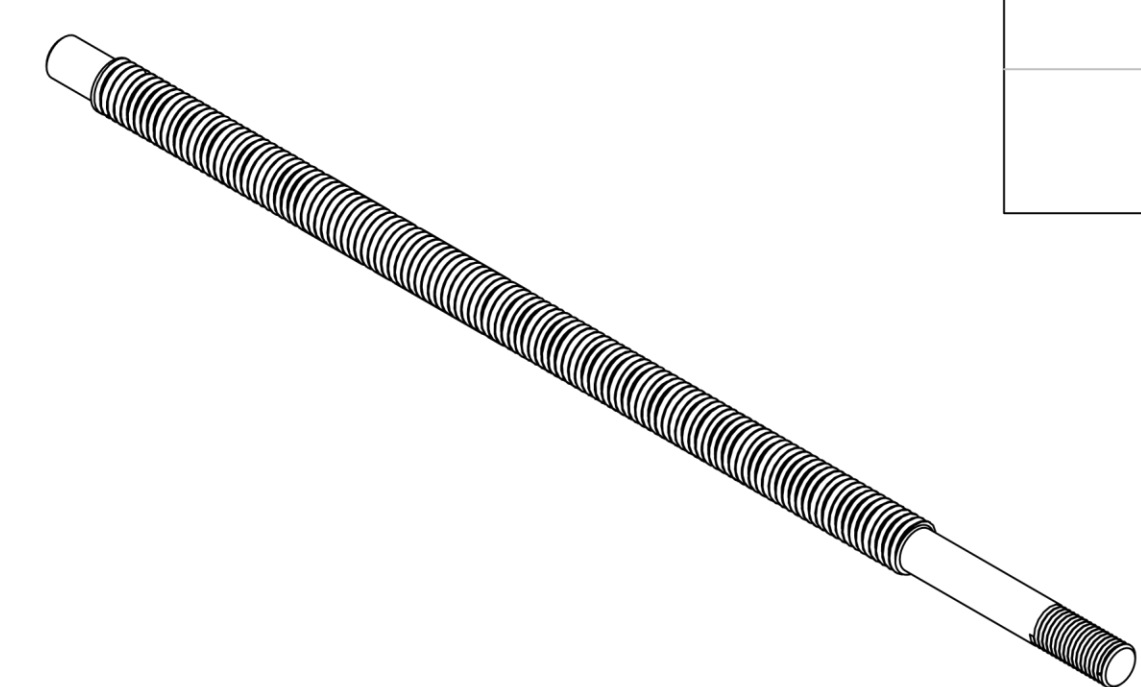

PROJECT				H&T			
MR-03				N/A			
MATERIAL		STOCK SIZE		DESIGNED BY:	DRAWN BY:	APPROVED BY:	REVIEWED BY:
				JOSÉ FÉLIX	JOSÉ FÉLIX	JAVIER MOLINA	JAVIER MOLINA
6	5	7	CYLINDER	4	6	3	5

RELEASED 011/11/2018 JOSÉ FÉLIX

REV. No.	REVISIONS	DATE	BY
2			

UNLESS OTHERWISE SPECIFIED DIMENSIONS ARE INCH OR [MM].

0.00 = ± .01
0.000 = ± .001
0.0000 = ± .0005

FRACTIONAL = ± .002
ANGULAR = ± 1°

◆ CRITICAL CHARACTERISTIC

THIRD ANGLE

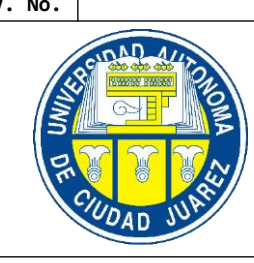

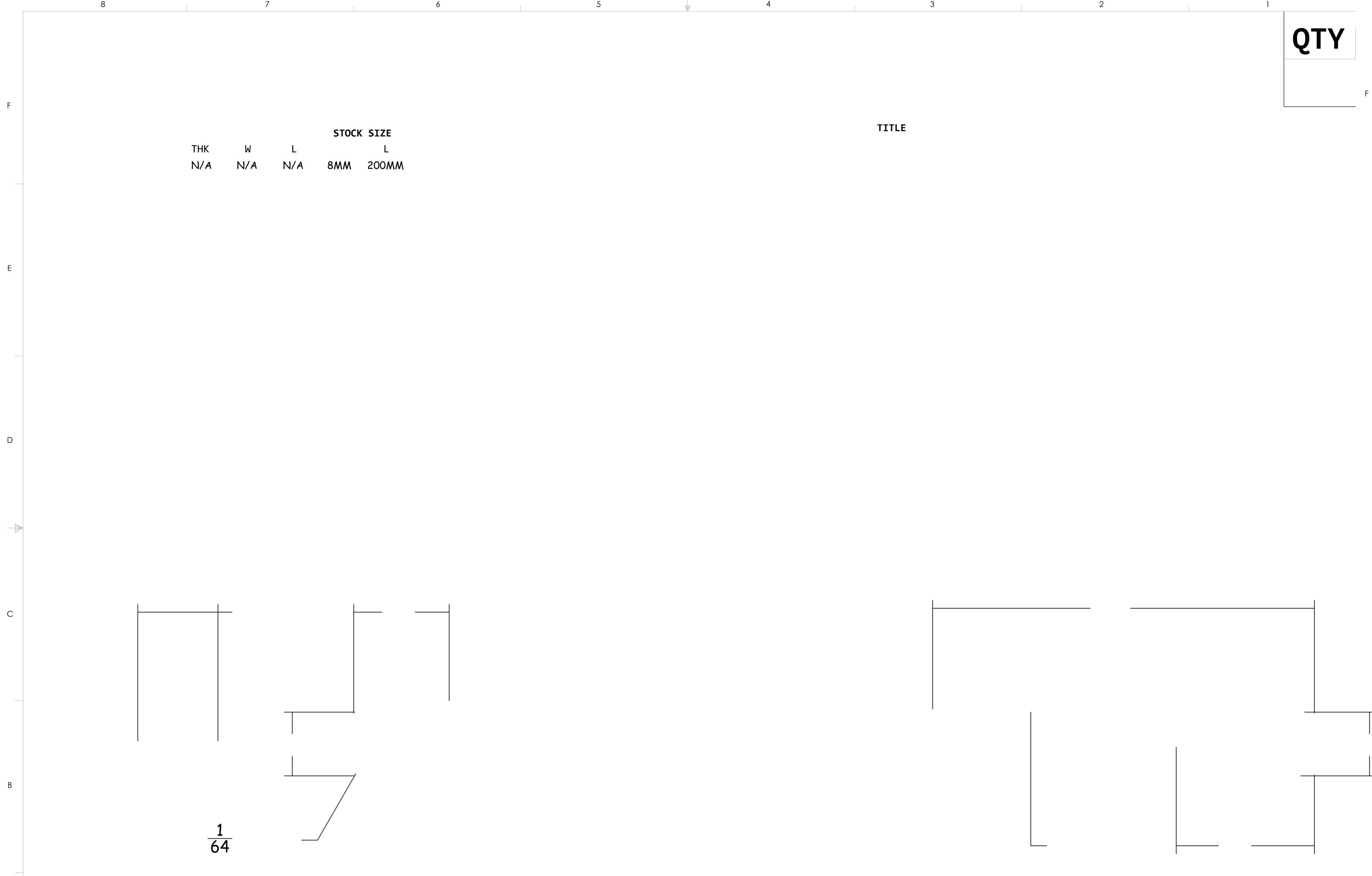

STOCK SIZE
 THK W L
 N/A N/A N/A 8MM 200MM

TITLE

QTY

PROJECT					H&T			
MR-03					N/A			
STOCK SIZE		CYLINDER STOCK SIZE		DESIGNED BY:	DRAWN BY:	APPROVED BY:	REVIEWED BY:	
				JOSÉ FÉLIX	JOSÉ FÉLIX	JAVIER MOLINA	JAVIER MOLINA	
		N/A	L N/A					

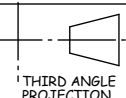
REV. No.		REVISIONS		DATE	BY
				011/11/2018	JOSÉ FÉLIX
 KUFFERATH Testing Technology GROUP		 THIRD ANGLE PROJECTION		THIS DRAWING AND INFORMATION CONTAINED HERE ARE EXCLUSIVE PROPERTY OF KUFFERATH AND SHALL BE RETURNED UPON DEMAND AND SHALL NOT BE REPRODUCED IN WHOLE OR IN PARTS.	
		UNLESS OTHERWISE SPECIFIED DIMENSIONS ARE INCH OR [MM]. TOLERANCE: 0.0 = ± .1 0.00 = ± .01 0.000 = ± .001 0.0000 = ± .0005 FRACTIONAL = ± .002 ANGULAR = ± 1 ♦ CRITICAL CHARACTERISTIC			

QTY

1

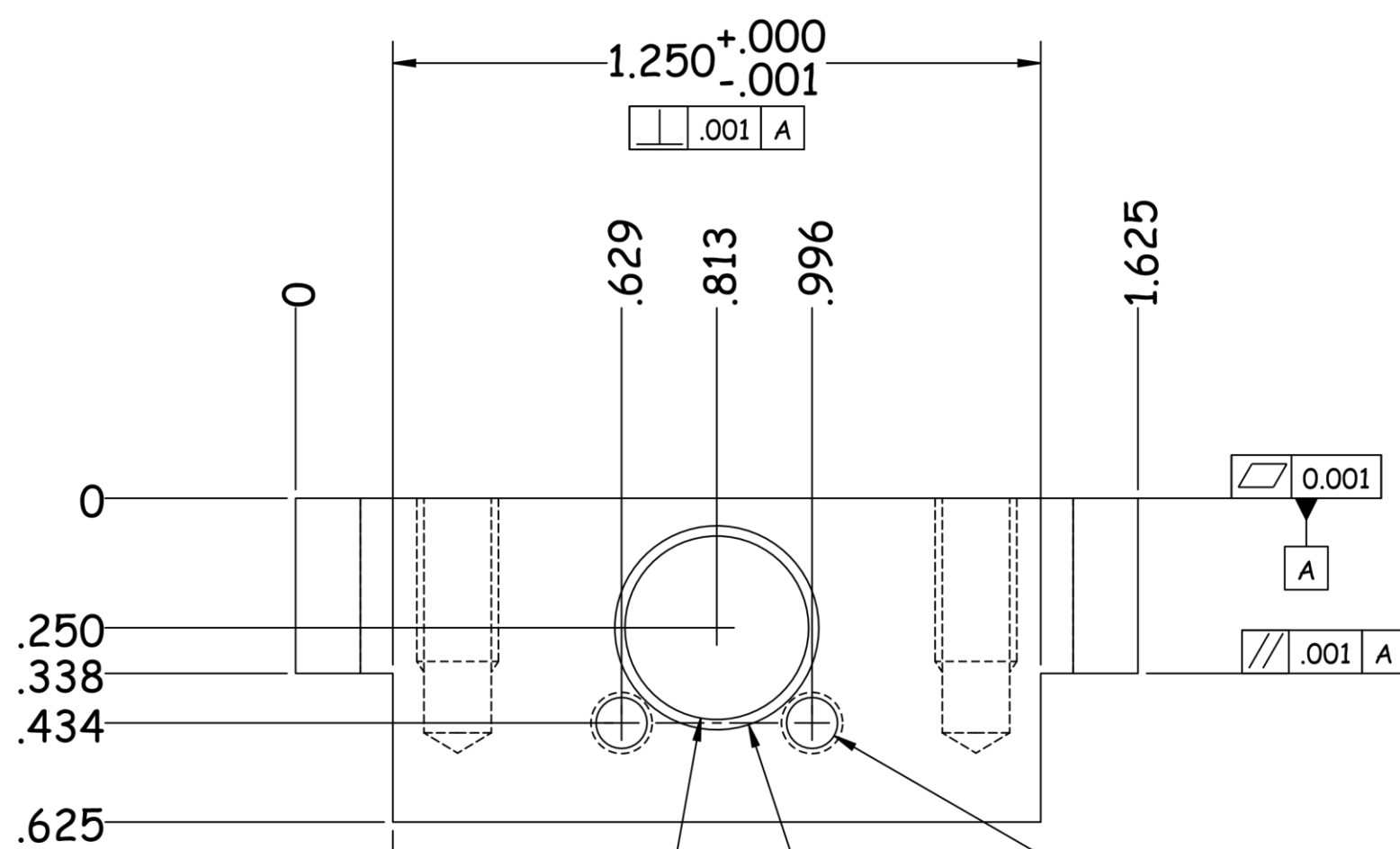
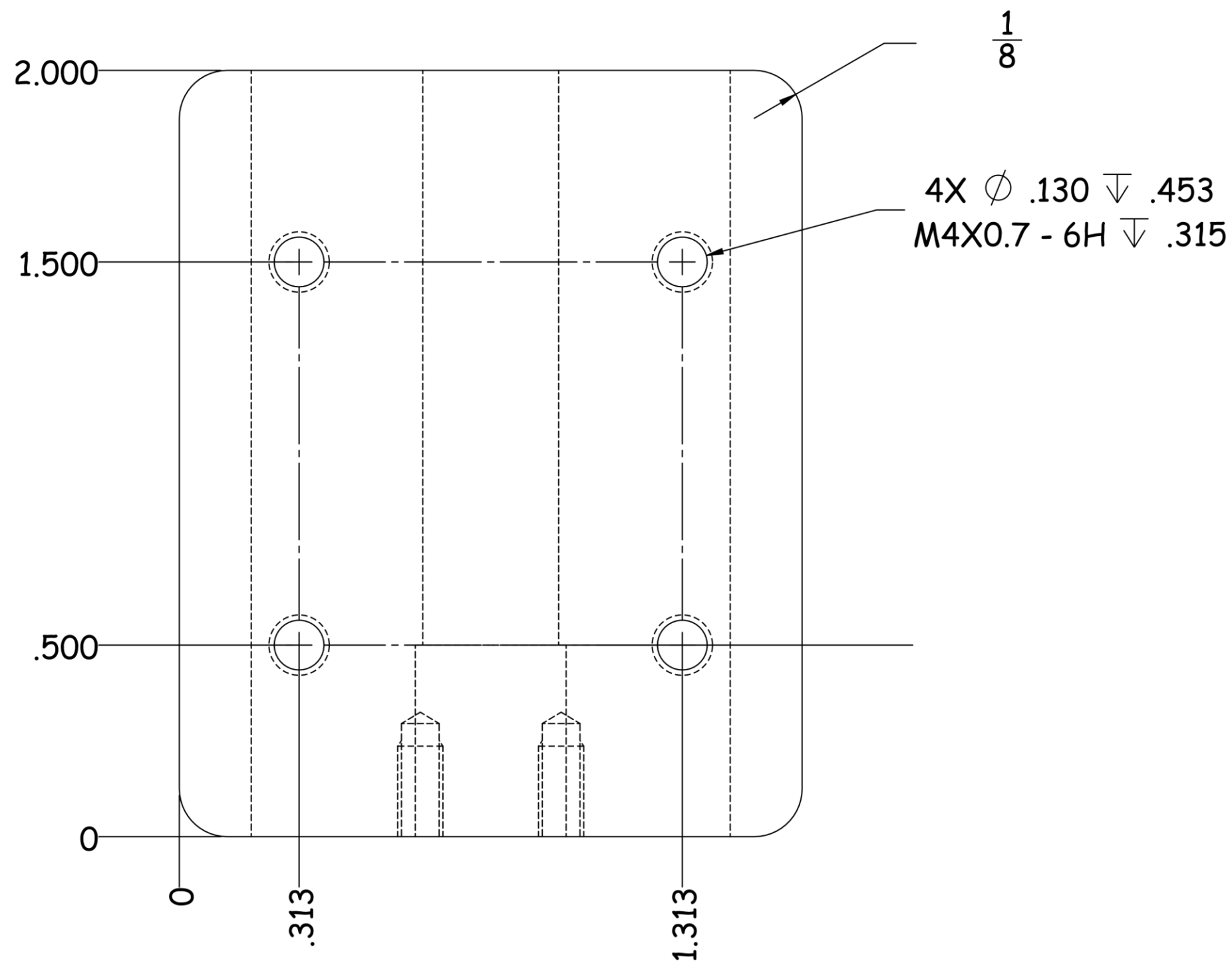

PROJECT	MR-03	H&T	N/A	DESIGNED BY:	JOSÉ FÉLIX	DRAWN BY:	JOSÉ FÉLIX	APPROVED BY:	JAVIER MOLINA	REVIEWED BY:	JAVIER MOLINA
MATERIAL		STOCK SIZE									

REV. No.		REVISIONS		DATE	BY
2		1		01/11/2018	JOSÉ FÉLIX
					
<p>UNLESS OTHERWISE SPECIFIED DIMENSIONS ARE INCH OR [MM].</p> <p>0.00 = ± .01 0.000 = ± .001 0.0000 = ± .0005</p> <p>FRACTIONAL = ± .002 ANGULAR = ± 1 ◆ CRITICAL CHARACTERISTIC</p>					

QTY
1

.500(A)

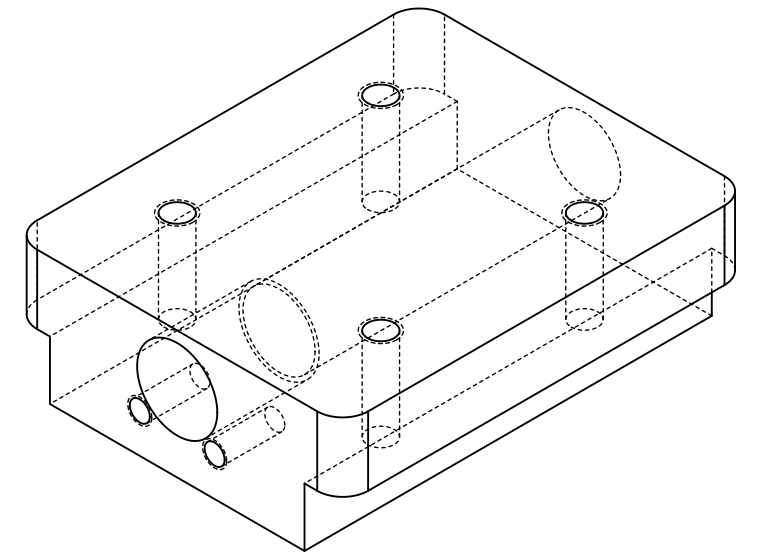

FINISH
MILLING

TITLE

PROJECT				H&T				
MR-03				N/A				
	STOCK SIZE		CYLINDER STOCK SIZE		DESIGNED BY:	DRAWN BY:	APPROVED BY:	REVIEWED BY:
			N/A	L N/A	JOSÉ FÉLIX	JOSÉ FÉLIX	JAVIER MOLINA	JAVIER MOLINA

0	RELEASED	011/11/2018	JOSÉ FÉLIX
REV. No.	REVISIONS	DATE	BY



KUFFERATH
Testing Technology GROUP



THIS DRAWING AND INFORMATION CONTAINED HERE ARE EXCLUSIVE PROPERTY OF KUFFERATH AND SHALL BE RETURNED UPON DEMAND AND SHALL NOT BE REPRODUCED IN WHOLE OR IN PARTS.

THIRD ANGLE PROJECTION

UNLESS OTHERWISE SPECIFIED DIMENSIONS ARE INCH OR [MM].
TOLERANCE:
 0.0 = ± .1
 0.00 = ± .01
 0.000 = ± .001
 0.0000 = ± .0005
 FRACTIONAL = ± .002
 ANGULAR = ± 1
 ♦ CRITICAL CHARACTERISTIC

QTY

1

RELEASED		011/11/2018	JOSÉ FÉLIX
REV. No.	REVISIONS	DATE	BY
		 THIRD ANGLE PROJECTION	<small>THIS DRAWING AND INFORMATION CONTAINED HERE ARE EXCLUSIVE PROPERTY OF KUFFERATH AND SHALL BE RETURNED UPON DEMAND AND SHALL NOT BE REPRODUCED IN WHOLE OR IN PARTS.</small>
			

WORK TYPE		H&T					
NEW PART		N/A					
PROJECT	MATERIAL DESCRIPTION	STOCK SIZE	PART NUMBER	DESIGNED BY:	DRAWN BY: TREATMENT	APPROVED BY: FINISH	REVIEWED BY:
			L N/A	JOSÉ FÉLIX	JOSÉ FÉLIX	JAVIER MOLINA	JAVIER MOLINA

F MR-02 BRACKET PARA PALPADOR

MR-02-007
CYLINDER
STOCK SIZE

N/A

MILLING

				H&T			
				N/A			
		STOCK SIZE		DESIGNED BY:		DRAWN BY:	
		CYLINDER STOCK SIZE		JOSÉ FÉLIX		JOSÉ FÉLIX	
		N/A				APPROVED BY:	
		L				JAVIER MOLINA	
		N/A				REVIEWED BY:	
						JAVIER MOLINA	

011/10/2018 JOSÉ FÉLIX

DATE	BY

THIS DRAWING AND INFORMATION CONTAINED HERE ARE EXCLUSIVE PROPERTY OF KEPPERATH AND SHALL BE RETURNED UPON DEMAND AND SHALL NOT BE REPRODUCED IN WHOLE OR IN PARTS.

UNLESS OTHERWISE SPECIFIED DIMENSIONS ARE INCH OR [MM].
 TOLERANCE:
 0.0 = ± .1
 0.00 = ± .01
 0.000 = ± .001
 0.0000 = ± .0005
 FRACTIONAL = ± .002
 ANGULAR = ± 1
 ◆ CRITICAL CHARACTERISTIC

6 5 7 4 6 3 5 2 4 1 3 2 1

QTY

1

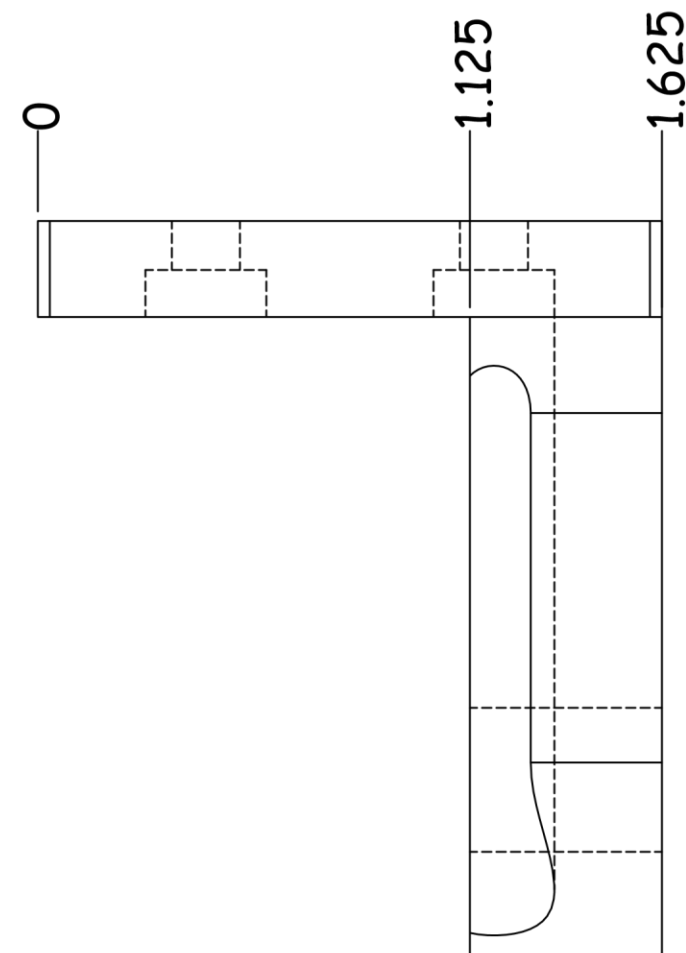
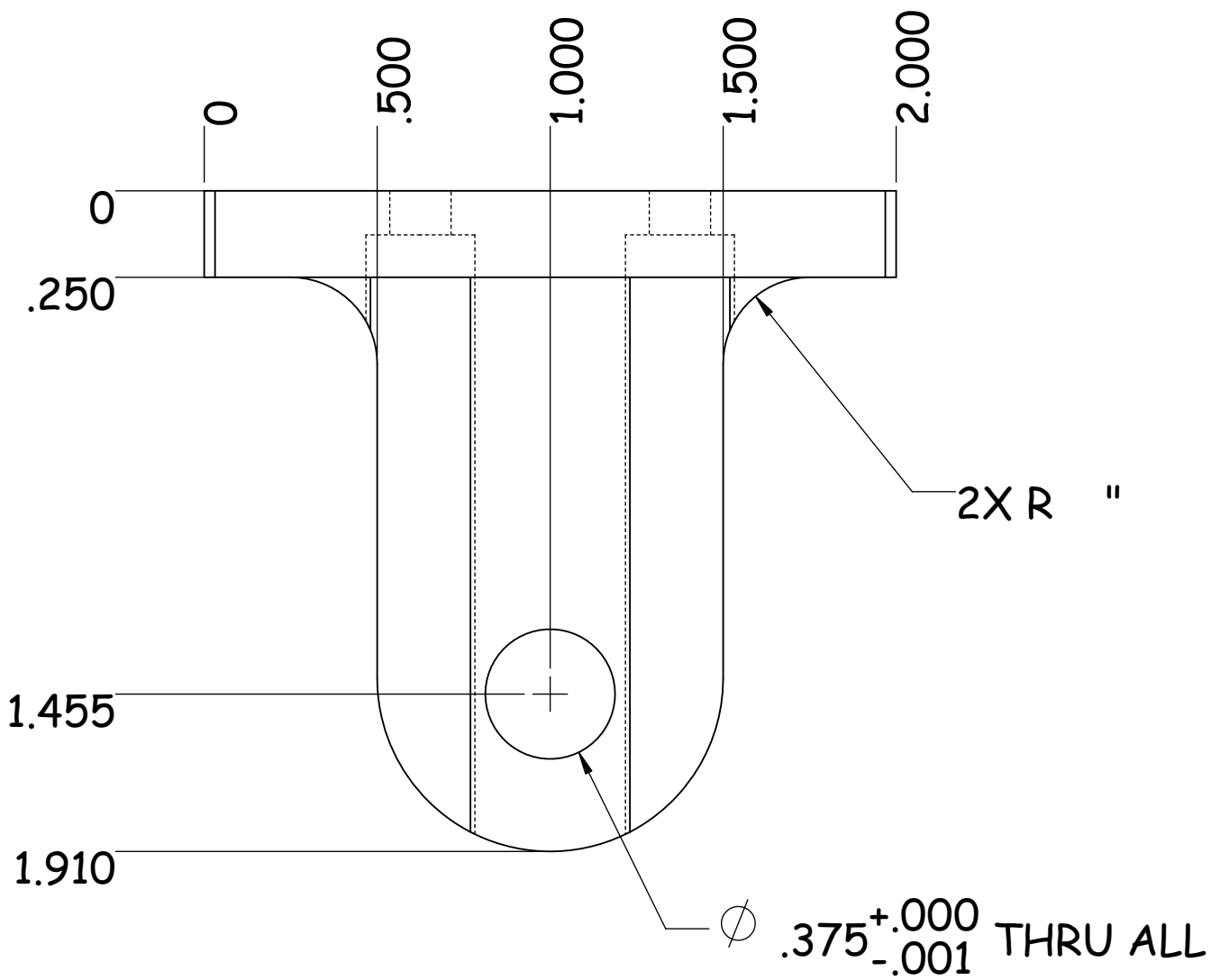
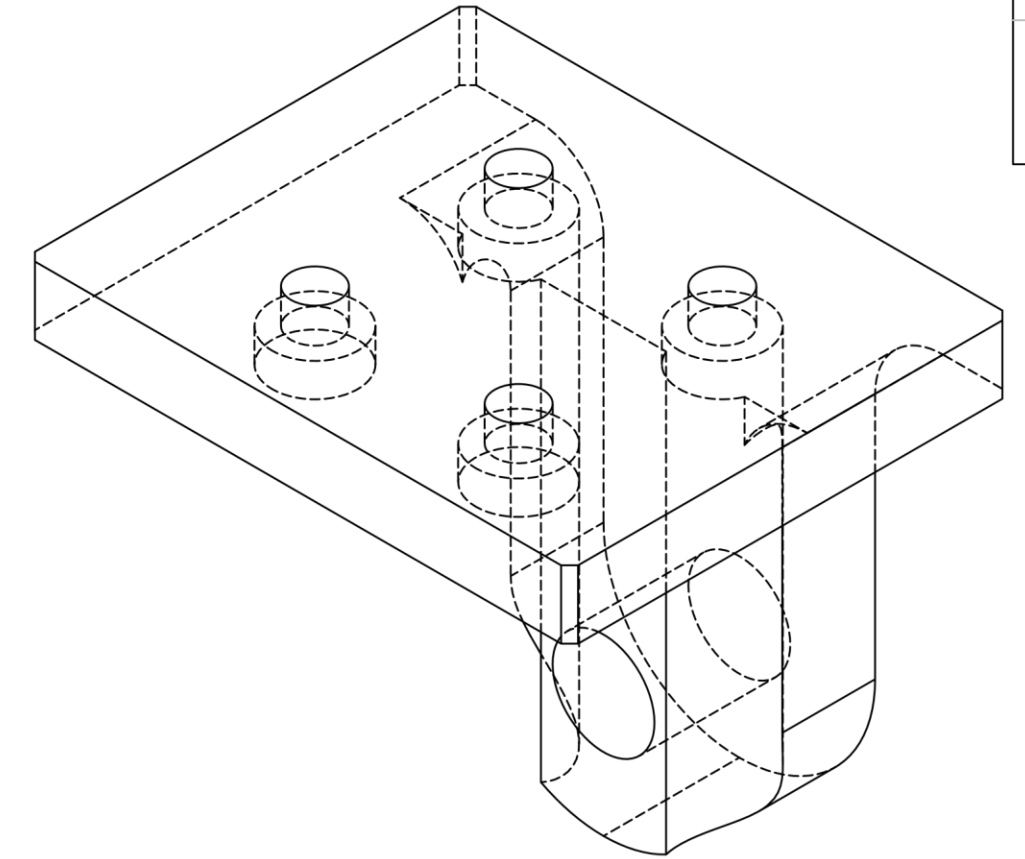

REV. No.	REVISIONS	DATE	BY
2			JOSÉ FÉLIX
1			

UNLESS OTHERWISE SPECIFIED DIMENSIONS ARE INCH OR [MM].
 TOLERANCE:
 0.0 = ±.1
 0.00 = ±.01
 0.000 = ±.001
 0.0000 = ±.0005
 FRACTIONAL = ±.002
 ANGULAR = ± 1°
 ◆ CRITICAL CHARACTERISTIC

WORK TYPE	H&T	DESIGNED BY:	DRAWN BY:	APPROVED BY:	REVIEWED BY:
NEW PART	N/A	JOSÉ FÉLIX	JOSÉ FÉLIX	JAVIER MOLINA	JAVIER MOLINA
STOCK SIZE					
1.625					

" X 45.0°

	THK	W	L	Ø
ABS	1 5/8"	2"	2"	N/A

STOCK SIZE		CYLINDER STOCK SIZE		DESIGNED BY:	DRAWN BY:	APPROVED BY:	REVIEWED BY:
			L				
		N/A	N/A	JOSÉ FÉLIX	JOSÉ FÉLIX	JAVIER MOLINA	JAVIER MOLINA

H&T
N/A

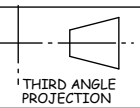

THIS DRAWING AND INFORMATION CONTAINED HERE ARE EXCLUSIVE PROPERTY OF KEPPERATH AND SHALL BE RETURNED UPON DEMAND AND SHALL NOT BE REPRODUCED IN WHOLE OR IN PARTS.

UNLESS OTHERWISE SPECIFIED DIMENSIONS ARE INCH OR [MM].
 TOLERANCE:
 0.0 = ± .1
 0.00 = ± .01
 0.000 = ± .001
 0.0000 = ± .0005
 FRACTIONAL = ± .002
 ANGULAR = ± 1
 ◆ CRITICAL CHARACTERISTIC

011/10/2018 JOSÉ FÉLIX



DATE	BY

QTY
1

F

		WORK TYPE		H&T			
		NEW PART		N/A			
		STOCK SIZE		DESIGNED BY:	DRAWN BY:	APPROVED BY:	REVIEWED BY:
8	7		6	JOSÉ FÉLIX	5	JAVIER MOLINA	JAVIER MOLINA
6	5	7	4	6	3	5	2
							1

10

REV. No.		REVISIONS		DATE	BY
				<small>THIS DRAWING AND INFORMATION CONTAINED HERE ARE EXCLUSIVE PROPERTY OF KUFFERATH AND SHALL BE RETURNED UPON DEMAND AND SHALL NOT BE REPRODUCED IN WHOLE OR IN PARTS.</small>	
		<small>UNLESS OTHERWISE SPECIFIED DIMENSIONS ARE INCH OR [MM].</small>		<small>TOLERANCE:</small> <small>0.0 = ± .1</small> <small>0.00 = ± .01</small> <small>0.000 = ± .001</small> <small>0.0000 = ± .0005</small> <small>FRACTIONAL = ± .002</small> <small>ANGULAR = ± 1</small> <small>◆ CRITICAL CHARACTERISTIC</small>	

RELEASED JOSÉ FÉLIX

A

F

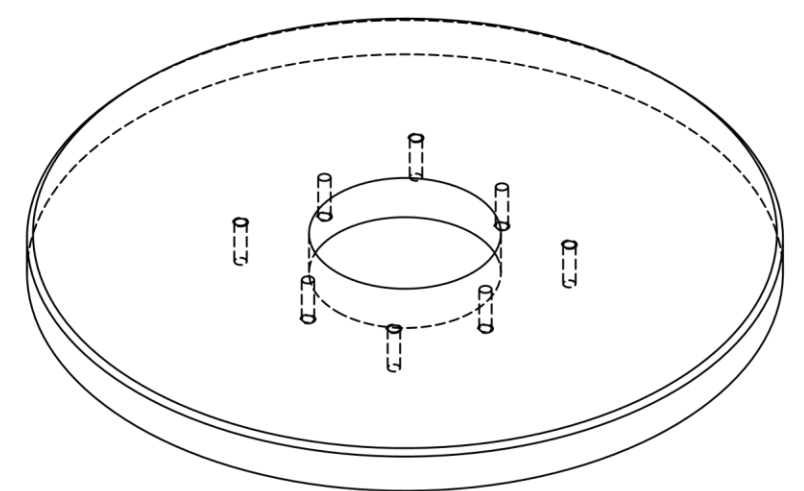
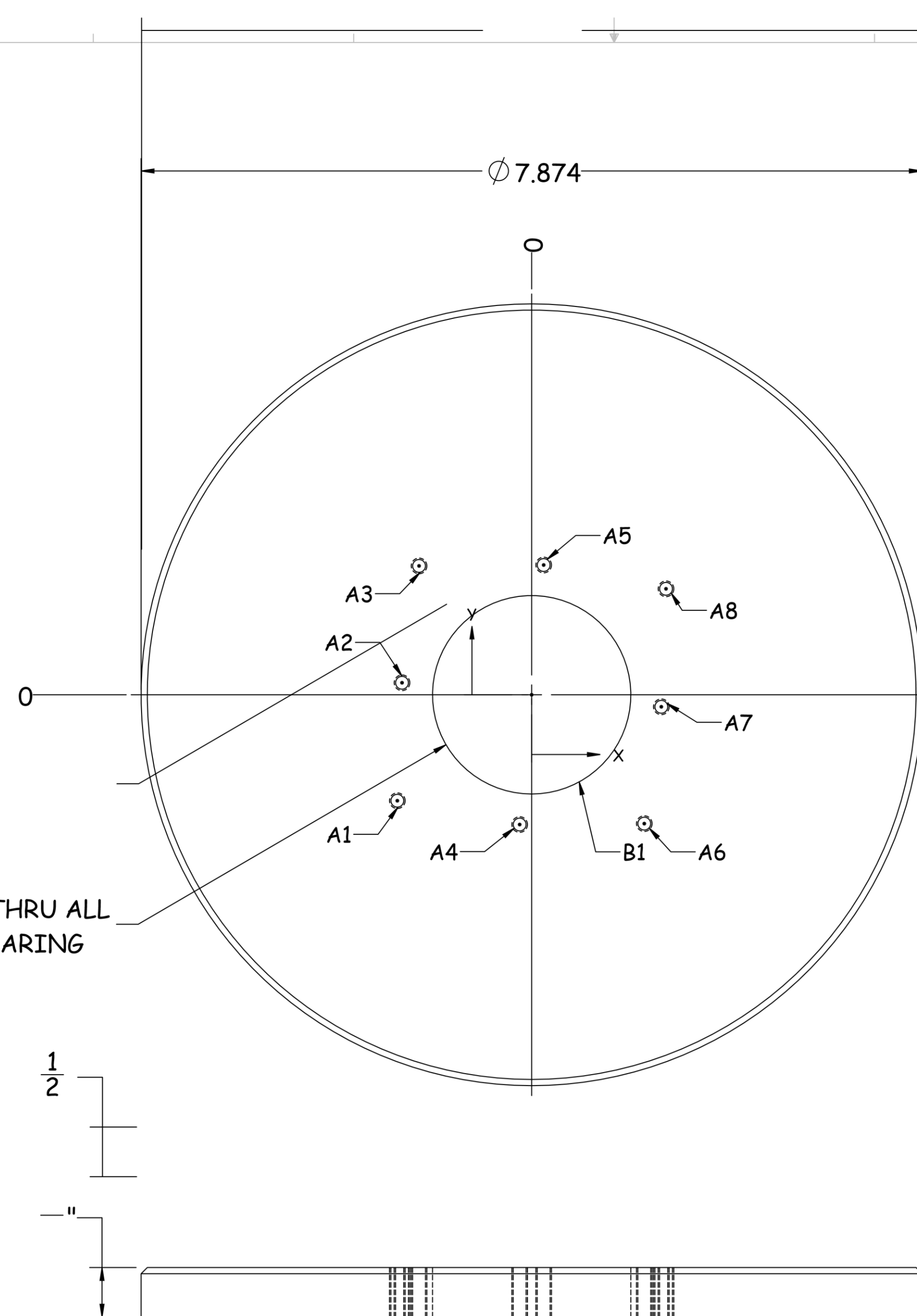

TAG	X LOC	Y LOC	SIZE
A1	-1.354	-1.067	Ø .130 THRU ALL M4X0.7 - 6H THRU ALL
A2	-1.307	.121	
A3	-1.135	1.298	
A4	-.121	-1.307	
A5	.121	1.307	
A6	1.135	-1.298	
A7	1.307	-.121	
A8	1.354	1.067	
B1	.000	.000	Ø 1.999 THRU ALL

				H&T			
				N/A			
		STOCK SIZE		DESIGNED BY:		DRAWN BY:	
		CYLINDER STOCK SIZE		JOSÉ FÉLIX		TREATMENT	
PROJECT		PART NUMBER		JOSÉ FÉLIX		JAVIER MOLINA	
		N/A N/A				APPROVED BY:	
						JAVIER MOLINA	
						REVIEWED BY:	
						JAVIER MOLINA	

011/10/2018 JOSÉ FÉLIX

DATE	BY
011/10/2018	JOSÉ FÉLIX

THIS DRAWING AND INFORMATION CONTAINED HERE ARE EXCLUSIVE PROPERTY OF KEPPERATH AND SHALL BE RETURNED UPON DEMAND AND SHALL NOT BE REPRODUCED IN WHOLE OR IN PARTS.

UNLESS OTHERWISE SPECIFIED DIMENSIONS ARE INCH OR [MM].

TOLERANCE:

0.0 = ± .1

0.00 = ± .01

0.000 = ± .001

0.0000 = ± .0005

FRACTIONAL = ± .002

ANGULAR = ± 1

CRITICAL CHARACTERISTIC

E

D

C

B

A



QTY
1

MR-01 BASE DE CHUCK MR-03-001
CYLINDER **ANODIZED**

MATERIAL

MATERIAL	THK	W	L	STOCK SIZE	
				Ø	L
ALUMINUM TOOLING PLATE	N/A	N/A	N/A	7 7/8"	1/2"



		WORK TYPE		H&T			
		NEW PART		N/A			
		STOCK SIZE		DESIGNED BY:	DRAWN BY:	APPROVED BY:	REVIEWED BY:
				JOSÉ FÉLIX	JOSÉ FÉLIX	JAVIER MOLINA	JAVIER MOLINA

REV. No.		REVISIONS		DATE	BY
				<small>THIS DRAWING AND INFORMATION CONTAINED HERE ARE EXCLUSIVE PROPERTY OF KUFFERATH AND SHALL BE RETURNED UPON DEMAND AND SHALL NOT BE REPRODUCED IN WHOLE OR IN PARTS.</small>	
		<small>UNLESS OTHERWISE SPECIFIED DIMENSIONS ARE INCH OR [MM].</small> TOLERANCE: 0.0 = ± .1 0.00 = ± .01 0.000 = ± .001 0.0000 = ± .0005 FRACTIONAL = ± .002 ANGULAR = ± 1 ♦ CRITICAL CHARACTERISTIC			

QTY

1

		WORK TYPE		H&T			
		NEW PART		N/A			
		STOCK SIZE	CYLINDER STOCK SIZE	DESIGNED BY:	DRAWN BY:	APPROVED BY:	REVIEWED BY:
			∅	JOSÉ FÉLIX	JOSÉ FÉLIX	JAVIER MOLINA	JAVIER MOLINA
			N/A				
PROJECT	DESCRIPTION	W	L	PART NUMBER	TREATMENT	FINISH	TITLE MR-

	RELEASED	011/10/2018	JOSÉ FÉLIX
REV. No.	REVISIONS	DATE	BY
		 <small>THIS DRAWING AND INFORMATION CONTAINED HERE ARE EXCLUSIVE PROPERTY OF KUFFERATH AND SHALL BE RETURNED UPON DEMAND AND SHALL NOT BE REPRODUCED IN WHOLE OR IN PARTS.</small>	
		<small>UNLESS OTHERWISE SPECIFIED DIMENSIONS ARE INCH OR [MM].</small> <small>TOLERANCE:</small> <small>0.0 = ± .1</small> <small>0.00 = ± .01</small> <small>0.000 = ± .001</small> <small>0.0000 = ± .0005</small> <small>FRACTIONAL = ± .002</small> <small>ANGULAR = ± 1°</small> <small>◆ CRITICAL CHARACTERISTIC</small>	
			

QTY

1



MR-03 BASE PARA CHUCK 3" 3" MR-03-002 ANODIZED MILLING 03-002

MATERIAL

ALUMINUM TOOLING PLATE THK L

3/4 N/A

		WORK TYPE		H&T			
		NEW PART		N/A			
		STOCK SIZE	CYLINDER STOCK SIZE	DESIGNED BY:	DRAWN BY:	APPROVED BY:	REVIEWED BY:
			∅	JOSÉ FÉLIX	JOSÉ FÉLIX	JAVIER MOLINA	JAVIER MOLINA
			N/A				

	RELEASED	01/10/2018	JOSÉ FÉLIX
REV. No.	REVISIONS	DATE	BY
		 <small>THIS DRAWING AND INFORMATION CONTAINED HERE ARE EXCLUSIVE PROPERTY OF KUFFERATH AND SHALL BE RETURNED UPON DEMAND AND SHALL NOT BE REPRODUCED IN WHOLE OR IN PARTS.</small>	
		<small>UNLESS OTHERWISE SPECIFIED DIMENSIONS ARE INCH OR [MM].</small> <small>TOLERANCE:</small> <small>0.0 = ± .1</small> <small>0.00 = ± .01</small> <small>0.000 = ± .001</small> <small>0.0000 = ± .0005</small> <small>FRACTIONAL = ± .002</small> <small>ANGULAR = ± 1°</small> <small>◆ CRITICAL CHARACTERISTIC</small>	
			

QTY

1

Ø

4X Ø .177 THRU ALL
□ Ø .315 ▽ .157

.760 THRU ALL

3.000

2.688

1.500

H&T
N/A

DESIGNED BY:

DRAWN BY:

APPROVED BY:

REVIEWED BY:

JOSÉ FÉLIX

JOSÉ FÉLIX

JAVIER MOLINA

JAVIER MOLINA

STOCK SIZE

CYLINDER
STOCK SIZE

Ø

N/A

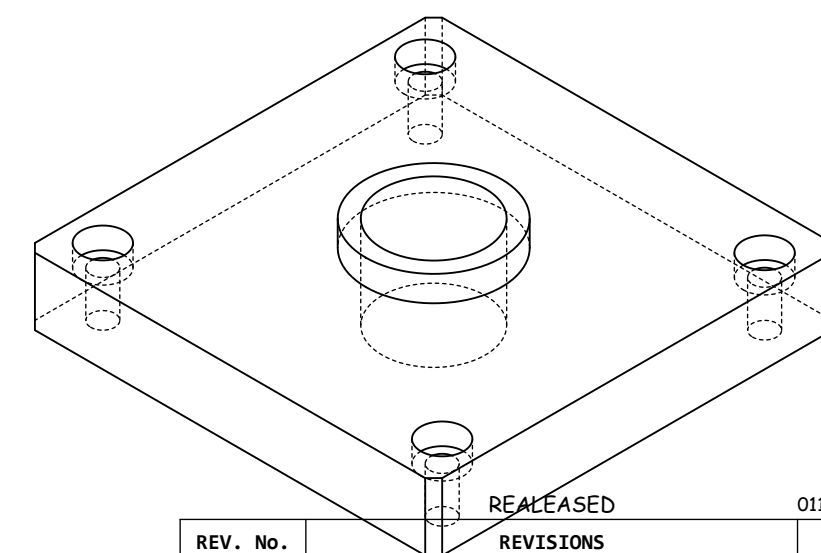

RELEASED

011/10/2018 JOSÉ FÉLIX

REV. No.

REVISIONS

DATE

BY

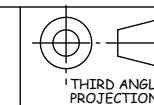
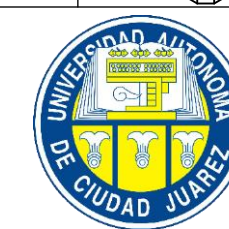

THIS DRAWING AND INFORMATION
CONTAINED HERE ARE EXCLUSIVE
PROPERTY OF KUFFERATH AND SHALL BE
RETURNED UPON DEMAND AND SHALL
NOT BE REPRODUCED IN WHOLE OR IN
PARTS.

KUFFERATH
Testing Technology GROUP

UNLESS OTHERWISE SPECIFIED
DIMENSIONS ARE INCH OR [MM].
TOLERANCE:
0.0 = ± .1
0.00 = ± .01
0.000 = ± .001
0.0000 = ± .0005
FRACTIONAL = ± .002
ANGULAR = ± 1
◆ CRITICAL CHARACTERISTIC

1.000

1 3

2

1

6

5 7

4

6

3 5

↑

2

4

QTY
1

$\frac{1}{16}$

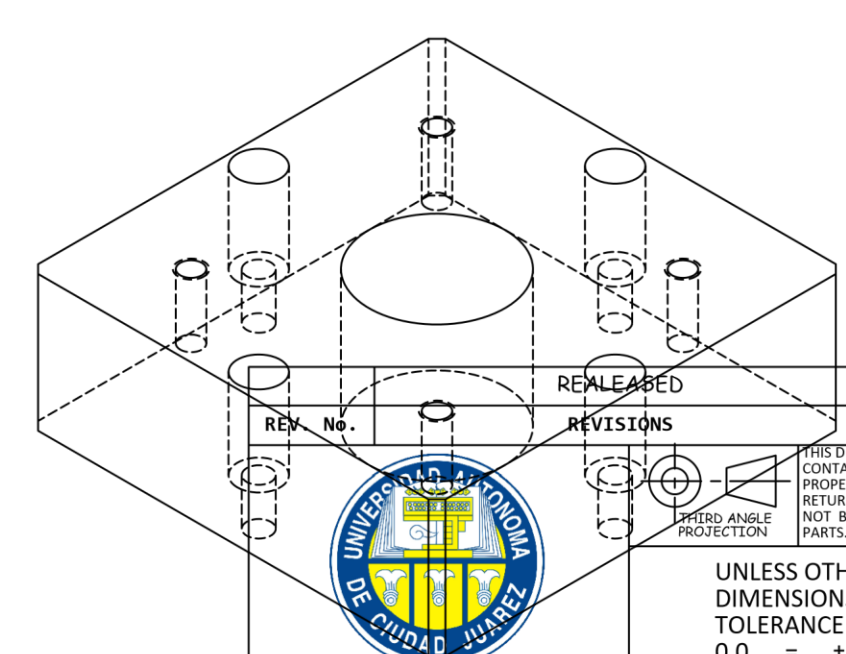
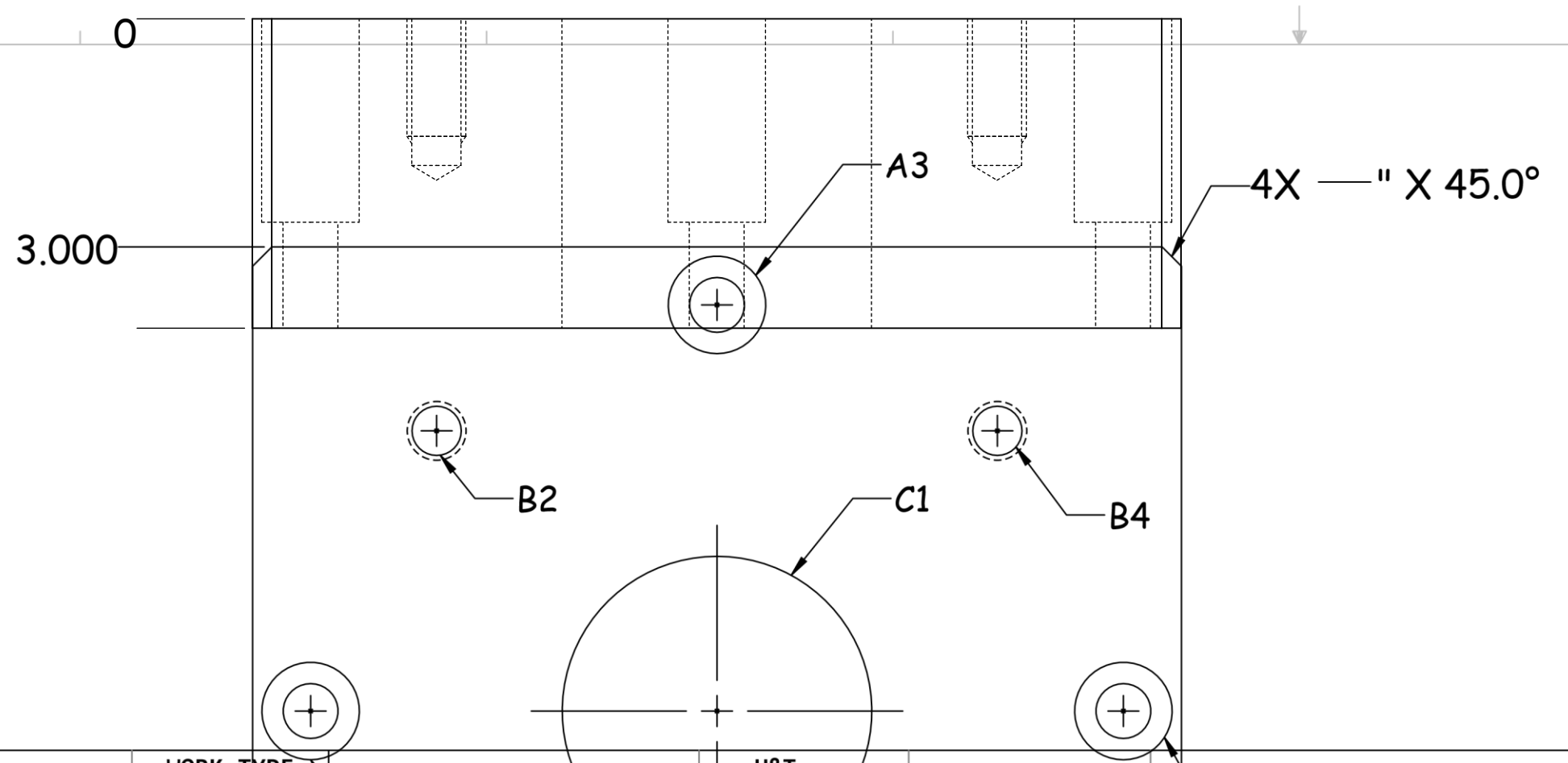

WORK TYPE		H&T		DESIGNED BY:		DRAWN BY:		APPROVED BY:		REVIEWED BY:	
NEW PART		N/A		JOSÉ FÉLIX		JOSÉ FÉLIX		JAVIER MOLINA		JAVIER MOLINA	
STOCK SIZE		CYLINDER STOCK SIZE		DATE		REV. No.		REVISIONS		DATE	
1.000		N/A		01/10/2018		1		RELEASED		JOSÉ FÉLIX	

UNLESS OTHERWISE SPECIFIED DIMENSIONS ARE INCH OR [MM].
 TOLERANCE:
 0.0 = ± .1
 0.00 = ± .01
 0.000 = ± .001
 0.0000 = ± .0005
 FRACTIONAL = ± .002
 ANGULAR = ± 1°
 ◆ CRITICAL CHARACTERISTIC

THIS DRAWING AND INFORMATION CONTAINED HERE ARE EXCLUSIVE PROPERTY OF KUFFERATH AND SHALL BE RETURNED UPON DEMAND AND SHALL NOT BE REPRODUCED IN WHOLE OR IN PARTS.

THIRD ANGLE PROJECTION



KUFFERATH
Testing Technology GROUP

QTY
1

F

PROJECT	DESCRIPTION	PART NUMBER	TREATMENT
MR-03	ESPACIADOR PARA STEPPER	MR-03-003	ANODIZED BLACK
MATERIAL			
ALUMINUM 6061	THK W L	L	
	1" 3" 3"	N/A	



DESIGNED BY:		DRAWN BY:		APPROVED BY:		REVIEWED BY:	
H&T N/A		JOSÉ FÉLIX		JAVIER MOLINA		JAVIER MOLINA	
STOCK SIZE		CYLINDER STOCK SIZE					
		Ø					
		N/A					

REV. No.		REVISIONS		DATE	BY
011/10/2018		JOSÉ FÉLIX			
				<small>THIS DRAWING AND INFORMATION CONTAINED HERE ARE EXCLUSIVE PROPERTY OF KUFFERATH AND SHALL BE RETURNED UPON DEMAND AND SHALL NOT BE REPRODUCED IN WHOLE OR IN PARTS.</small>	
		<small>UNLESS OTHERWISE SPECIFIED DIMENSIONS ARE INCH OR [MM].</small>		<small>TOLERANCE:</small> 0.0 = ±.1 0.00 = ±.01 0.000 = ±.001 0.0000 = ±.0005 FRACTIONAL = ±.002 ANGULAR = ± 1 ♦ CRITICAL CHARACTERISTIC	

QTY

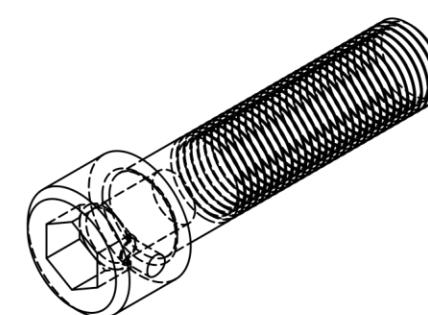
1



REV. No.		RELEASED	01/10/2018	JOSÉ FÉLIX
REVISIONS		DATE	BY	
		 THIRD ANGLE PROJECTION	<small>THIS DRAWING AND INFORMATION CONTAINED HERE ARE EXCLUSIVE PROPERTY OF KUFFERATH AND SHALL BE RETURNED UPON DEMAND AND SHALL NOT BE REPRODUCED IN WHOLE OR IN PARTS.</small>	
			<small>UNLESS OTHERWISE SPECIFIED DIMENSIONS ARE INCH OR [MM]. TOLERANCE: 0.0 = ± .1 0.00 = ± .01 0.000 = ± .001 0.0000 = ± .0005 FRACTIONAL = ± .002 ANGULAR = ± 1° ◆ CRITICAL CHARACTERISTIC</small>	
				



WORK TYPE		H&T	
NEW PART		N/A	
STOCK SIZE		CYLINDER STOCK SIZE	DESIGNED BY:
		∅	JOSÉ FÉLIX
		N/A	JOSÉ FÉLIX
			DRAWN BY:
			JOSÉ FÉLIX
			APPROVED BY:
			JAVIER MOLINA
			REVIEWED BY:
			JAVIER MOLINA

$\varnothing 315.8 \pm .012$ $\varnothing 241.4 \pm .005$ $\varnothing .750 (A)$ $\varnothing .130$ THRU ALL 2.500

QTY
1



M4X0.7 - 6H THRU ALL

				H&T			
				N/A			
		STOCK SIZE		DESIGNED BY:		DRAWN BY:	
		CYLINDER STOCK SIZE		JOSÉ FÉLIX		JOSÉ FÉLIX	
		Ø				APPROVED BY:	
		N/A				JAVIER MOLINA	
						REVIEWED BY:	
						JAVIER MOLINA	

REV. No.		REVISIONS		DATE		BY	
				011/10/2018		JOSÉ FÉLIX	
				<small>THIS DRAWING AND INFORMATION CONTAINED HERE ARE EXCLUSIVE PROPERTY OF KUFFERATH AND SHALL BE RETURNED UPON DEMAND AND SHALL NOT BE REPRODUCED IN WHOLE OR IN PARTS.</small>			
				<small>UNLESS OTHERWISE SPECIFIED DIMENSIONS ARE INCH OR [MM].</small> <small>TOLERANCE:</small> <small>0.0 = ± .1</small> <small>0.00 = ± .01</small> <small>0.000 = ± .001</small> <small>0.0000 = ± .0005</small> <small>FRACTIONAL = ± .002</small> <small>ANGULAR = ± 1</small> <small>◆ CRITICAL CHARACTERISTIC</small>			
							

QTY

1

RELEASED		01/10/2018	JOSÉ FÉLIX
REV. No.	REVISIONS	DATE	BY
		 <small>THIS DRAWING AND INFORMATION CONTAINED HERE ARE EXCLUSIVE PROPERTY OF KUFFERATH AND SHALL BE RETURNED UPON DEMAND AND SHALL NOT BE REPRODUCED IN WHOLE OR IN PARTS.</small>	
		<small>UNLESS OTHERWISE SPECIFIED DIMENSIONS ARE INCH OR [MM].</small> <small>TOLERANCE:</small> <small>0.0 = ± .1</small> <small>0.00 = ± .01</small> <small>0.000 = ± .001</small> <small>0.0000 = ± .0005</small> <small>FRACTIONAL = ± .002</small> <small>ANGULAR = ± 1°</small> <small>◆ CRITICAL CHARACTERISTIC</small>	
			

WORK TYPE		H&T					
NEW PART		N/A					
STOCK SIZE		CYLINDER STOCK SIZE	DESIGNED BY:	DRAWN BY:	APPROVED BY:	REVIEWED BY:	
		∅	JOSÉ FÉLIX	JOSÉ FÉLIX	JAVIER MOLINA	JAVIER MOLINA	
		N/A					

FINISH



QTY
1

F

LATHE

TITLE

				H&T			
				N/A			
		STOCK SIZE		CYLINDER STOCK SIZE		DESIGNED BY:	
				Ø		DRAWN BY:	
				N/A		APPROVED BY:	
				JOSÉ FÉLIX		REVIEWED BY:	
				JOSÉ FÉLIX		JAVIER MOLINA	
						JAVIER MOLINA	

REV. No.		REVISIONS		DATE		BY	
				011/10/2018		JOSÉ FÉLIX	
				<small>THIS DRAWING AND INFORMATION CONTAINED HERE ARE EXCLUSIVE PROPERTY OF KUFFERATH AND SHALL BE RETURNED UPON DEMAND AND SHALL NOT BE REPRODUCED IN WHOLE OR IN PARTS.</small>			
				<small>UNLESS OTHERWISE SPECIFIED DIMENSIONS ARE INCH OR [MM].</small> <small>TOLERANCE:</small> <small>0.0 = ± .1</small> <small>0.00 = ± .01</small> <small>0.000 = ± .001</small> <small>0.0000 = ± .0005</small> <small>FRACTIONAL = ± .002</small> <small>ANGULAR = ± 1</small> <small>◆ CRITICAL CHARACTERISTIC</small>			
